

THE UNIVERSITY OF THE STATE OF NEW YORK

GRADE 8

INTERMEDIATE-LEVEL SCIENCE TEST

WRITTEN TEST

JUNE 6, 2011

Student Name _____

School Name _____

Print your name and the name of your school on the lines above.

The questions on this test measure your knowledge and understanding of science. The test has two parts. Both parts are contained in this test booklet.

Part I consists of 45 multiple-choice questions. Record your answers to these questions on the separate answer sheet. Use only a No. 2 pencil on your answer sheet.

Part II consists of 38 open-ended questions. Write your answers to these questions in the spaces provided in this test booklet.

You may use a calculator to answer the questions on the test if needed.

You will have two hours to answer the questions on this test.

DO NOT TURN THIS PAGE UNTIL YOU ARE TOLD TO DO SO.

Copyright 2011

THE UNIVERSITY OF THE STATE OF NEW YORK
THE STATE EDUCATION DEPARTMENT
ALBANY, NEW YORK 12234

Part I

DIRECTIONS

There are 45 questions on Part I of the test. Each question is followed by three or four choices, numbered 1 through 4. Read each question carefully. Decide which choice is the best answer. On the separate answer sheet, mark your answer in the row of circles for each question by filling in the circle that has the same number as the answer you have chosen.

Read the sample question below.

Sample Question

Earth gets most of its light from

- (1) the stars
- (2) the Sun
- (3) the Moon
- (4) other planets

The correct answer is **the Sun**, which is choice number **2**. On your answer sheet, look at the box showing the row of answer circles for the sample question. Since choice number **2** is the correct answer for the sample question, the circle with the number **2** has been filled in.

Answer all of the questions in Part I in the same way. Mark only one answer for each question. If you want to change an answer, be sure to erase your first mark completely. Then mark the answer you want.

You will not need scrap paper. You may use the pages of this test booklet to work out your answers to the questions.

You may use a calculator if needed.

When you are told to start working, turn the page and begin with question 1. Work carefully and answer all of the questions in Part I.

When you have finished Part I, go right on to Part II. Answer all of the questions in Part II.

Part I

- 1 The diagram below shows water in a graduated cylinder.

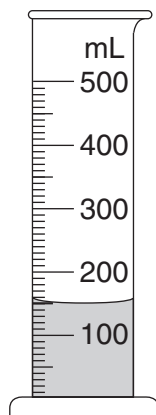

A student states that the graduated cylinder contains 150 mL of water. This statement is

- (1) a prediction (3) a theory
 (2) an observation (4) a hypothesis
- 2 The average daily air temperature at a certain location increases when there is a seasonal increase in the number of daylight hours. Which graph best shows this change?

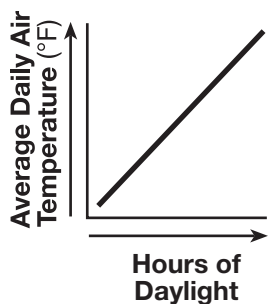

(1)

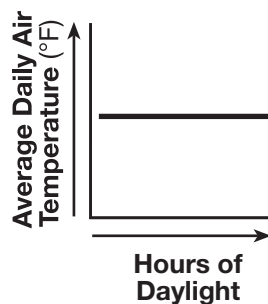

(3)

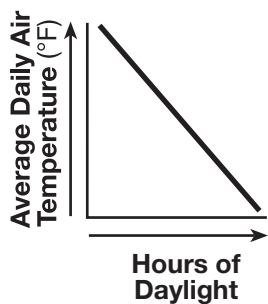

(2)

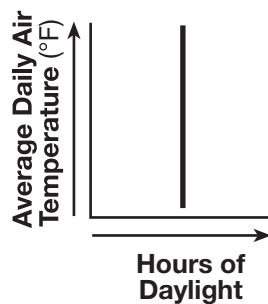

(4)

Note that question 3 has only three choices.

- 3 The data table below shows that as the pressure of a gas sample was changed, the volume of the gas changed. The pressure was measured in atmospheres (atm) and the volume was measured in milliliters (mL).

Pressure and Volume of a Gas Sample

Pressure (atm)	Volume (mL)
1.0	120.0
2.0	60.0
4.0	30.0
8.0	15.0

According to the data table, as the pressure of the gas increases, the volume of the gas

- (1) decreases
 (2) increases
 (3) remains the same
- 4 Which type of energy in gasoline is transformed into mechanical energy in a motorcycle engine?
 (1) chemical (3) magnetic
 (2) nuclear (4) electrical
- 5 A Punnett square is shown below. The dominant trait is represented by *R*. The recessive trait is represented by *r*.

	<i>R</i>	<i>r</i>
<i>R</i>	<i>RR</i>	<i>Rr</i>
<i>r</i>	<i>Rr</i>	<i>rr</i>

What percentage of the offspring will most likely show the dominant trait?

- (1) 25% (3) 75%
 (2) 50% (4) 100%

Base your answers to questions 6 and 7 on the graph below and on your knowledge of science. The graph shows the average monthly air temperatures for three different locations, A, B, and C.

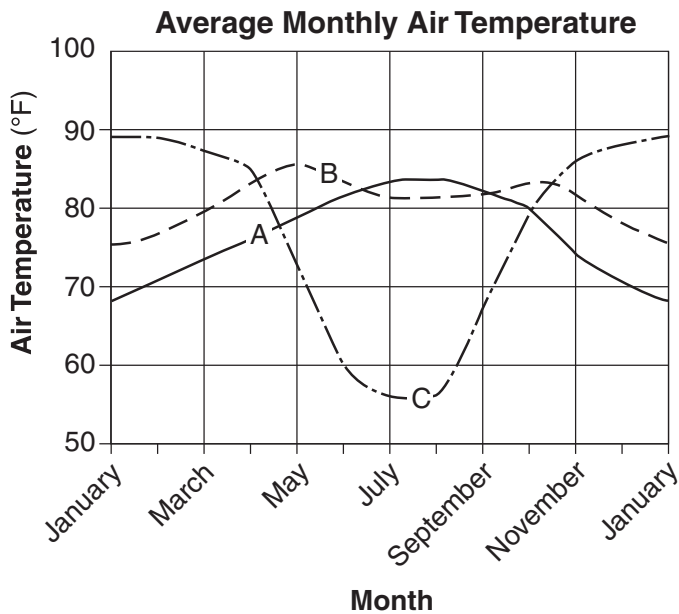

Note that question 6 has only three choices.

6 Which location experiences the *least* change in average monthly air temperature between its warmest and coldest months?

- (1) A
- (2) B
- (3) C

7 Where is location C most likely located?

- (1) Southern Hemisphere
- (2) New York State
- (3) equator
- (4) North Pole

8 Which term identifies a single unit of hereditary information?

- (1) egg cell
- (2) sperm cell
- (3) nucleus
- (4) gene

9 The sum of all chemical reactions in the human body is known as

- (1) feedback
- (2) metabolism
- (3) dynamic equilibrium
- (4) biological adaptation

10 The main function of hormones in the human body is to

- (1) identify and destroy microbes
- (2) regulate body functions
- (3) transport blood to cells
- (4) store energy

11 Which human organ system produces sperm or egg cells?

- (1) digestive system
- (2) nervous system
- (3) respiratory system
- (4) reproductive system

12 Naturally occurring variations within a species are mainly the result of mutations and

- (1) sexual reproduction
- (2) dynamic equilibrium
- (3) metabolism
- (4) camouflage

13 Animals may fight, make threatening sounds, and act aggressively toward members of the same species. These behaviors usually occur as the result of

- (1) competition
- (2) conservation
- (3) decomposition
- (4) pollution

14 During which process does a caterpillar become a butterfly?

- (1) fertilization
- (2) metamorphosis
- (3) asexual reproduction
- (4) biological adaptation

15 The diagram below shows views of the same onion cells observed by a student under a compound light microscope before and after a laboratory procedure.

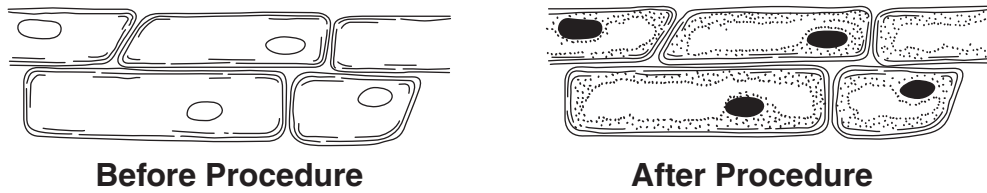

What did the student most likely do to cause the difference between the two views?

- (1) increased the magnification
- (2) decreased the magnification
- (3) added stain to the cells
- (4) added water to the cells

16 The hydra shown below is reproducing asexually.

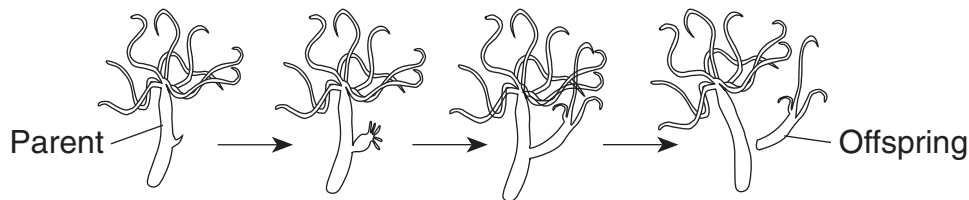

What percentage of the offspring's genetic information is the same as the genetic information of the parent?

- (1) 25%
- (2) 50%
- (3) 75%
- (4) 100%

17 The diagram below shows a food chain.

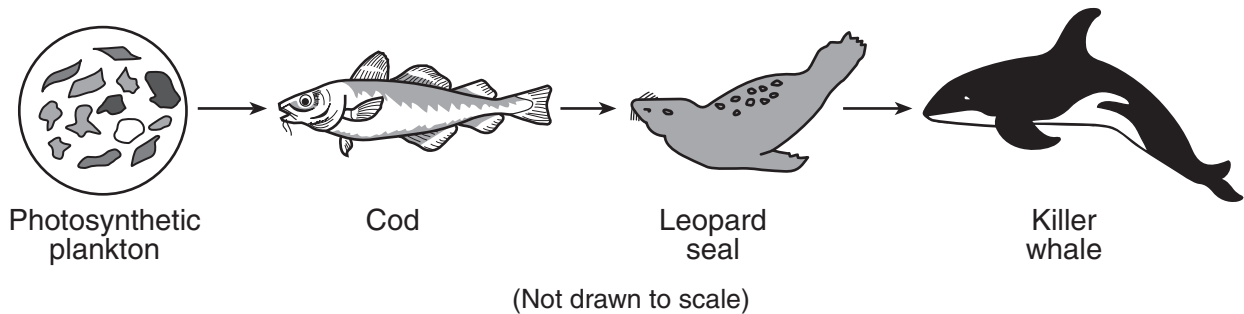

What do the arrows in the diagram represent?

- (1) flow of energy
- (2) life cycle stages
- (3) one community replacing another
- (4) renewable resource depletion

Base your answers to questions 18 and 19 on the diagram below and on your knowledge of science. The diagram shows how modern types of flowers developed from early types of flowers over the last 75 million years.

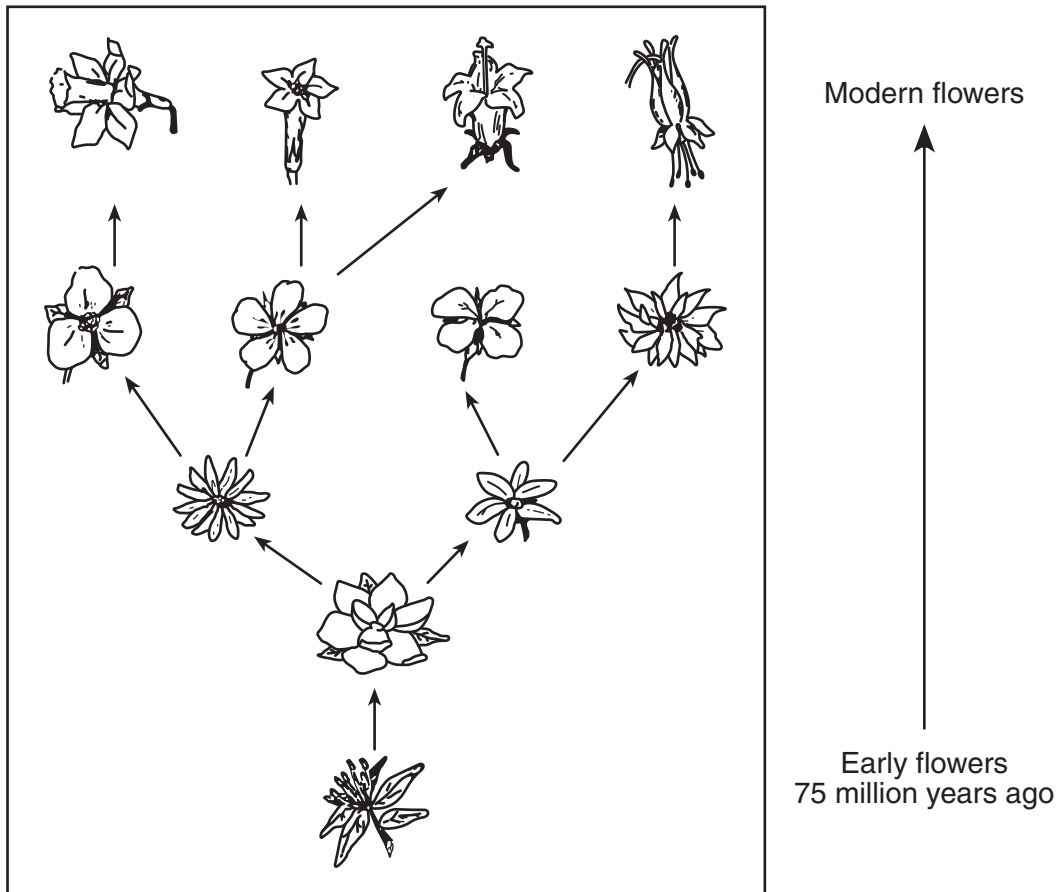

18 What is the most likely reason why these early flowers gradually changed to many different types of flowers over time?

- (1) The flowers' traits were genetically engineered.
- (2) The environments of the flowers stayed the same.
- (3) The genetic material of the flowers stayed the same.
- (4) The flowers adapted to environmental conditions.

19 Which process is represented in this diagram?

- (1) evolution
- (2) photosynthesis
- (3) selective breeding
- (4) ecological succession

20 Which sequence represents the order of development for many plants?

- (1) seed develops inside fruit → seed is dispersed → seed germinates → plant grows
- (2) seed is dispersed → seed develops inside fruit → seed germinates → plant grows
- (3) seed germinates → plant grows → seed is dispersed → seed develops inside fruit
- (4) seed is dispersed → plant grows → seed germinates → seed develops inside fruit

- 21 Cancer is best described as
- (1) a type of genetic engineering
 - (2) the merging of sex cells
 - (3) abnormal cell division
 - (4) tissue that stops growing
- 22 A cat jumps when startled by a loud noise. This is an example of an organism
- (1) sensing and responding to its external environment
 - (2) sensing and responding to its internal environment
 - (3) changing and controlling its external environment
 - (4) changing and controlling its internal environment
- 23 The diagram below shows a life process taking place within a cell.

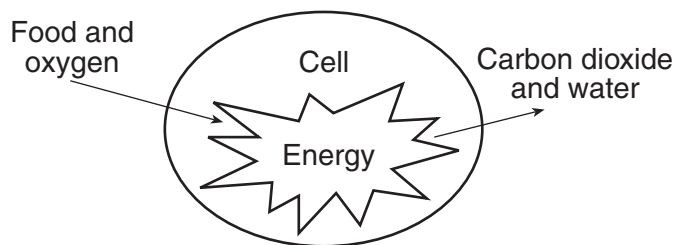

Which life process is shown?

- (1) reproduction
 - (2) digestion
 - (3) respiration
 - (4) locomotion
- 24 Which outcome is most likely if a person consumes more Calories than needed for daily activities?
- (1) weight loss
 - (2) weight gain
 - (3) deficiency disease
 - (4) infectious disease

- 25 Organisms that consume wastes to obtain the nutrients they need to survive are classified as
- (1) decomposers
 - (2) herbivores
 - (3) predators
 - (4) producers
- 26 Which term identifies a group of cells that work together to perform a similar function?
- (1) molecule
 - (2) organ
 - (3) organism
 - (4) tissue
- 27 Pesticides and fertilizers can help farmers to produce more crops. However, overuse of these chemicals can result in
- (1) ecological succession
 - (2) material recycling
 - (3) environmental pollution
 - (4) selective breeding
- 28 Which force keeps the planets in their orbits around the Sun?
- (1) gravity
 - (2) magnetism
 - (3) electricity
 - (4) friction
- 29 Which material is primarily a mixture of weathered rock and organic matter?
- (1) minerals
 - (2) soil
 - (3) ocean water
 - (4) seashells
- 30 Most of Earth's major earthquakes are caused by
- (1) seasonal heating and cooling of Earth's surface
 - (2) weathering of rock at Earth's surface
 - (3) Earth's gravitational attraction to the Moon
 - (4) faulting of rock in Earth's crust

Base your answers to questions 31 and 32 on the diagram below and on your knowledge of science. The diagram represents the motion of the Moon around Earth as seen from above the North Pole. One position of the Moon in its orbit is shown.

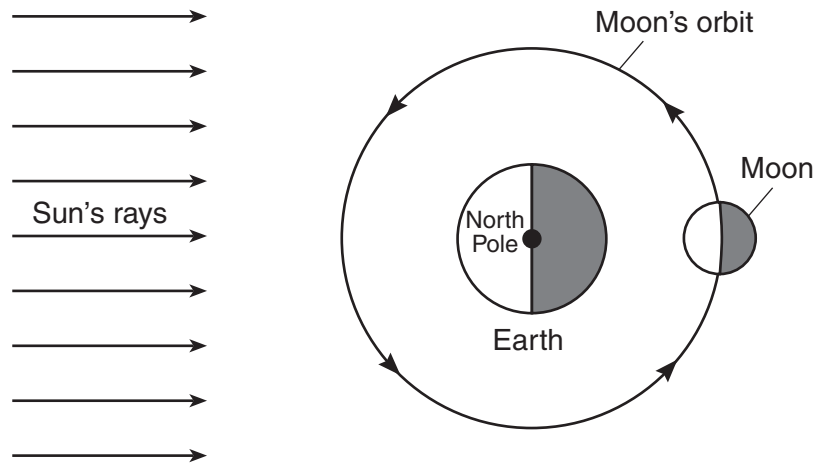

(Not drawn to scale)

31 Which Moon phase will usually be seen from Earth when the Moon is in this position?

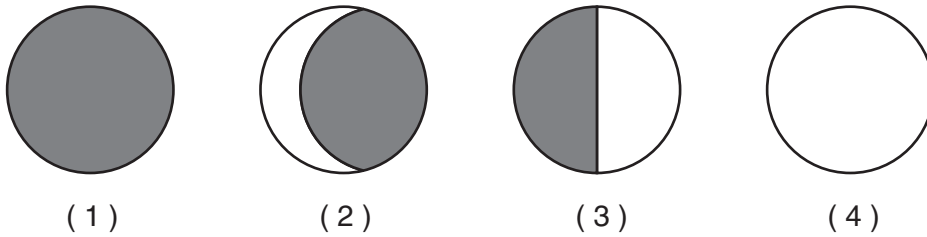

32 The time it takes the Moon to revolve once around Earth is approximately one

- (1) day
- (2) week
- (3) month
- (4) year

33 The diagram below shows two locations where fossils of *Mesosaurus* have been found. *Mesosaurus* was a freshwater reptile that existed on Earth about 250 million years ago.

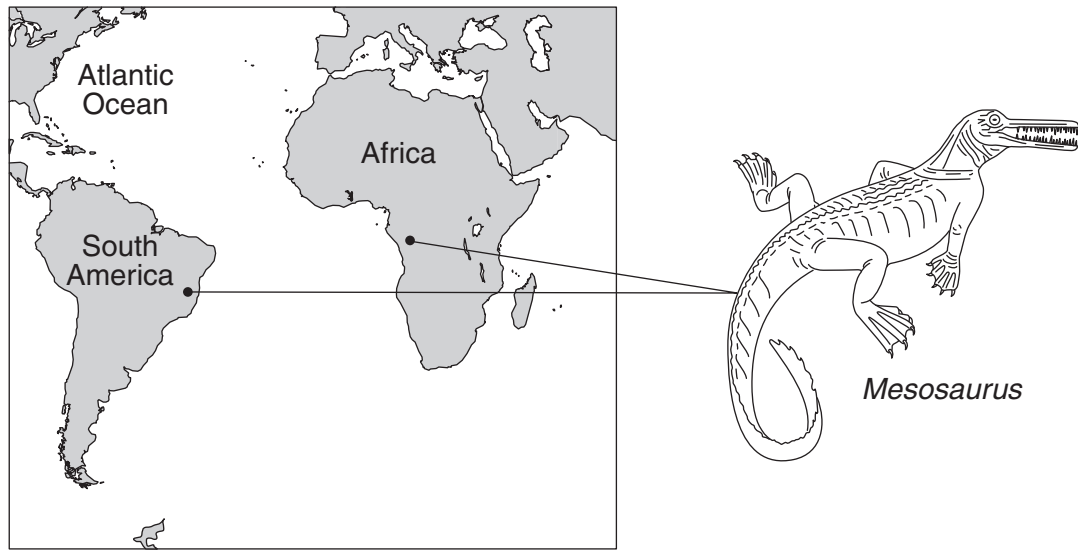

(Not drawn to scale)

Which statement best explains why these freshwater *Mesosaurus* fossils are found today in some rock layers in both South America and Africa?

- (1) *Mesosaurus* swam across the ocean between the continents.
- (2) The continents were once connected as a single landmass.
- (3) Global warming has been raising the sea level in the Atlantic Ocean.
- (4) The remains of *Mesosaurus* were carried across the ocean by predators.

34 A person uses a bow to shoot an arrow at a target. In which diagram does the bow and arrow have the greatest amount of potential energy?

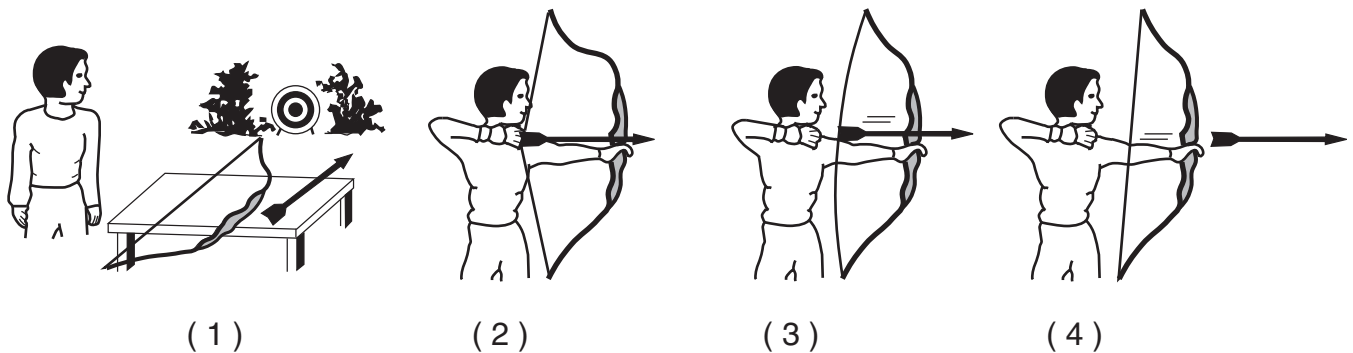

- 35 The diagram below shows 20 grams of two different materials, A and B, on a laboratory balance.

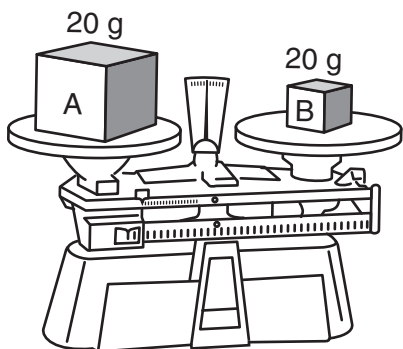

Compared to material A, material B has a different

- (1) density (3) phase
 (2) mass (4) shape
- 36 Which activity is an example of a chemical change?
- (1) dissolving table salt in water
 (2) hammering aluminum into thin sheets
 (3) melting gold to make jewelry
 (4) burning wood to produce ashes

Base your answers to questions 37 and 38 on the diagram below and on your knowledge of science. The diagram represents four processes, labeled A, B, C, and D, that occur when water changes phase.

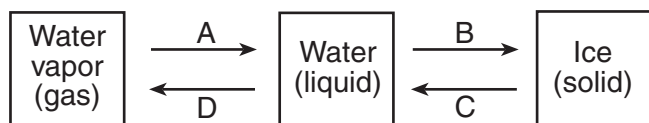

- 37 Which process is represented by B?
- (1) condensing (3) freezing
 (2) evaporating (4) melting
- 38 Which two processes increase the motion of the molecules?
- (1) A and B (3) C and D
 (2) B and C (4) D and A

- 39 Which resource is considered *nonrenewable*?
- (1) wind power (3) moving water
 (2) solar energy (4) fossil fuels

- 40 The arrows in the diagram below show the circulation of air on a sunny day.

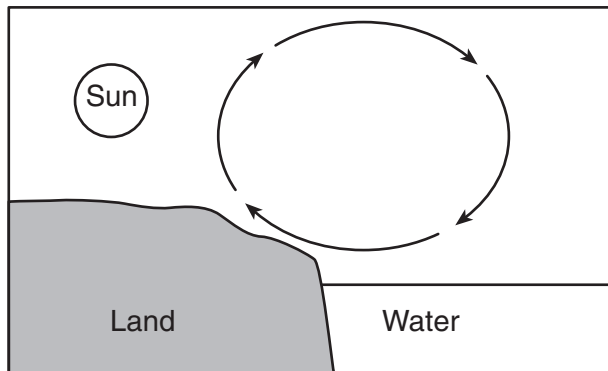

The air circulation shown is caused by

- (1) both hot air and cool air sinking
 (2) both hot air and cool air rising
 (3) hot air sinking and cool air rising
 (4) hot air rising and cool air sinking
- 41 Which form of energy are x rays and ultraviolet light?
- (1) nuclear (3) electromagnetic
 (2) heat (4) chemical
- 42 Sound will *not* travel in a
- (1) solid (3) gas
 (2) liquid (4) vacuum
- 43 A student pushes against a tree with a force of 10 newtons (N). The tree does *not* move. What is the amount of force exerted by the tree on the student?
- (1) 0 N (3) 10 N
 (2) 5 N (4) 20 N

44 The picture below shows a bird landing at a bird feeder outside a window.

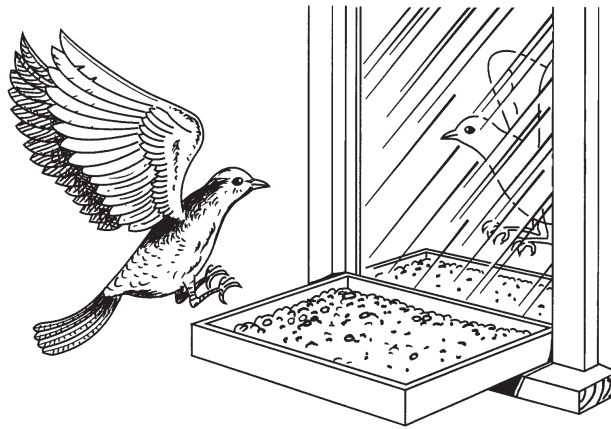

The image of this bird in the window is the result of light being

- (1) absorbed
- (2) reflected
- (3) transmitted
- (4) refracted

45 The diagram below shows a game where players try to move a metal needle through three metal paper clips without letting the needle touch the clips. A bulb lights when the needle touches a paper clip, signaling that the player has lost.

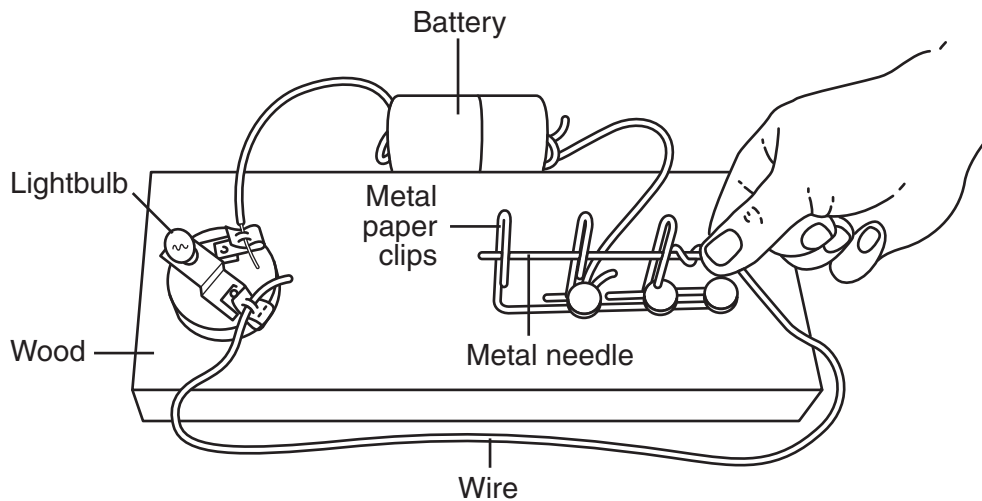

Why does the bulb light when the needle touches a paper clip?

- (1) Convection cells are produced.
 - (2) Vibrations set up wavelike disturbances.
 - (3) A circuit is completed.
 - (4) A phase change occurs.
-

Part II

Directions (46–83): Record your answers in the space provided below each question.

Base your answers to questions 46 and 47 on the information below and on your knowledge of science.

Solutions of acids and solutions of bases have different properties. Indicators are chemicals that change color when a solution becomes more acidic or more basic. Some indicators and their colors are shown in the table below.

Some Indicators and Their Colors

Indicator	Color in Acidic Solution	Color in Neutral Solution	Color in Basic Solution
bromthymol blue	yellow	green	blue
litmus	red	purple	blue
phenolphthalein	colorless	colorless	pink

- 46 Explain why testing a solution with only phenolphthalein would *not* show whether the solution is acidic or neutral. [1]

- 47 Scientists used these three indicators to test a sample of lake water. The results were:

bromthymol blue test — yellow
litmus test — red
phenolphthalein test — colorless

The best conditions for a certain fish species occur when the lake water is neutral, not acidic or basic. Do the test results show that the lake water is a good environment for this species of fish?

Circle one: Yes No

Explain your answer. [1]

Base your answers to questions 48 and 49 on the graph below and on your knowledge of science. The graph shows the concentration of carbon dioxide in parts per million (ppm) in the atmosphere over several years.

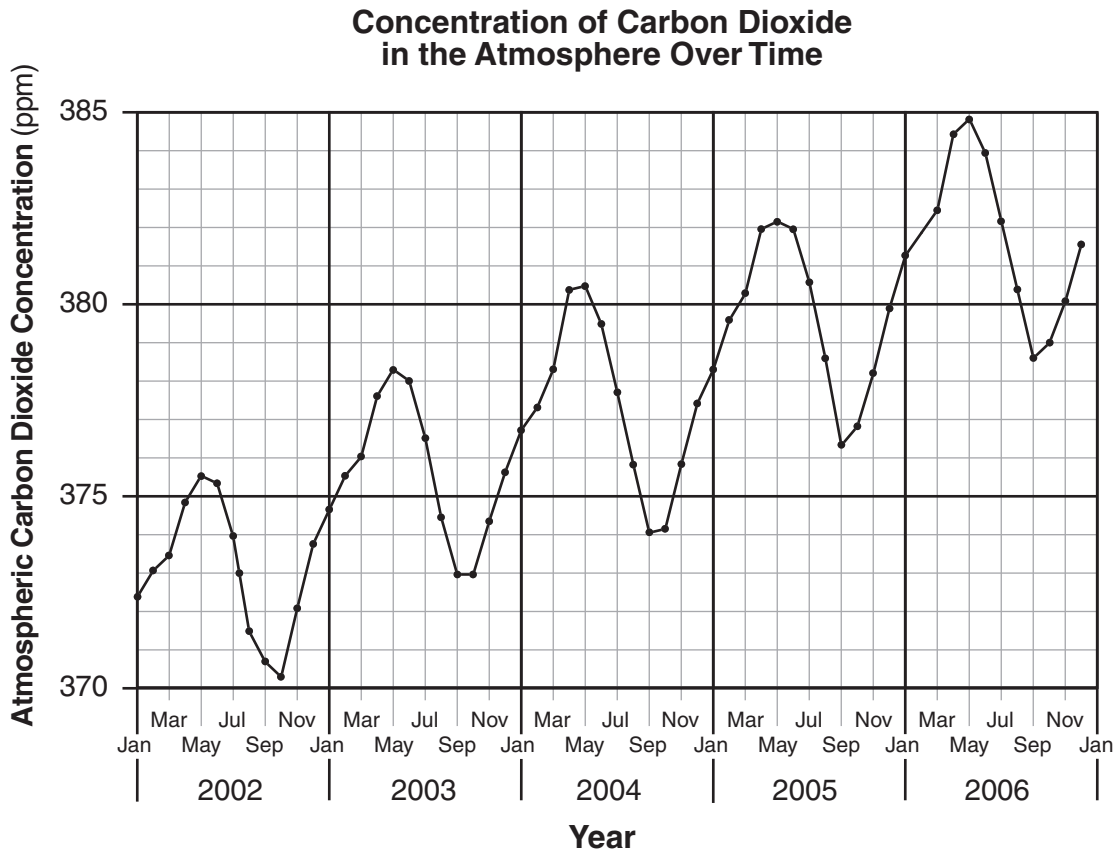

<http://serc.carleton.edu/introgeo/interactive/examples/co2.html>

48 Based on the graph, predict the month in 2007 when the concentration of atmospheric carbon dioxide would have been highest. [1]

49 The general trend in the graph shows an increase in atmospheric carbon dioxide levels from 2002 to 2006. Describe *one* human activity that may have produced this increase. [1]

Base your answers to questions 50 through 52 on the graph below and on your knowledge of science. The graph shows the solubility curves for a solid solute and a gaseous solute.

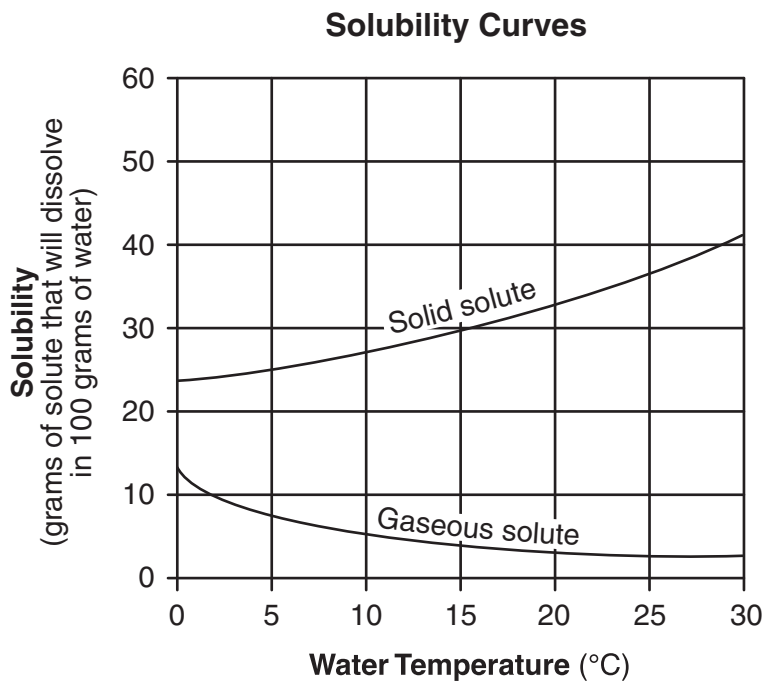

50 How many grams of the solid solute will dissolve in 100 grams of water at 25°C? [1]

_____ g

51 Describe the relationship between water temperature and the solubility of the gaseous solute from 0°C to 15°C. [1]

52 State *one* way to increase the rate at which a solid solute dissolves in 100 grams of water. [1]

Base your answers to questions 53 through 55 on the table of mineral properties below and on your knowledge of science.

Properties of Some Minerals

Mineral	Properties		
	Hardness	Streak	Reaction with Acid
calcite	soft	colorless or white	bubbles
chalcopryrite	hard	gray or black	rotten-egg smell
feldspar	hard	colorless or white	no reaction
galena	soft	gray or black	rotten-egg smell
graphite	soft	gray or black	no reaction
gypsum	soft	colorless or white	no reaction
hornblende	hard	gray or black	no reaction

53 Identify the mineral in the table that is hard, has a black streak, and has no reaction with acid. [1]

54 Compared to the chalcopryrite, which property of galena is different? [1]

55 Describe the test for determining the streak of most minerals. [1]

56 A group of students placed the same species of a water plant in five identical test tubes. The test tubes were filled with water and placed at different distances from a light source. After a few minutes, bubbles began to appear in the test tubes, indicating that photosynthesis was occurring. The students counted and recorded the number of bubbles per minute that appeared in each of the test tubes. The results are shown in the data table below.

**Photosynthesis in a Species
of Water Plant**

Distance from Light Source (cm)	Number of Bubbles per Minute
10	45
30	30
50	19
70	6
100	1

Predict the number of bubbles per minute that would appear if a test tube were placed 80 cm from the light source. [1]

_____ **bubbles per minute**

Base your answers to questions 57 through 59 on the food web below and on your knowledge of science.

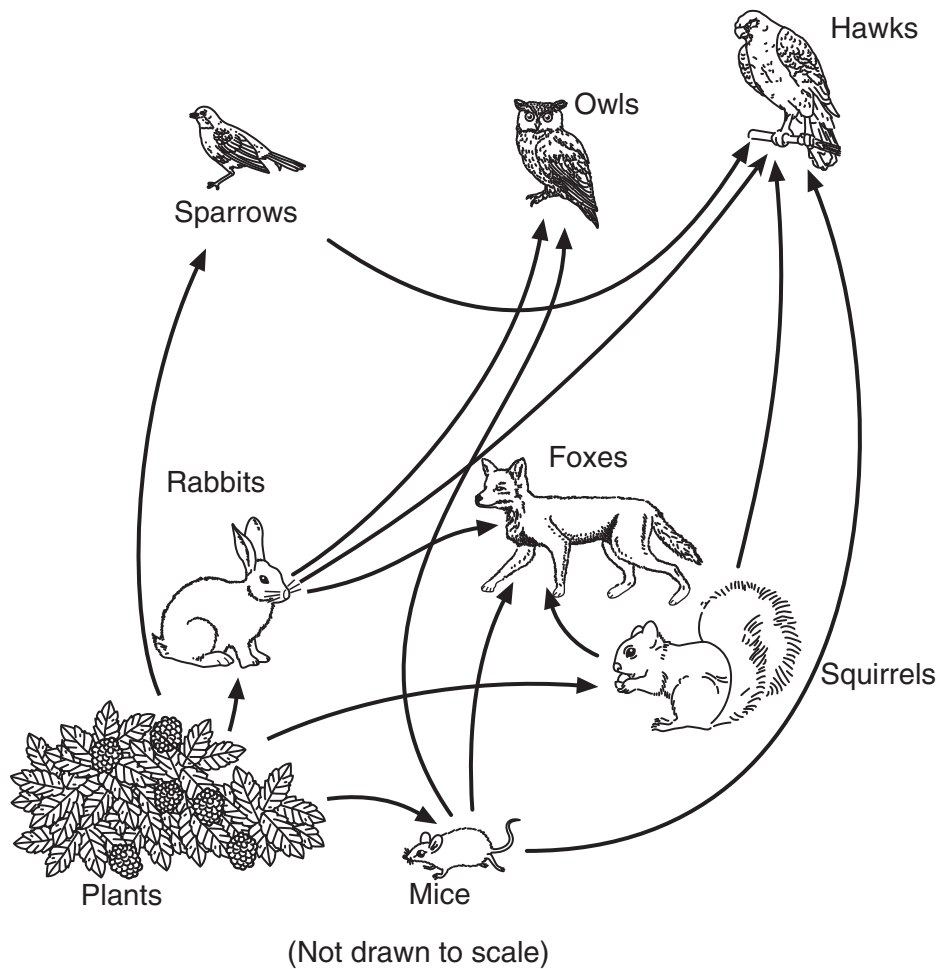

57 Identify *two* consumers in this food web that eat producers. [1]

_____ and _____

58 Explain why the foxes shown in this food web are categorized as carnivores. [1]

59 Both owls and hawks eat mice. Explain why the removal of mice from this food web would likely affect owls more than hawks. [1]

60 The diagram below shows cells from two different organisms. Several major cell structures are labeled.

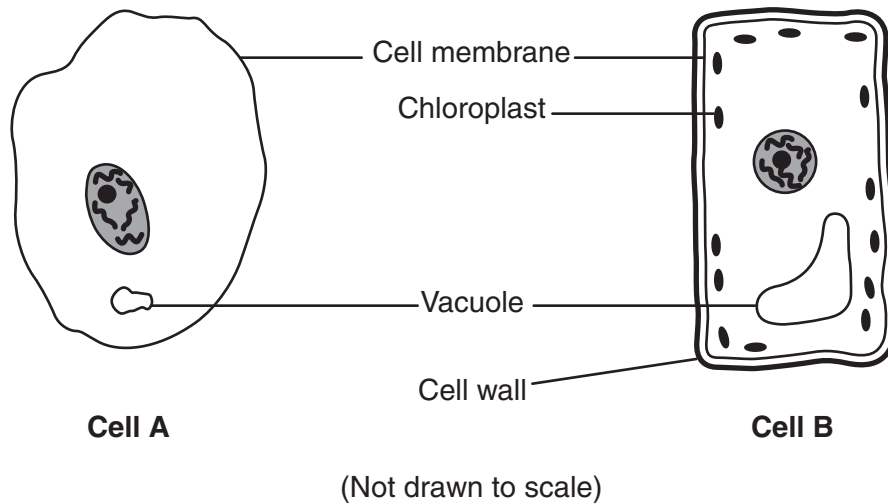

State *two* reasons why cell *B* is classified as a plant cell. [2]

- (1) _____
- (2) _____

61 The table below lists two structures in the human digestive system and two functions of each. Complete the table by circling the type of digestion represented by *each* function described. [2]

Structure	Function	Type of Digestion
mouth	teeth grind food	mechanical digestion chemical digestion
	saliva changes starch to sugar	mechanical digestion chemical digestion
stomach	acids allow enzymes to break down food	mechanical digestion chemical digestion
	food mixed and squeezed	mechanical digestion chemical digestion

Base your answers to questions 62 and 63 on the diagram below and on your knowledge of science. The diagram represents a human organ system. The arrows show the directions of blood flow. Letters *A* and *B* represent locations in this system.

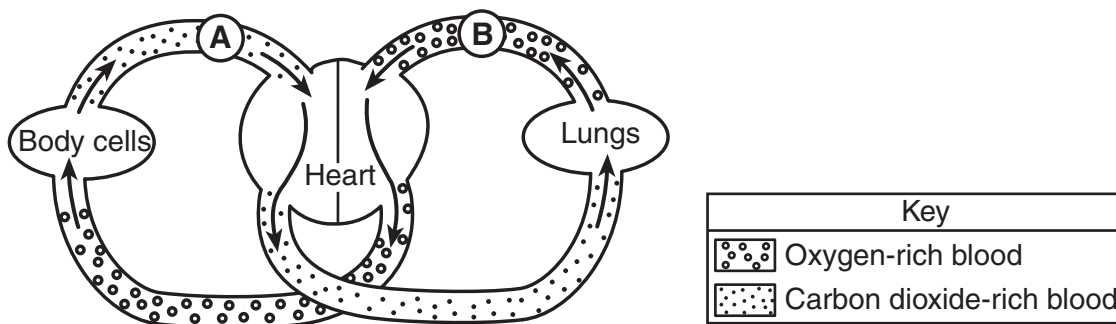

(Not drawn to scale)

62 Identify the human organ system responsible for the movement of blood shown in the diagram. [1]

_____ system

63 State *one* reason why blood at location *B* contains more oxygen than blood at location *A*. [1]

64 Scientists infer that a giant asteroid crashed into Earth approximately 65 million years ago, contributing to the extinction of dinosaurs and many other life-forms. Identify *one* form of evidence scientists have found that implies dinosaurs existed in the past. [1]

Base your answers to questions 65 and 66 on the diagram below and on your knowledge of science. The diagram shows a process that occurs in a male organism. Four stages in the process are labeled A, B, C, and D.

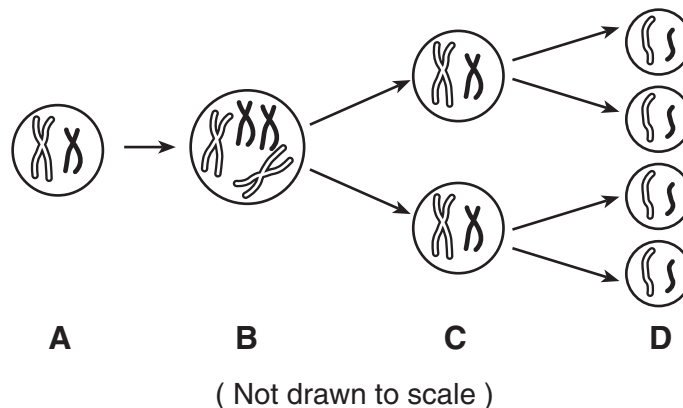

65 What type of cell is formed in this male organism at stage D? [1]

66 How does the number of chromosomes in the cell at A typically compare to the number of chromosomes in one of the cells at D? [1]

67 The diagram below shows the major types of ecological communities (biomes) found at different latitudes.

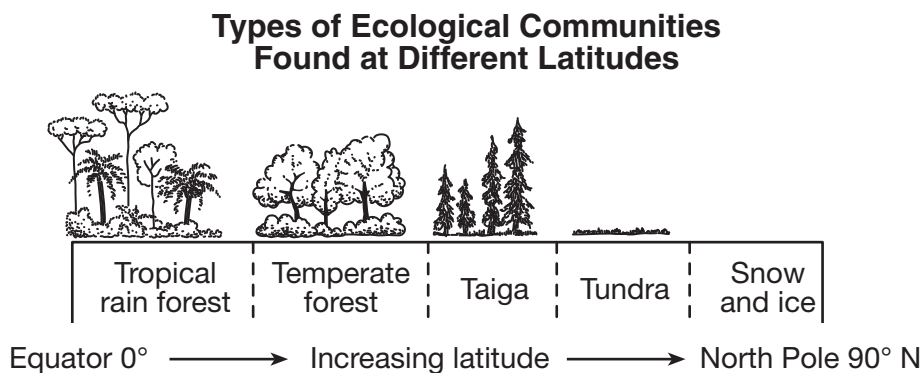

Explain why tropical rain forests are found near Earth's equator but *not* near the North Pole. [1]

Base your answers to questions 68 and 69 on the diagram below and on your knowledge of science. The diagram shows a plant that carries out photosynthesis.

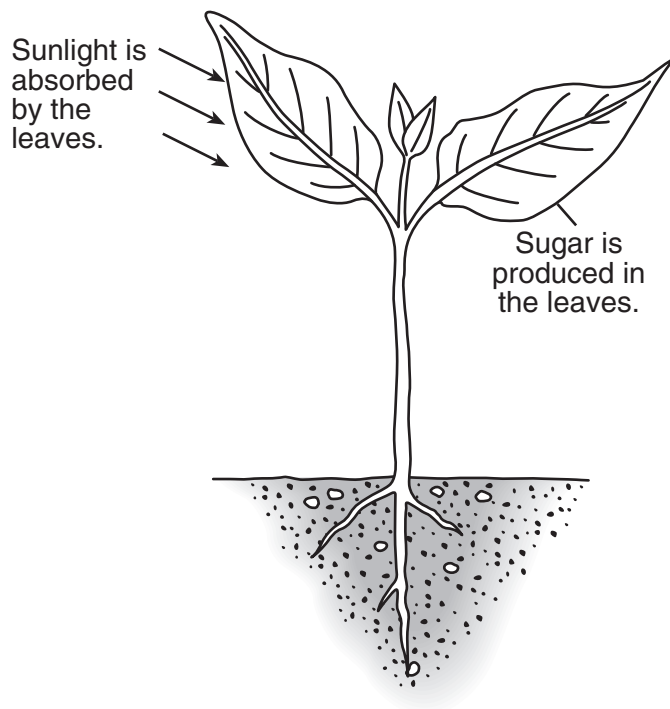

68 Sunlight is absorbed by the leaves. What *two* substances are also taken in by the plant for photosynthesis to occur? [1]

_____ and _____

69 Identify *one* product, other than sugar, that results from the process of photosynthesis. [1]

Base your answers to questions 70 and 71 on the diagram below and on your knowledge of science. The diagram shows one type of power facility that provides electricity for use in houses.

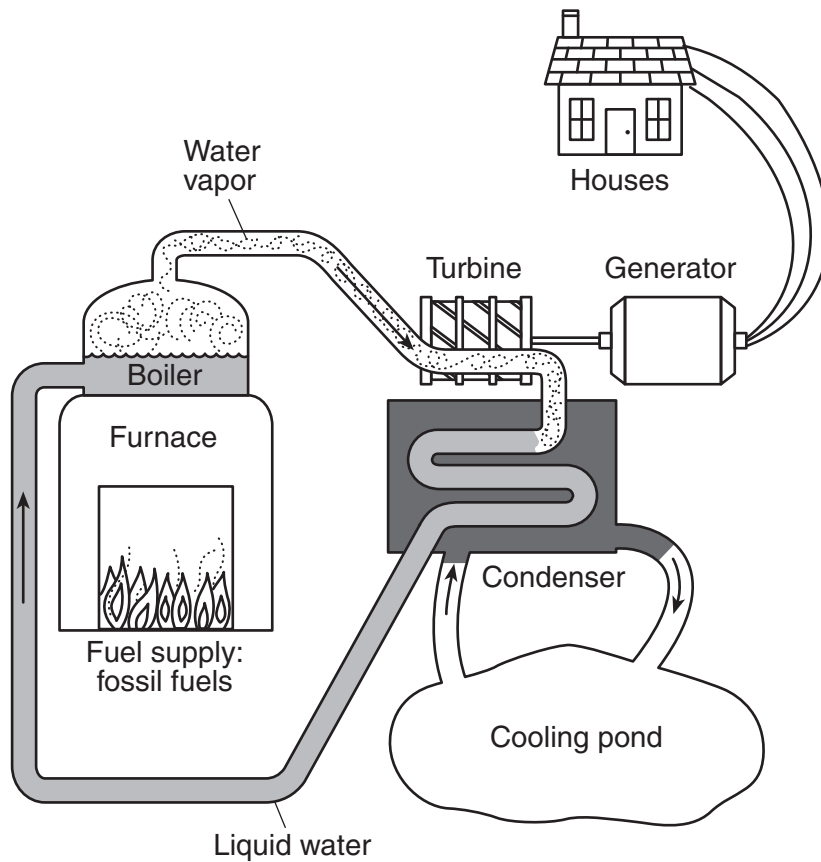

(Not drawn to scale)

70 What phase change occurs in the boiler? [1]

_____ phase to _____ phase

71 Identify *one* fossil fuel that may be burned in the furnace shown. [1]

72 The contour map below shows a hill. Two elevations are labeled. Place an **X** on the map where an elevation of 430 feet could be located. [1]

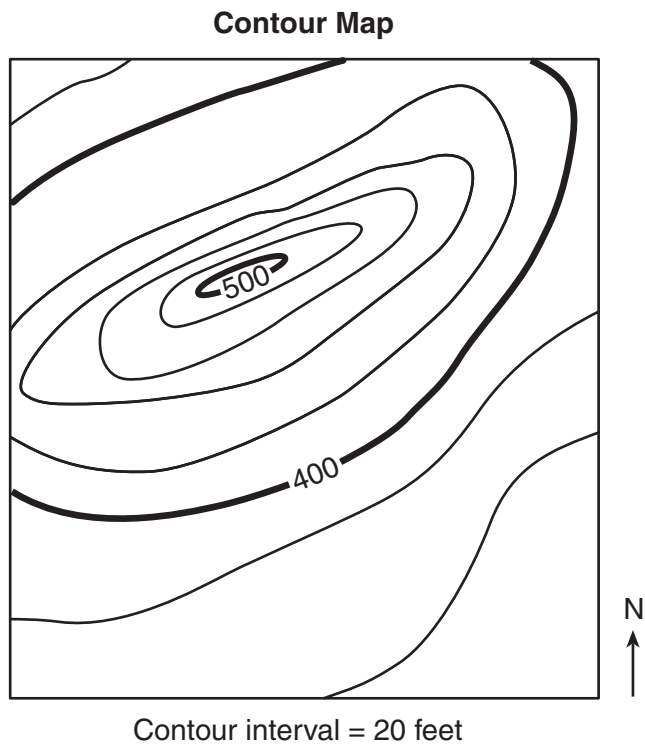

Base your answers to questions 73 and 74 on the map below and on your knowledge of science. The map shows a region of Earth containing volcanoes and tectonic plate boundaries.

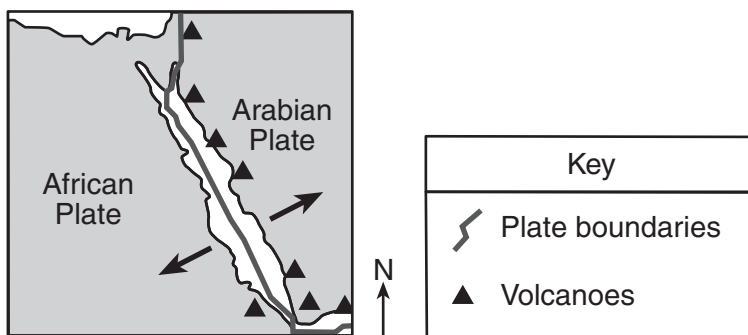

73 What do the arrows on the map represent? [1]

74 Identify *one* harmful environmental change that occurs when a volcano erupts. [1]

Base your answers to questions 75 and 76 on the map below and on your knowledge of science. Points *A* and *B* are locations on the map.

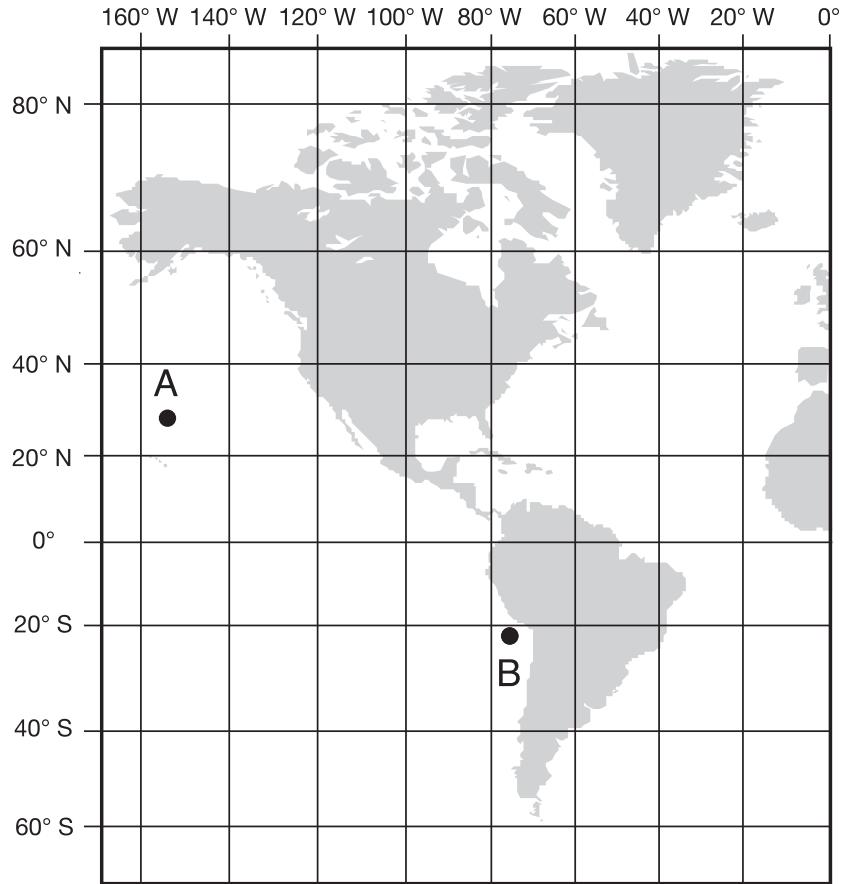

75 On the map above, place an **X** at 40° N 20° W. [1]

76 Explain why location *B* will experience sunrise before location *A*. [1]

Base your answers to questions 77 and 78 on the map below and on your knowledge of science. The map shows a low-pressure system (L) over New York State in July.

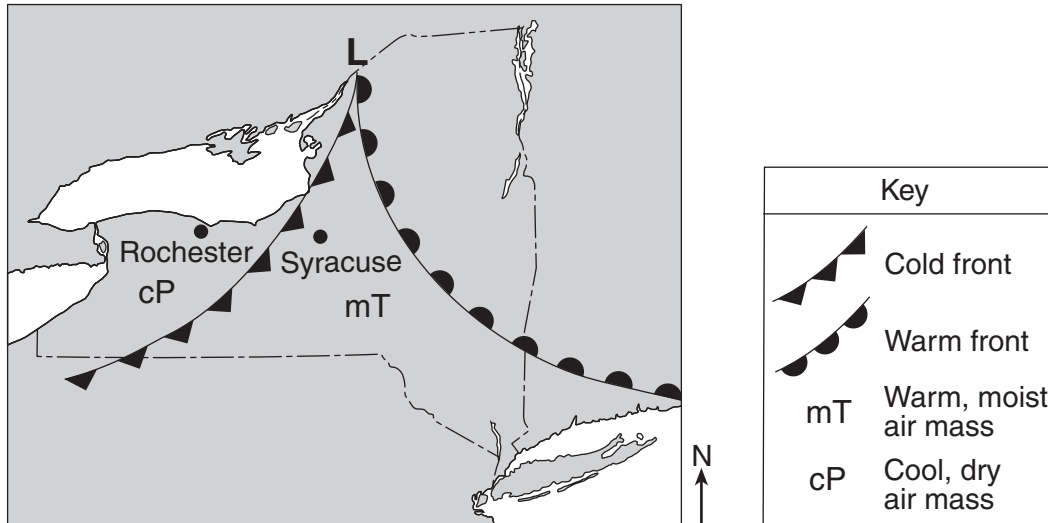

77 Describe *one* weather condition that was most likely produced along the fronts as this low-pressure system moved across New York State in July. [1]

78 Explain why this low-pressure system causes the temperature to be warmer in Syracuse than in Rochester. [1]

Base your answers to questions 79 and 80 on the portion of the Periodic Table of the Elements shown below and on your knowledge of science.

Portion of the Periodic Table of the Elements

Key

28	— approximate atomic mass
Si	— symbol
Silicon	— name
14	— atomic number

		Groups									
		13	14	15	16	17	18				
		11	12	13	14	15	16	17	18		
				11	12	13	14	15	16	17	18
				64	65	70	73	75	79	80	84
		Cu	Zn	Ga	Ge	As	Se	Br	Kr		
		Copper	Zinc	Gallium	Germanium	Arsenic	Selenium	Bromine	Krypton		
		29	30	31	32	33	34	35	36		
		108	112	115	119	122	128	127	131		
		Ag	Cd	In	Sn	Sb	Te	I	Xe		
		Silver	Cadmium	Indium	Tin	Antimony	Tellurium	Iodine	Xenon		
		47	48	49	50	51	52	53	54		

79 The chemical symbols of four different elements are listed below.

Cd Cu Br P

Write the symbol of these four elements in the appropriate box in the chart below to indicate whether the element is a metal or a nonmetal. [1]

Element Classification	Element Symbol
metals	
nonmetals	

80 In which group of the Periodic Table of the Elements are the noble gases located? [1]

Group _____

Base your answers to questions 81 and 82 on the diagram below and on your knowledge of science. The diagram shows an overhead view of two trains, A and B, traveling beside each other in the direction shown by the arrow.

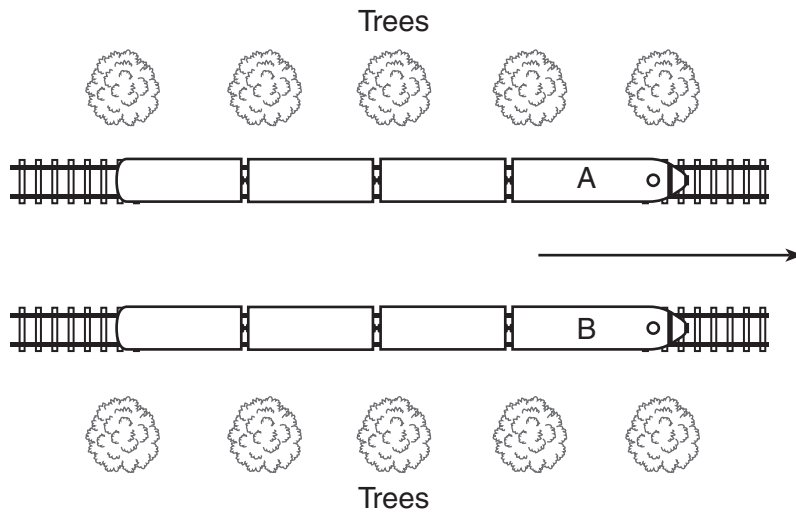

81 When a passenger in train A looks at a passenger directly across in train B, it appears that train B is not moving, even though both trains are moving. How does the speed of train A compare to the speed of train B? [1]

82 What visual evidence observed by the passengers in either train lets them know that their train is moving in the direction indicated by the arrow? [1]

83 The diagram below shows a lever that can be used to lift a person. The fulcrum is the point on which the lever pivots.

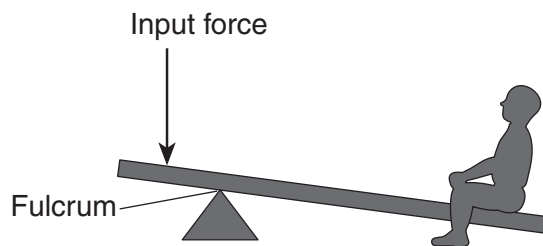

Describe *one* change that could be made to the lever to *decrease* the input force needed to lift the person. [1]

GRADE 8 INTERMEDIATE-LEVEL SCIENCE

For Teacher Use Only

Part II Credits

Question	Maximum Credit	Credit Allowed
46	1	
47	1	
48	1	
49	1	
50	1	
51	1	
52	1	
53	1	
54	1	
55	1	
56	1	
57	1	
58	1	
59	1	
60	2	
61	2	
62	1	
63	1	
64	1	
65	1	
66	1	
67	1	
68	1	
69	1	
70	1	
71	1	
72	1	
73	1	
74	1	
75	1	
76	1	
77	1	
78	1	
79	1	
80	1	
81	1	
82	1	
83	1	
Total	40	

Printed on Recycled Paper