

# INTEGRATED ALGEBRA

The University of the State of New York  
REGENTS HIGH SCHOOL EXAMINATION

# INTEGRATED ALGEBRA

Wednesday, January 26, 2011— 1:15 to 4:15 p.m., only

Student Name: \_\_\_\_\_

School Name: \_\_\_\_\_

Print your name and the name of your school on the lines above. Then turn to the last page of this booklet, which is the answer sheet for Part I. Fold the last page along the perforations and, slowly and carefully, tear off the answer sheet. Then fill in the heading of your answer sheet.

This examination has four parts, with a total of 39 questions. You must answer all questions in this examination. Write your answers to the Part I multiple-choice questions on the separate answer sheet. Write your answers to the questions in Parts II, III, and IV directly in this booklet. All work should be written in pen, except graphs and drawings, which should be done in pencil. Clearly indicate the necessary steps, including appropriate formula substitutions, diagrams, graphs, charts, etc.

The formulas that you may need to answer some questions in this examination are found at the end of the examination. This sheet is perforated so you may remove it from this booklet.

Scrap paper is not permitted for any part of this examination, but you may use the blank spaces in this booklet as scrap paper. A perforated sheet of scrap graph paper is provided at the end of this booklet for any question for which graphing may be helpful but is not required. You may remove this sheet from this booklet. Any work done on this sheet of scrap graph paper will *not* be scored.

When you have completed the examination, you must sign the statement printed at the end of the answer sheet, indicating that you had no unlawful knowledge of the questions or answers prior to the examination and that you have neither given nor received assistance in answering any of the questions during the examination. Your answer sheet cannot be accepted if you fail to sign this declaration.

**Notice...**

A graphing calculator and a straightedge (ruler) must be available for you to use while taking this examination.

The use of any communications device is strictly prohibited when taking this examination. If you use any communications device, no matter how briefly, your examination will be invalidated and no score will be calculated for you.

**DO NOT OPEN THIS EXAMINATION BOOKLET UNTIL THE SIGNAL IS GIVEN.**

## Part I

Answer all 30 questions in this part. Each correct answer will receive 2 credits. No partial credit will be allowed. For each question, write on the separate answer sheet the numeral preceding the word or expression that best completes the statement or answers the question. [60]

Use this space for computations.

1 Given:

$$X = \{1, 2, 3, 4\}$$

$$Y = \{2, 3, 4, 5\}$$

$$Z = \{3, 4, 5, 6\}$$

What is the intersection of sets  $X$ ,  $Y$ , and  $Z$ ?

(1)  $\{3, 4\}$

(3)  $\{3, 4, 5\}$

(2)  $\{2, 3, 4\}$

(4)  $\{1, 2, 3, 4, 5, 6\}$

2 Which graph could be used to find the solution of the system of equations  $y = 2x + 6$  and  $y = x^2 + 4x + 3$ ?

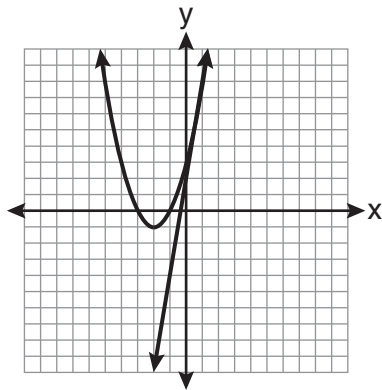

(1)

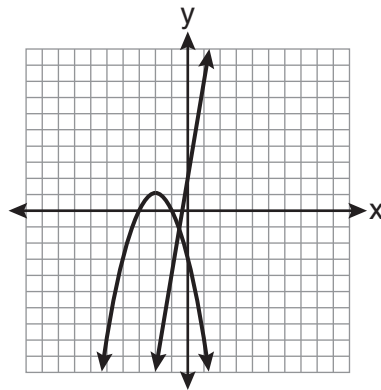

(3)

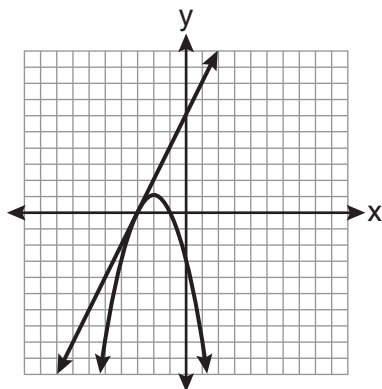

(2)

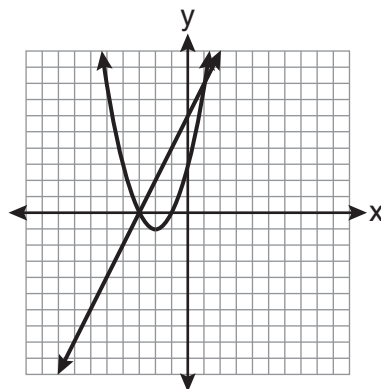

(4)

Use this space for  
computations.

- 3 What is the relationship between the independent and dependent variables in the scatter plot shown below?

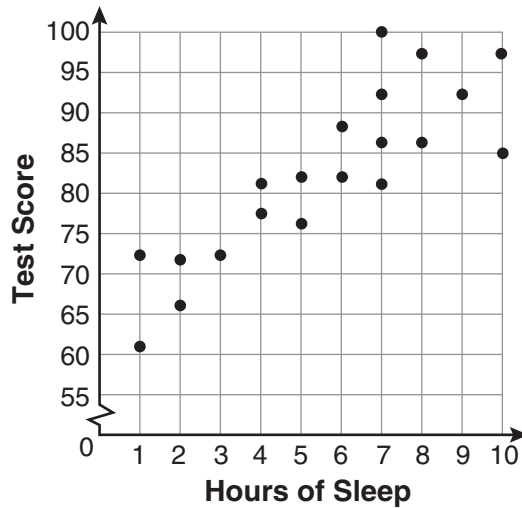

- (1) undefined correlation      (3) positive correlation  
(2) negative correlation      (4) no correlation
- 4 Tim ate four more cookies than Alice. Bob ate twice as many cookies as Tim. If  $x$  represents the number of cookies Alice ate, which expression represents the number of cookies Bob ate?
- (1)  $2 + (x + 4)$       (3)  $2(x + 4)$   
(2)  $2x + 4$       (4)  $4(x + 2)$
- 5 Which relation is a function?
- (1)  $\{(\frac{3}{4}, 0), (0, 1), (\frac{3}{4}, 2)\}$       (3)  $\{(-1, 4), (0, 5), (0, 4)\}$   
(2)  $\{(-2, 2), (-\frac{1}{2}, 1), (-2, 4)\}$       (4)  $\{(2, 1), (4, 3), (6, 5)\}$



9 Which ratio represents  $\sin x$  in the right triangle shown below?

Use this space for  
computations.

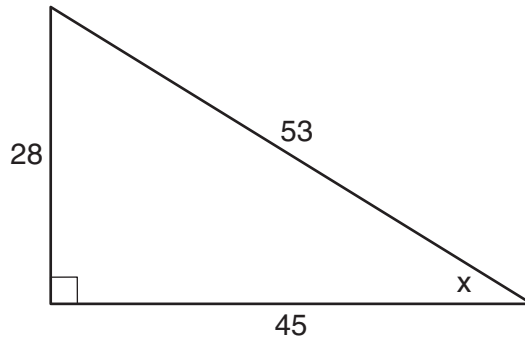

(1)  $\frac{28}{53}$

(3)  $\frac{45}{53}$

(2)  $\frac{28}{45}$

(4)  $\frac{53}{28}$

10 What is the value of the expression  $(a^3 + b^0)^2$  when  $a = -2$  and  $b = 4$ ?

(1) 64

(3) -49

(2) 49

(4) -64

Use this space for  
computations.

- 11 A student correctly graphed the parabola shown below to solve a given quadratic equation.

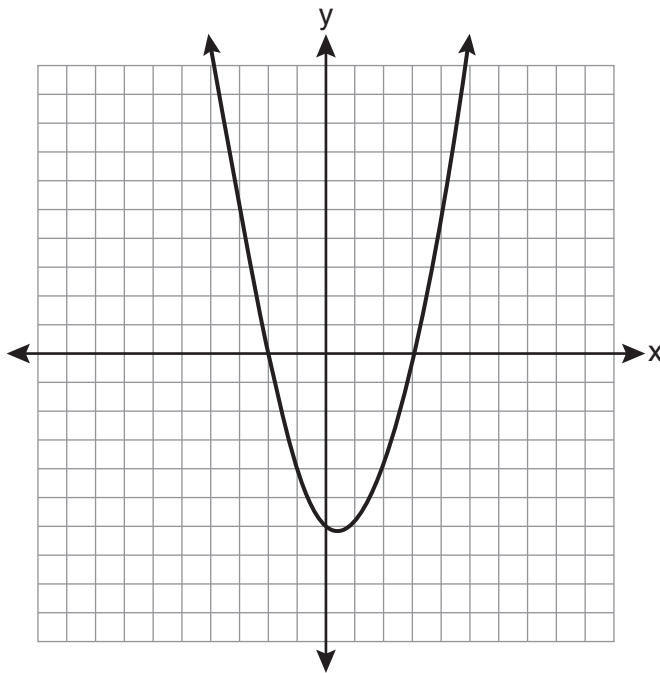

What are the roots of the quadratic equation associated with this graph?

- (1)  $-6$  and  $3$                       (3)  $-3$  and  $2$   
(2)  $-6$  and  $0$                       (4)  $-2$  and  $3$

- 12 Which value of  $x$  is the solution of the equation  $\frac{2}{3}x + \frac{1}{2} = \frac{5}{6}$ ?

- (1)  $\frac{1}{2}$                                   (3)  $\frac{2}{3}$   
(2)  $2$                                     (4)  $\frac{3}{2}$

Use this space for  
computations.

- 13 What is the range of the data represented in the box-and-whisker plot shown below?

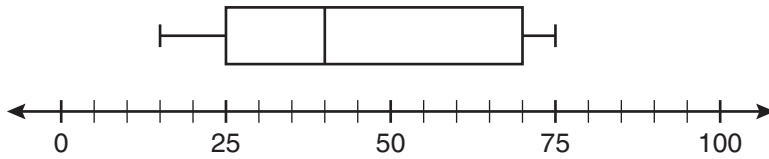

- (1) 40  
(2) 45  
(3) 60  
(4) 100
- 14 Which equation illustrates the associative property?

- (1)  $x + y + z = x + y + z$   
(2)  $x(y + z) = xy + xz$   
(3)  $x + y + z = z + y + x$   
(4)  $(x + y) + z = x + (y + z)$

- 15 Josh and Mae work at a concession stand. They each earn \$8 per hour. Josh worked three hours more than Mae. If Josh and Mae earned a total of \$120, how many hours did Josh work?

- (1) 6  
(2) 9  
(3) 12  
(4) 15

Use this space for  
computations.

16 Which data set describes a situation that could be classified as quantitative?

- (1) the phone numbers in a telephone book
- (2) the addresses for students at Hopkins High School
- (3) the zip codes of residents in the city of Buffalo, New York
- (4) the time it takes each of Mr. Harper's students to complete a test

17 Which is the graph of  $y = |x| + 2$ ?

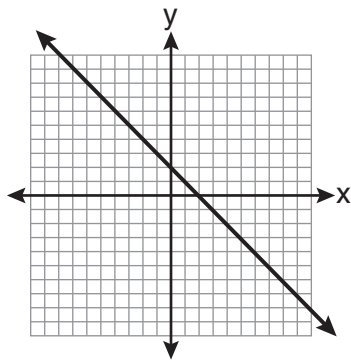

(1)

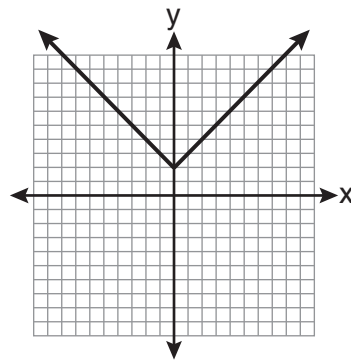

(3)

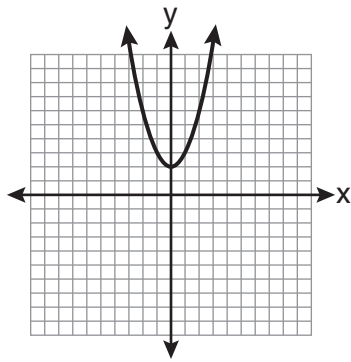

(2)

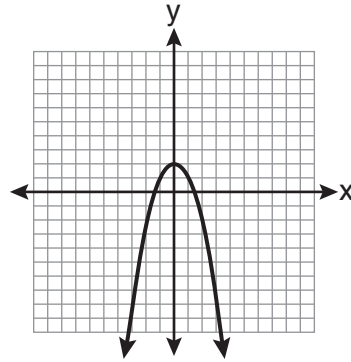

(4)



**Use this space for  
computations.**

**18** Sam's grades on eleven chemistry tests were 90, 85, 76, 63, 94, 89, 81, 76, 78, 69, and 97. Which statement is true about the measures of central tendency?

- (1) mean  $>$  mode                      (3) mode  $>$  median  
(2) mean  $<$  median                    (4) median = mean

**19** Which interval notation represents the set of all real numbers greater than 2 and less than or equal to 20?

- (1) (2,20)                              (3) [2,20)  
(2) (2,20]                              (4) [2,20]

**20** What is the sum of  $\frac{3}{2x}$  and  $\frac{7}{4x}$ ?

- (1)  $\frac{21}{8x^2}$                                   (3)  $\frac{10}{6x}$   
(2)  $\frac{13}{4x}$                                   (4)  $\frac{13}{8x}$

**21** What is  $3\sqrt{2} + \sqrt{8}$  expressed in simplest radical form?

- (1)  $3\sqrt{10}$                                 (3)  $5\sqrt{2}$   
(2)  $3\sqrt{16}$                                 (4)  $7\sqrt{2}$

Use this space for  
computations.

22 What is the slope of the line whose equation is  $3x - 7y = 9$ ?

(1)  $-\frac{3}{7}$

(3)  $-\frac{7}{3}$

(2)  $\frac{3}{7}$

(4)  $\frac{7}{3}$

23 The figure shown below is composed of two rectangles and a quarter circle.

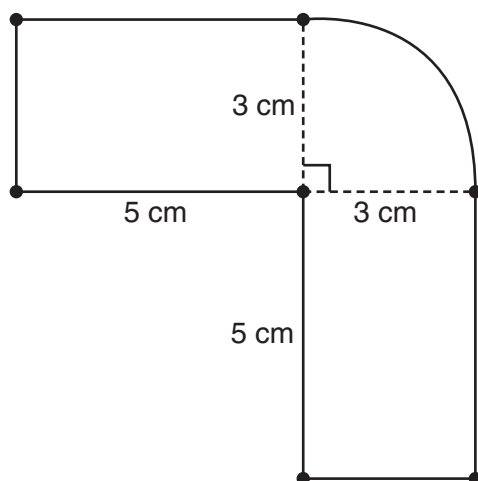

What is the area of this figure, to the *nearest square centimeter*?

(1) 33

(3) 44

(2) 37

(4) 58

24 The expression  $\frac{(10w^3)^2}{5w}$  is equivalent to

(1)  $2w^5$

(3)  $20w^5$

(2)  $2w^8$

(4)  $20w^8$

Use this space for  
computations.

25 If  $\frac{ey}{n} + k = t$ , what is  $y$  in terms of  $e$ ,  $n$ ,  $k$ , and  $t$ ?

(1)  $y = \frac{tn + k}{e}$                       (3)  $y = \frac{n(t + k)}{e}$

(2)  $y = \frac{tn - k}{e}$                       (4)  $y = \frac{n(t - k)}{e}$

26 What is the result when  $2x^2 + 3xy - 6$  is subtracted from  $x^2 - 7xy + 2$ ?

(1)  $-x^2 - 10xy + 8$                       (3)  $-x^2 - 4xy - 4$

(2)  $x^2 + 10xy - 8$                       (4)  $x^2 - 4xy - 4$

27 What is an equation of the axis of symmetry of the parabola represented by  $y = -x^2 + 6x - 4$ ?

(1)  $x = 3$                                       (3)  $x = 6$

(2)  $y = 3$                                       (4)  $y = 6$

28 Which equation has roots of  $-3$  and  $5$ ?

(1)  $x^2 + 2x - 15 = 0$                       (3)  $x^2 + 2x + 15 = 0$

(2)  $x^2 - 2x - 15 = 0$                       (4)  $x^2 - 2x + 15 = 0$



## Part II

Answer all 3 questions in this part. Each correct answer will receive 2 credits. Clearly indicate the necessary steps, including appropriate formula substitutions, diagrams, graphs, charts, etc. For all questions in this part, a correct numerical answer with no work shown will receive only 1 credit. [6]

- 31 Roberta needs ribbon for a craft project. The ribbon sells for \$3.75 per yard. Find the cost, in dollars, for 48 inches of the ribbon.

- 32** The square dart board shown below has a side that measures 40 inches. The shaded portion in the center is a square whose side is 15 inches. A dart thrown at the board is equally likely to land on any point on the dartboard.

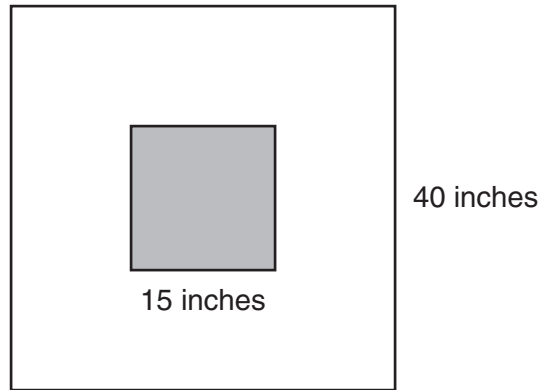

Find the probability that a dart hitting the board will *not* land in the shaded area.

- 33** As shown in the diagram below, a ladder 5 feet long leans against a wall and makes an angle of  $65^\circ$  with the ground. Find, to the *nearest tenth of a foot*, the distance from the wall to the base of the ladder.

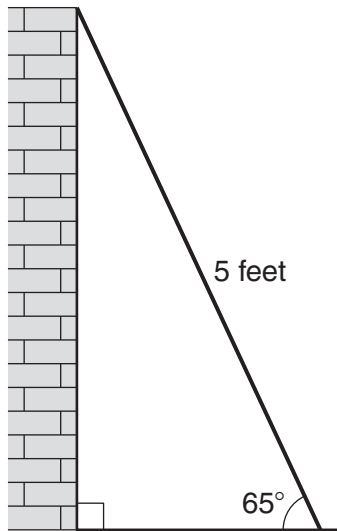

### Part III

Answer all 3 questions in this part. Each correct answer will receive 3 credits. Clearly indicate the necessary steps, including appropriate formula substitutions, diagrams, graphs, charts, etc. For all questions in this part, a correct numerical answer with no work shown will receive only 1 credit. [9]

- 34 A line having a slope of  $\frac{3}{4}$  passes through the point  $(-8,4)$ .  
Write the equation of this line in slope-intercept form.



**35** The test scores for 18 students in Ms. Mosher's class are listed below:

86, 81, 79, 71, 58, 87, 52, 71, 87, 87, 93, 64, 94, 81, 76, 98, 94, 68

Complete the frequency table below.

Interval	Tally	Frequency
51–60		
61–70		
71–80		
81–90		
91–100		

Draw and label a frequency histogram on the grid below.

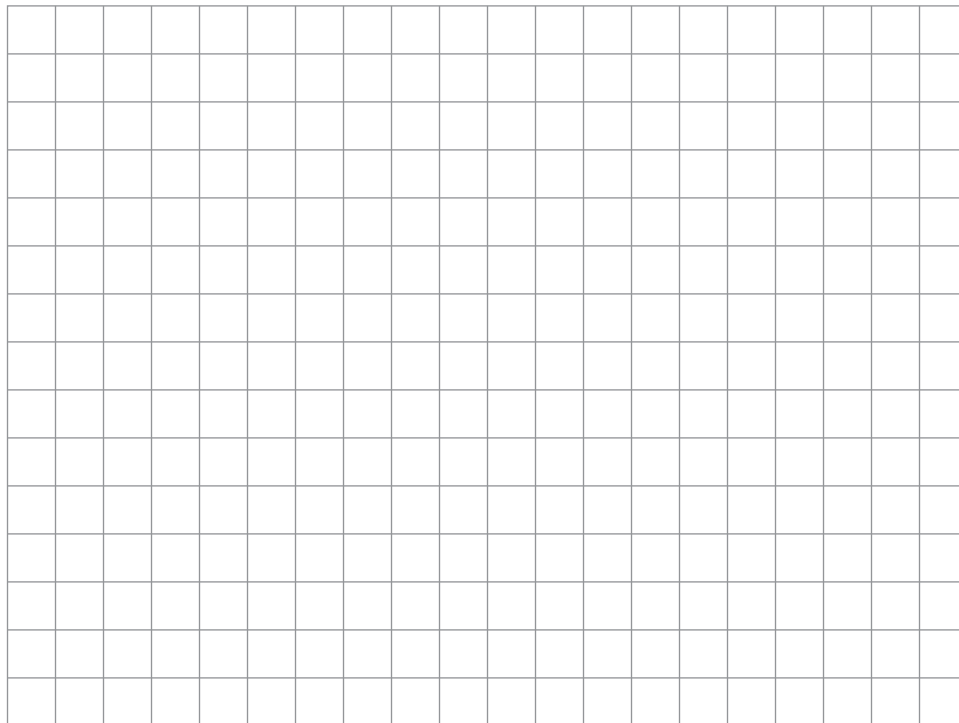

**36** Solve algebraically for  $x$ :  $\frac{x+2}{6} = \frac{3}{x-1}$

## Part IV

Answer all 3 questions in this part. Each correct answer will receive 4 credits. Clearly indicate the necessary steps, including appropriate formula substitutions, diagrams, graphs, charts, etc. For all questions in this part, a correct numerical answer with no work shown will receive only 1 credit. [12]

- 37 An oil company distributes oil in a metal can shaped like a cylinder that has an actual radius of 5.1 cm and a height of 15.1 cm. A worker incorrectly measured the radius as 5 cm and the height as 15 cm. Determine the relative error in calculating the surface area, to the *nearest thousandth*.

**38** The Booster Club raised \$30,000 for a sports fund. No more money will be placed into the fund. Each year the fund will decrease by 5%. Determine the amount of money, to the *nearest cent*, that will be left in the sports fund after 4 years.

**39** Graph the following system of inequalities on the set of axes shown below and label the solution set  $S$ .

$$y > -x + 2$$

$$y \leq \frac{2}{3}x + 5$$

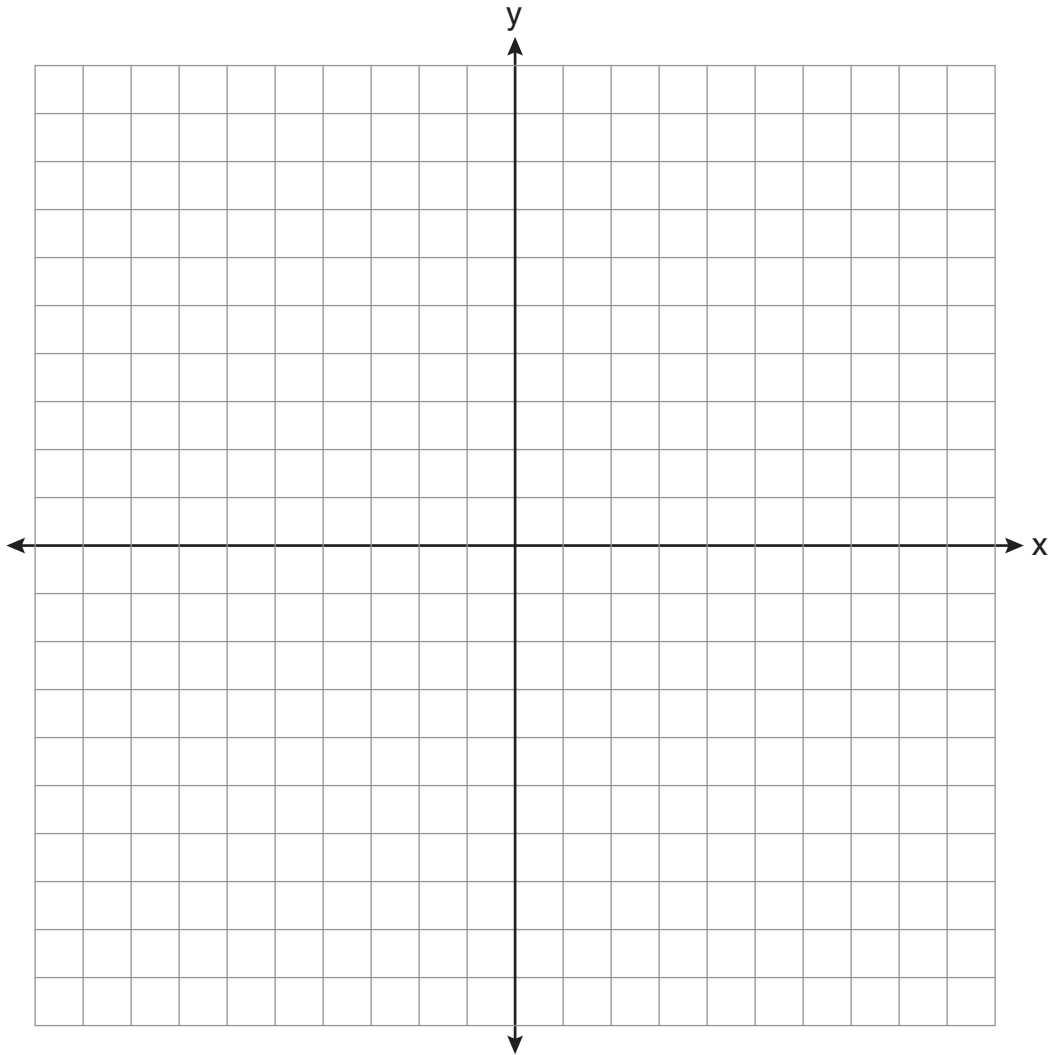



## Reference Sheet

Trigonometric Ratios

$$\sin A = \frac{\textit{opposite}}{\textit{hypotenuse}}$$

$$\cos A = \frac{\textit{adjacent}}{\textit{hypotenuse}}$$

$$\tan A = \frac{\textit{opposite}}{\textit{adjacent}}$$

Area

trapezoid  $A = \frac{1}{2}h(b_1 + b_2)$

Volume

cylinder  $V = \pi r^2 h$

Surface Area

rectangular prism  $SA = 2lw + 2hw + 2lh$

cylinder  $SA = 2\pi r^2 + 2\pi rh$

Coordinate Geometry

$$m = \frac{\Delta y}{\Delta x} = \frac{y_2 - y_1}{x_2 - x_1}$$

Tear Here

Tear Here

Tear Here

Tear Here



Scrap Graph Paper — This sheet will *not* be scored.

Tear Here

Tear Here

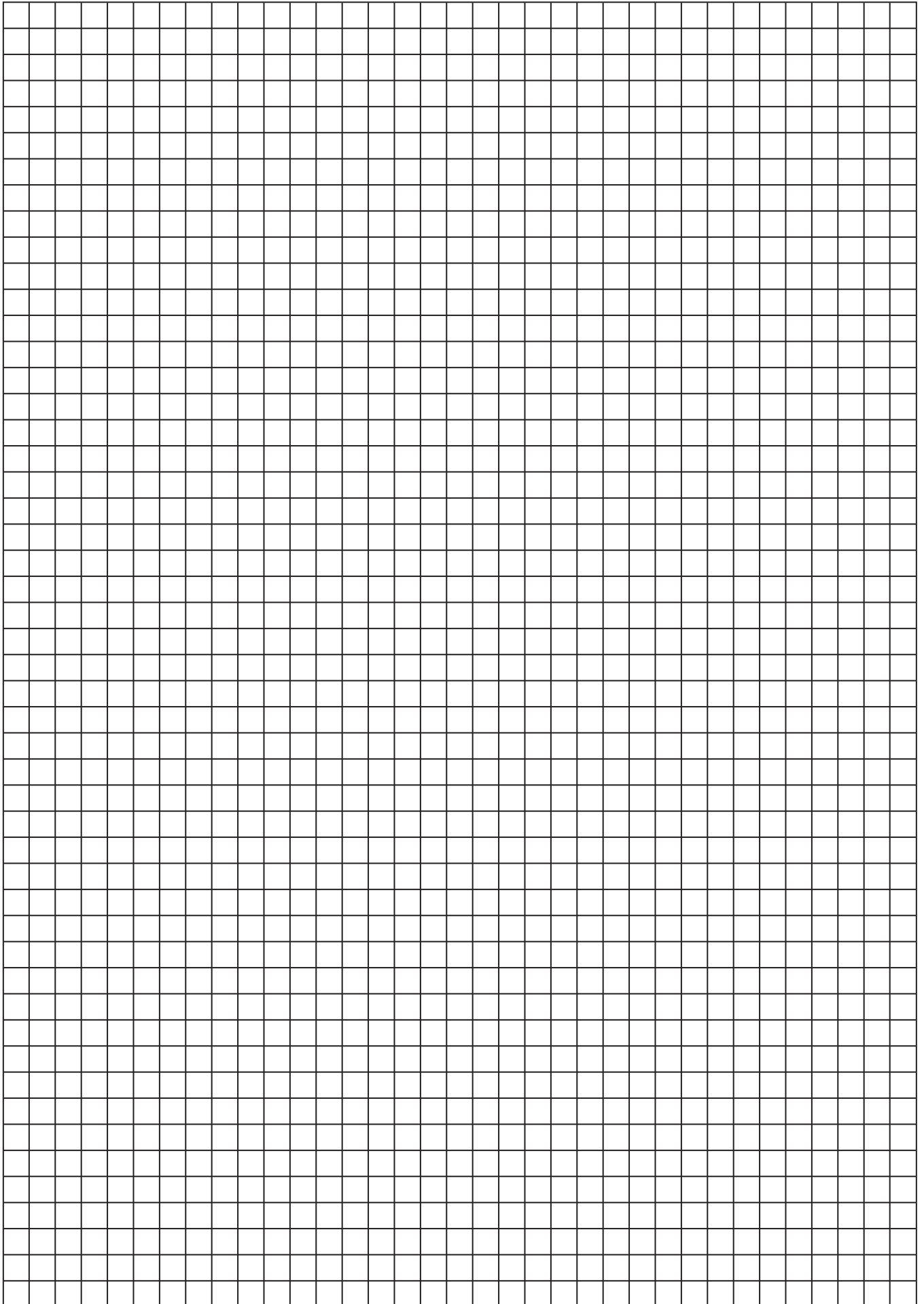

Scrap Graph Paper — This sheet will *not* be scored.

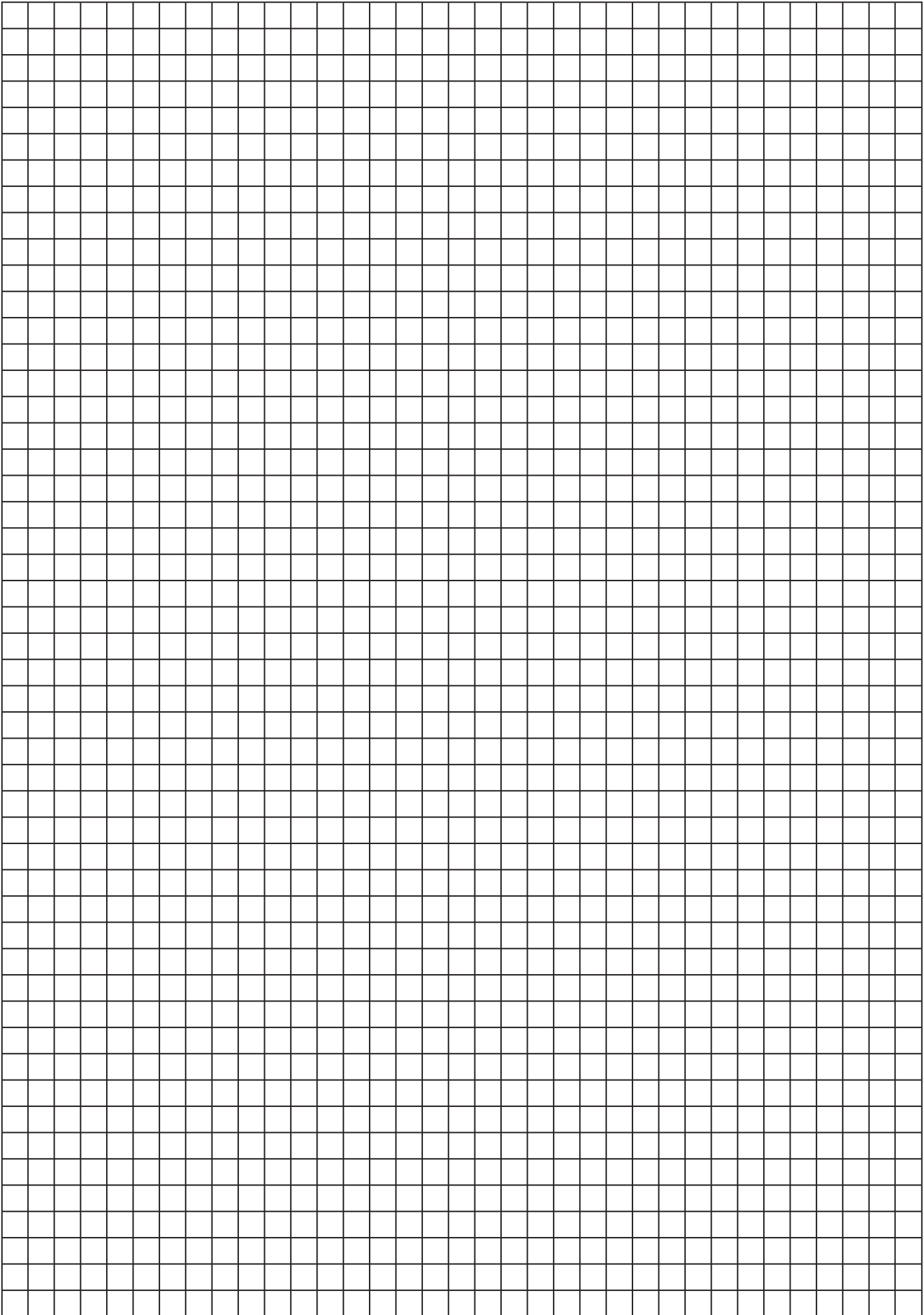

Tear Here

Tear Here

The University of the State of New York  
REGENTS HIGH SCHOOL EXAMINATION

# INTEGRATED ALGEBRA

Wednesday, January 26, 2011— 1:15 to 4:15 p.m., only

---

## ANSWER SHEET

Student ..... Sex:  Male  Female Grade .....

Teacher ..... School .....

**Your answers to Part I should be recorded on this answer sheet.**

### Part I

**Answer all 30 questions in this part.**

- |         |          |          |          |
|---------|----------|----------|----------|
| 1 ..... | 9 .....  | 17 ..... | 25 ..... |
| 2 ..... | 10 ..... | 18 ..... | 26 ..... |
| 3 ..... | 11 ..... | 19 ..... | 27 ..... |
| 4 ..... | 12 ..... | 20 ..... | 28 ..... |
| 5 ..... | 13 ..... | 21 ..... | 29 ..... |
| 6 ..... | 14 ..... | 22 ..... | 30 ..... |
| 7 ..... | 15 ..... | 23 ..... |          |
| 8 ..... | 16 ..... | 24 ..... |          |

**Your answers for Parts II, III, and IV should be written in the test booklet.**

**The declaration below must be signed when you have completed the examination.**

I do hereby affirm, at the close of this examination, that I had no unlawful knowledge of the questions or answers prior to the examination and that I have neither given nor received assistance in answering any of the questions during the examination.

---

Signature

