

The University of the State of New York

REGENTS HIGH SCHOOL EXAMINATION

LIVING ENVIRONMENT

Tuesday, January 22, 2019 — 1:15 to 4:15 p.m., only

Student Name _____

School Name _____

The possession or use of any communications device is strictly prohibited when taking this examination. If you have or use any communications device, no matter how briefly, your examination will be invalidated and no score will be calculated for you.

Print your name and the name of your school on the lines above.

A separate answer sheet for multiple-choice questions in Parts A, B–1, B–2, and D has been provided to you. Follow the instructions from the proctor for completing the student information on your answer sheet.

You are to answer all questions in all parts of this examination. Record your answers for all multiple-choice questions, including those in Parts B–2 and D, on the separate answer sheet. Record your answers for all open-ended questions directly in this examination booklet. All answers in this examination booklet should be written in pen, except for graphs and drawings, which should be done in pencil. You may use scrap paper to work out the answers to the questions, but be sure to record all your answers on the answer sheet or in this examination booklet as directed.

When you have completed the examination, you must sign the declaration printed on your separate answer sheet, indicating that you had no unlawful knowledge of the questions or answers prior to the examination and that you have neither given nor received assistance in answering any of the questions during the examination. Your answer sheet cannot be accepted if you fail to sign this declaration.

Notice ...

A four-function or scientific calculator must be available for you to use while taking this examination.

DO NOT START THIS EXAMINATION UNTIL THE SIGNAL IS GIVEN.

Part A

Answer all questions in this part. [30]

Directions (1–30): For *each* statement or question, record on the separate answer sheet the *number* of the word or expression that, of those given, best completes the statement or answers the question.

1 In single-celled organisms, materials are stored primarily in

- (1) ribosomes
- (2) mitochondria
- (3) nuclei
- (4) vacuoles

2 The human female reproductive cycle is regulated primarily by the

- (1) white blood cells of the circulatory system
- (2) muscle cells of the skeletal system
- (3) enzymes of the digestive system
- (4) hormones of the endocrine system

3 A photograph of a Siamese cat is shown below.

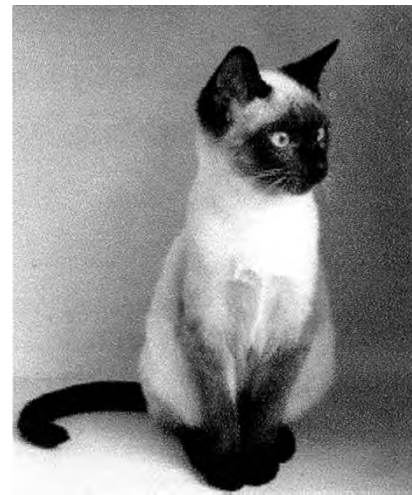

Source: www.pinterest.com/explorer/siamese/cats

Siamese cats have dark fur on areas of the body that are cooler and light fur on parts of the body that are warmer. The color differences in this Siamese cat are most likely due to

- (1) a decrease in glucose produced in areas with light fur
- (2) more DNA molecules being produced in areas with light fur
- (3) gene expression being influenced by the environment
- (4) mutations in the genes for eye color

4 When deciding on new environmental policies and laws, which term is used to describe the comparison between benefits and costs of human activities?

- (1) technology
- (2) trade-off
- (3) climate change
- (4) industrialization

5 If the grass in the front yard of an abandoned house is not cut for several years, the yard may become overgrown with taller grasses, bushes, and shrubs. This is an example of the process of

- (1) evolution
- (2) homeostasis
- (3) ecological succession
- (4) direct harvesting

6 The northern snakehead is a type of Asian fish that eats smaller fish and is adapted to a freshwater habitat.

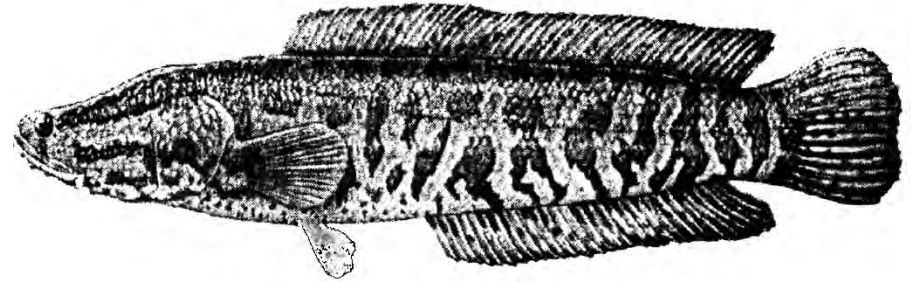

Source: <http://nas.er.usgs.gov/queries/factsheet.aspx?speciesid=2265>

The presence of these fish in American waters is of concern because it might offer too much competition to native

- (1) herbivores
- (2) predators
- (3) decomposers
- (4) producers

7 In a food web, which type of organism receives energy from the other three types?

- (1) producer
- (2) carnivore
- (3) decomposer
- (4) herbivore

8 An ameba is a single-celled, heterotrophic organism. In order to meet its energy needs, it relies directly on the interaction of which cell structures?

- (1) chloroplasts and the cell membrane
- (2) the cell membrane and mitochondria
- (3) nucleus and ribosomes
- (4) vacuoles and the nucleus

9 Recently, oil from a wrecked tanker resulted in a disaster in ecosystems containing many unique species. The potential loss of these species could result in

- (1) an increase in the variety of genetic material available
- (2) a decrease in organisms available for scientific research
- (3) an increase in the stability of the affected ecosystems
- (4) a decrease in pollution affecting the land and water

10 Which process occurs at each link in a food chain?

- (1) All the energy is stored in a newly made structure.
- (2) Some energy is released into the environment as heat.
- (3) Chemical energy is recycled.
- (4) Atoms cycle among living organisms, producing energy.

11 Genetic recombination, production of more offspring than can survive, and struggling with the challenges of the environment are all concepts associated with

- (1) natural selection
- (2) mitotic division
- (3) selective breeding
- (4) genetic engineering

12 Mistletoe is a plant that lives on the branches of trees. The mistletoe plant sends its roots in through the bark of trees and takes away water and minerals that the tree needs. In this situation, the mistletoe plant is

- (1) a parasite
- (2) a predator
- (3) a decomposer
- (4) an autotroph

13 An example of a population in which evolution could take place in a relatively short period of time could be

- (1) pathogenic bacteria exposed to antibiotics
- (2) oak trees in a stable ecosystem
- (3) elephants living in a wildlife preserve
- (4) algae grown under constant conditions

14 Butterflies exposed to radiation leaking from a damaged nuclear power plant in Japan have been observed to have malformed legs, antennae, and wings. For future butterfly generations to have these similar structural abnormalities, gene mutations must be present in the affected butterflies'

- (1) wing cells
- (2) body cells
- (3) antenna cells
- (4) sex cells

15 The diagram below illustrates the release of chemical A from a human cell in response to a specific stimulus.

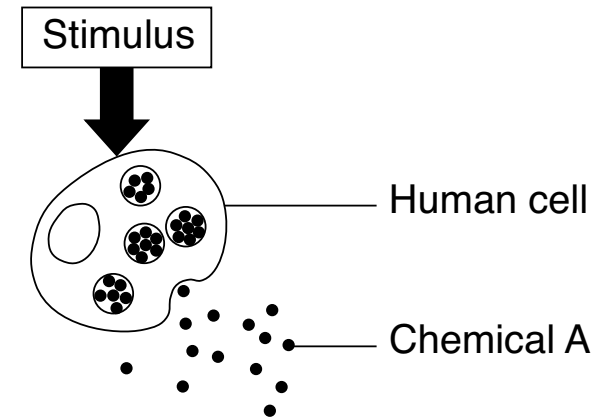

Source: Biology 8th ed., Pearson 2008, p. 859.

Which cell structure plays a direct role in the release of this chemical from the cell?

- (1) nucleus
- (2) ribosome
- (3) chloroplast
- (4) cell membrane

16 A rich variety of genetic material in an ecosystem will

- (1) reduce the biodiversity of the ecosystem
- (2) decrease the carrying capacity of the ecosystem
- (3) reduce the likelihood of future medical discoveries
- (4) increase the chances that some organisms will survive change

17 The process of sexual reproduction is an important part of the process of evolution. One reason for this is that meiosis and fertilization directly produce many new

- (1) antigens
- (2) variations
- (3) species
- (4) pathogens

18 A garlic bulb consisting of several smaller sections called cloves is shown below.

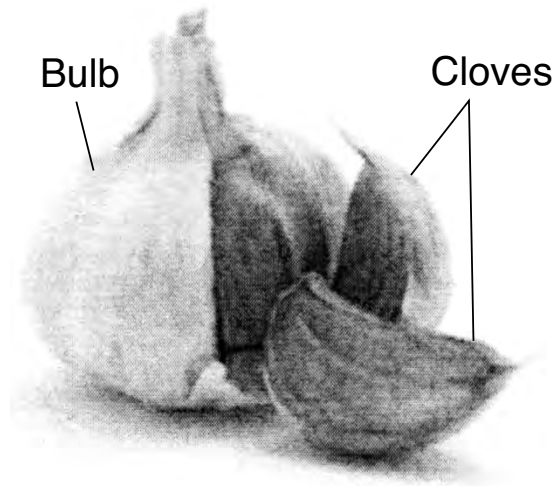

Source: www.sparkpeople.com/resource/nutrition_articles.asp?id=1791

If cloves are separated from the bulb and later planted in a garden, a new garlic bulb will grow from each. In this way, a home gardener could grow a whole crop of genetically identical garlic plants starting with one bulb.

As a result of this procedure, the gardener would

- (1) soon have several varieties of garlic growing in his garden
- (2) need to buy new garlic cloves each year in order to keep growing garlic
- (3) have to fertilize the female garlic plants each year so the garlic plants could produce their own cloves
- (4) need to be aware that if any of his garlic plants became diseased, it could very likely infect the entire crop

19 When humans place grass clippings and other yard waste in landfills, they are most directly interfering with the natural process of

- (1) recycling energy
- (2) the production of energy
- (3) recycling organic compounds
- (4) the production of organic compounds

20 Which statement is an example of a feedback mechanism in humans?

- (1) An increase in the level of blood sugar results in the pancreas increasing the amount of insulin it secretes.
- (2) Increased exposure to pathogenic bacteria results in an increase in the number of red blood cells produced.
- (3) An increase in exercise results in a decrease in the rate of respiration.
- (4) Increased muscle activity results in a decrease in heart rate.

21 Many disorders are due to the inability of an individual to break down a particular chemical. Sometimes these disorders can be treated by giving the affected individual the appropriate

- | | |
|--------------|-----------------|
| (1) enzymes | (3) chromosomes |
| (2) antigens | (4) organelles |

22 The removal of the predator populations from an ecosystem would most likely result in

- (1) a decrease in all the prey populations
- (2) an increase in all the producer populations
- (3) an increase in ecosystem diversity
- (4) a decrease in ecosystem diversity

23 Two new wind turbines have recently been built within the Eiffel Tower in Paris. The power that these turbines generate will be enough to power the entire first floor of the tower, including the restaurants, shops, and exhibits. A benefit of using wind power as an alternative source of energy is that it

- (1) is nonrenewable, so additional resources will be depleted by tower businesses
- (2) is renewable, so it will decrease the environmental impact of the tower businesses
- (3) increases the use of resources that cannot be renewed in the future
- (4) decreases the amount of fossil fuels available for future generations

24 In the photograph below, two fish are displaying a behavior commonly observed among pairs of rabbitfish. While one has its head down feeding on coral, the other remains upright, alert for predators.



Source: NY Times 9/28/15

This behavior continues to be present in the rabbitfish population because

- (1) this behavior was learned by observing other fish species
- (2) both fish could not fit into the small spaces in the coral
- (3) this behavior increases their chance of survival
- (4) the fish species needed to become alert to survive

25 The fast food industry in the United States buys many russet potatoes from farmers. Therefore, most potato farmers grow russet potatoes. If farmers continue to plant the same crop in the same fields year after year without putting additives into the soil, the end result could be

- (1) smaller yields in future years due to the loss of nutrients
- (2) larger potatoes because they will adapt to the soil
- (3) new varieties of potatoes because they will reproduce sexually
- (4) genetically engineered potatoes that are resistant to disease

26 A corn field includes corn plants, mice, hawks, and various insects, fungi, and bacteria. Which nutritional role is correctly paired with organisms that carry out that role?

- (1) heterotrophs – corn and bacteria
- (2) producers – insects and fungi
- (3) consumers – mice and insects
- (4) decomposers – hawks and bacteria

GO RIGHT ON TO THE NEXT PAGE ⇨

27 Each female housefly can lay approximately 500 eggs in a lifetime. She does this in several batches of about 75 to 150 eggs. Within a day, larvae (maggots) hatch from the eggs. They live and feed on organic material, such as garbage and feces. Scientists have calculated that a pair of flies beginning reproduction in April could be the ancestors of 191,010,000,000,000,000,000 flies by August.



Source: <http://www.publicdomainpictures.net/download-picture.php?adresar=10000&soubor+1-1220978631q1uO.jpg&id+1137>

Which statement best explains why this does *not* happen?

- (1) Mutations develop in the young flies.
- (2) Environmental factors keep the population in check.
- (3) Flies continue to reproduce in large numbers.
- (4) More female flies survive than male flies.

- 28 Which sequence best represents the levels of organization in a paramecium, a single-celled organism?
- (1) cells → tissues → organs → organ systems → organism
 - (2) organelles → organ systems → organism
 - (3) cells → organs → organ systems → organism
 - (4) organelles → organism
- 29 More than 100 years ago, Earth's atmosphere contained about 280 parts per million (ppm) of carbon dioxide. It is predicted that by the year 2050, the level of carbon dioxide in the atmosphere could reach 700 ppm, greatly increasing Earth's temperature. It has been suggested that growing more green plants would help to slow this increase. The best explanation for why increased numbers of plants would help is that plants
- (1) serve as food for herbivores
 - (2) serve as a nonrenewable energy resource
 - (3) remove carbon dioxide from the atmosphere during respiration
 - (4) remove carbon dioxide from the atmosphere during photosynthesis

30 The brown tree snake was accidentally introduced to the island of Guam during World War II. Since then, this snake has caused the extinction of twelve native bird species by eating their eggs and young.



Source: www.aquariumlife.com.au

One *negative* result of this snake's introduction was most likely

- (1) an increase in diversity as new species evolved to replace extinct species
 - (2) an increase in mosquitoes due to an increase in bird species in the environment
 - (3) a disruption of food chains and food webs in Guam's ecosystems
 - (4) an abundance of brown tree snakes as a food source for humans
-

Part B–1

Answer all questions in this part. [13]

Directions (31–43): For *each* statement or question, record on the separate answer sheet the *number* of the word or expression that, of those given, best completes the statement or answers the question.

GO RIGHT ON TO THE NEXT PAGE ⇨

Base your answers to questions 31 through 33 on the information below and on your knowledge of biology.

The Extinction of the Passenger Pigeon

In the early 1800s, the passenger pigeon was the most abundant bird species in North America. These pigeons traveled in flocks sometimes larger than a billion birds. The enormous flock sizes helped protect them from predation by foxes, lynx, owls, and falcons. It also helped them outcompete other animals (squirrels, chipmunks) for chestnuts and acorns, their main food source.

Unfortunately, this flocking behavior made the passenger pigeons easy targets for the people who killed them for food. The invention of the telegraph to broadcast flock locations to hunters and the expansion of the railroads to ship the pigeons to new food markets had devastating results. By the 1890s, their numbers had dwindled dramatically, with flocks only numbering in the hundreds. In 1914, the passenger pigeon became extinct when the last member of the species died at the Cincinnati Zoo.

- 31 Which factor contributed *least* to the extinction of the passenger pigeon species?
- (1) laws that banned the hunting of passenger pigeons to sell in new markets
 - (2) improved communication technology, which tracked the pigeon flocks
 - (3) expansion of the railroads, which opened up new markets for selling pigeons
 - (4) increased use of the passenger pigeons as a food source for humans
- 32 A direct result of the rapid decline of the passenger pigeon population was most likely
- (1) an increase in owl and falcon populations
 - (2) an increase in chipmunk and squirrel populations
 - (3) a decrease in fox and chipmunk populations
 - (4) a decrease in squirrel and chestnut tree populations

33 The extinction of the passenger pigeon illustrates that

- (1) humans are the only cause of species extinctions
 - (2) it takes hundreds of years for a species extinction
 - (3) the benefits of technology always outweigh the ecological risks
 - (4) human activities can irreversibly affect ecosystems
-

GO RIGHT ON TO THE NEXT PAGE ⇒

Base your answers to questions 34 and 35 on the information and diagram below and on your knowledge of biology.

To study how bacteria respond to antibiotics, four paper discs, three treated with different antibiotics and one treated with water, were placed on a nutrient source with bacteria and left for 24 hours. The water and the antibiotics on the discs diffused into the nutrient source. If the antibiotic stopped the bacteria from growing, a circular area of no bacterial growth around the discs could be seen.

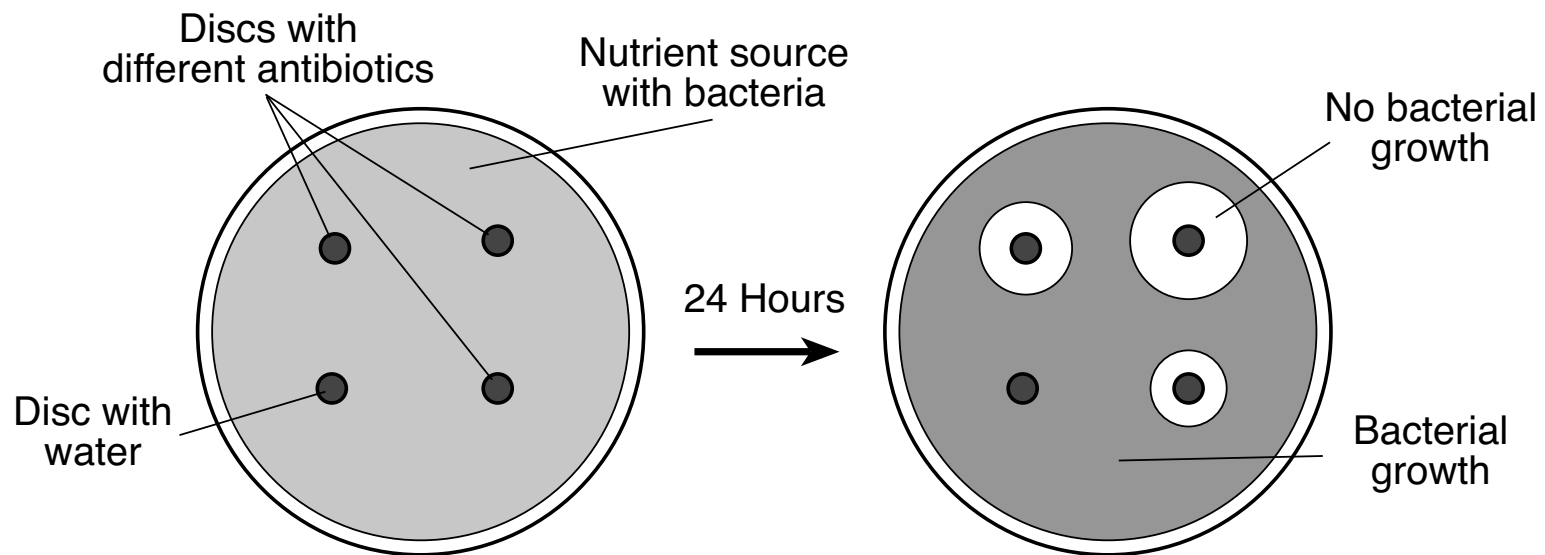

- 34 After 24 hours, the results represented by the diagram demonstrate
- (1) which of these antibiotics most effectively stopped bacterial growth
 - (2) the nutrient source that resulted in the most bacterial growth
 - (3) whether the bacteria were resistant to most antibiotics or not
 - (4) that these bacteria were harmful to antibiotics

35 In this experiment, the purpose of using a disc treated with water is that it

- (1) serves as the conclusion for the experiment
 - (2) is needed to provide additional moisture
 - (3) serves as a control for the experiment
 - (4) is needed as a standard safety procedure
-

36 The diagram below represents some stages in the process of development.

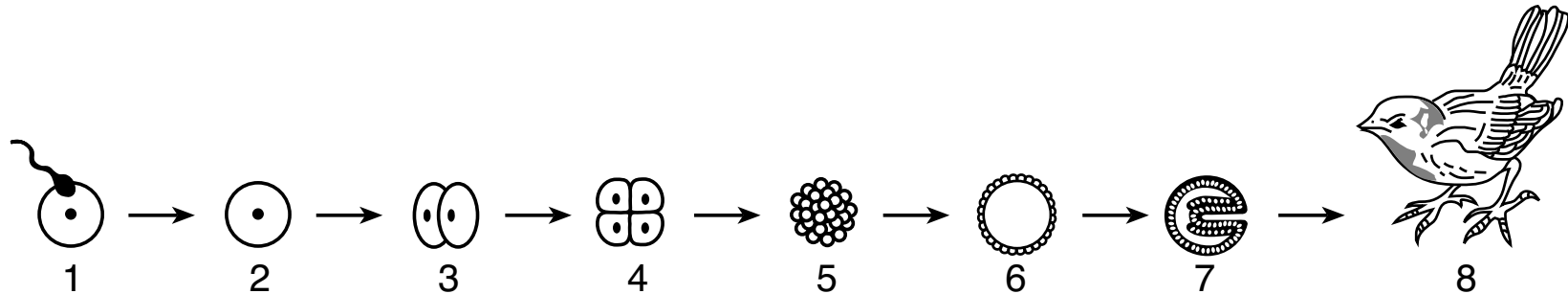

Stage 2 represents a cell that

- (1) contains half the genetic material of an adult cell
- (2) shows clear evidence of tissue differentiation
- (3) has the complete genetic information to form an adult
- (4) is genetically identical to one of the parents that produced it

37 The table below shows the results of a study on the lifespan of 115 individual song sparrows.

Song Sparrow Lifespan

Year	Number at Start of Year	Number at End of Year
1	115	25
2	25	19
3	19	12
4	12	2
5	2	1
6	1	0

The two most likely factors contributing to the decline in the number of these 115 sparrows during year 1 were

- (1) favorable climate and a rapid reproduction rate
- (2) lack of predators and an expanding habitat
- (3) lack of mating and loss of nesting sites
- (4) disease and predation

38 The diagnostic test for HIV, the virus that causes AIDS, involves testing the blood for antibodies associated with this pathogen. Antibodies are produced when the body

- (1) stimulates enzyme production
- (2) secretes specific hormones
- (3) detects foreign antigens
- (4) synthesizes microbes

39 Body cells include nerve cells and muscle cells. Each makes a number of different proteins. For example, nerve cells make cholinesterase and muscle cells make myosin. Which statement best compares the DNA normally found in these two types of cells in an individual?

- (1) The two cells have identical DNA sequences and use the same section of the DNA to make these two proteins.
- (2) The two cells have identical DNA sequences, but use different sections of the DNA to make these two proteins.
- (3) The two cells have different DNA sequences, but use the same section of the DNA to make these two proteins.
- (4) The two cells have different DNA sequences and use different sections of the DNA to make these two proteins.

40 The chart below compares the greenhouse gas emissions of several fuel sources.

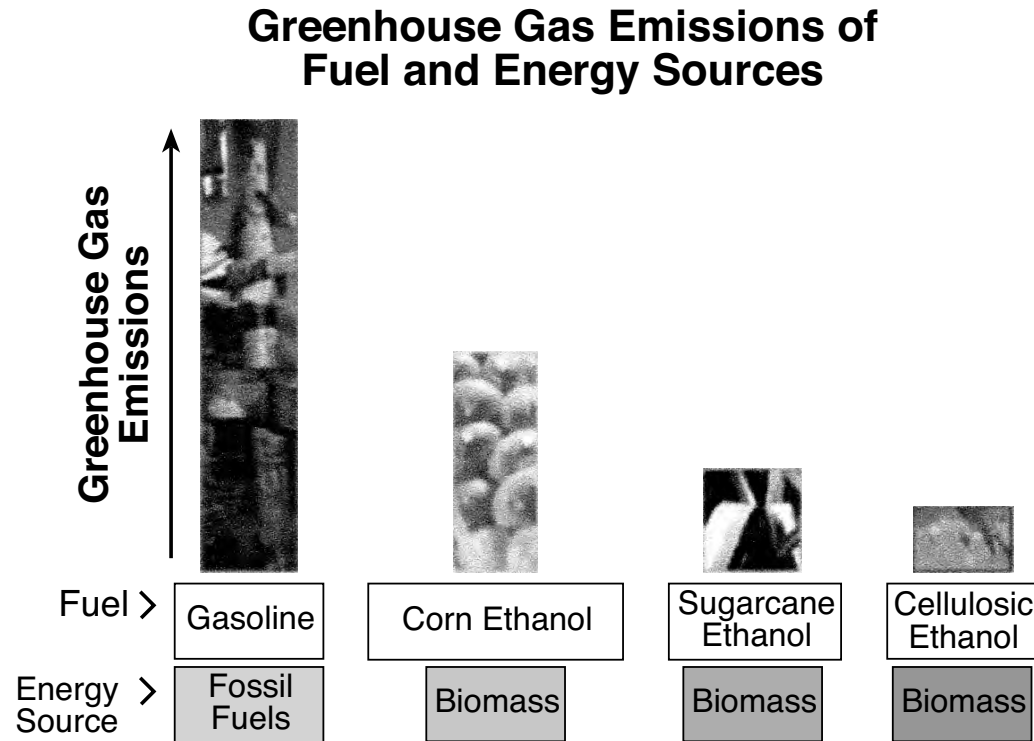

Source: Adapted from <http://energy.itgoverns.com>

An accurate prediction that could be made regarding the information shown in the chart is that

- (1) a total change from gasoline to ethanol as a fuel would have no effect on greenhouse gas emissions
- (2) fossil fuels emit the least amount of greenhouse gases
- (3) the use of any one of the ethanol sources for fuel will each produce less greenhouse gases than the use of gasoline for fuel
- (4) the use of biomass-based fuels instead of fossil fuels will greatly increase the production of greenhouse gases

41 Studies have shown that children are especially vulnerable to the effects of ultraviolet (UV) radiation. Tanning beds expose the skin to nearly ten times as much UV radiation as natural sunlight. With that knowledge, a law was passed in New York State to prevent individuals under the age of 18 from using tanning beds. Which statement best explains why UV radiation is so harmful?

- (1) Certain environmental factors can increase the occurrence of harmful gene mutations.
- (2) Diseases are all caused by exposure to environmental factors.
- (3) Homeostasis in an organism is increased by the presence of radiation.
- (4) Radiation decreases the likelihood that infectious agents cause mutations.

GO RIGHT ON TO THE NEXT PAGE ⇨

Base your answers to questions 42 and 43 on the diagram below and on your knowledge of biology. The diagram shows a small segment of DNA taken from a gene before and after it is copied.

Changes made during the copying process are represented by * in the diagram.

Before	→	After
GTC CAT CAC CGG TAG TCG		GTC CAT [*] GAC CGG TAG TCC [*]

42 The errors indicated by * could affect a cell by

- (1) altering the number of chromosomes present in the cytoplasm
- (2) converting the original cell into a different type of cell
- (3) converting sugar molecules into molecules of protein
- (4) changing the sequence of amino acids during the formation of a specific protein

43 The process by which a cell copies its DNA before it divides is

- | | |
|---------------|-----------------|
| (1) mutation | (3) replication |
| (2) diffusion | (4) respiration |
-

Part B–2

Answer all questions in this part. [12]

Directions (44–55): For those questions that are multiple choice, record on the separate answer sheet the *number* of the choice that, of those given, best completes each statement or answers each question. For all other questions in this part, follow the directions given and record your answers in the spaces provided in this examination booklet.

Base your answers to questions 44 through 47 on the information and data table below and on your knowledge of biology.

Invasive species have damaged agricultural crops all over the world. One study, completed in Japan, calculated the number of invasive insect species present in Japan from 1880 to 1990. Some of the data are recorded in the table below.

Number of Invasive Insect Species per Decade

Year	Number of Invasive Insect Species
1880	3
1900	3
1920	7
1940	10
1960	13
1980	41
1990	25

Adapted from “*Invasive Insect Pests and Plant Quarantine.*” 1998

Directions (44–46): Using the information in the data table, construct a line graph on the grid provided, following the directions below.

44 Mark an appropriate scale, without any breaks in the data, on each labeled axis. [1]

45 Plot the data on the grid. Connect the points and surround each point with a small circle. [1]

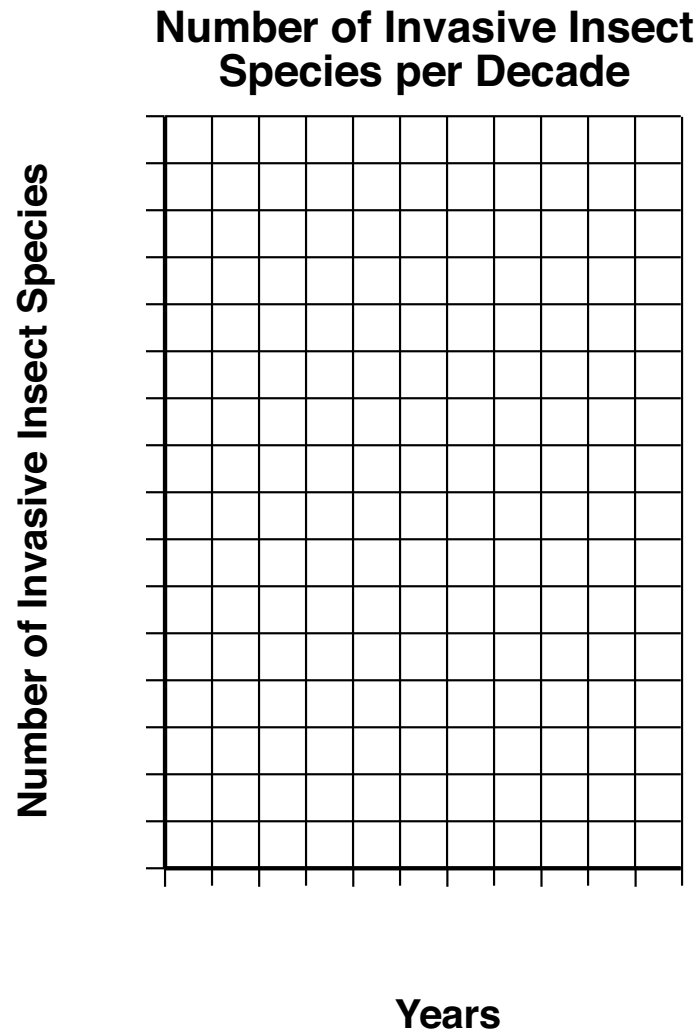
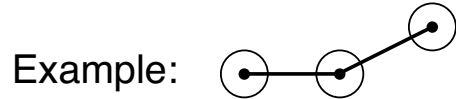

46 State *one* reason why invasive insect species are a major problem for agriculture. [1]

Note: The answer to question 47 should be recorded on your separate answer sheet.

- 47 In the last decade of this study, there was a decrease in the number of invasive insects that entered Japan. One likely reason for this decrease is that people have
- (1) produced insecticides that are strong enough to kill every insect that is present in crops going from one country to another
 - (2) improved inspections of crops that are transported from one area of the world to another area of the world
 - (3) genetically altered all insects so they don't feed on crops that humans use
 - (4) stopped the transportation of all food crops from other countries, requiring each area to use only locally grown crops
-

48 A double-stranded DNA sample was analyzed to establish the percentage of different molecular bases present. The data table below shows the percentage of adenine bases found. Calculate the percentage of each of the three remaining molecular bases, and write the percentages of each in the chart. [1]

Base	Percent Found (%)
A (Adenine)	20
T (Thymine)	_____
G (Guanine)	_____
C (Cytosine)	_____

GO RIGHT ON TO THE NEXT PAGE ⇨

Base your answers to questions 49 and 50 on the information and diagram below and on your knowledge of biology.

An investigation was conducted to compare two different types of plants. A student used a microscope to observe the cells in a cross section of a lilac leaf (diagram A) and a cell from the leaf of a freshwater plant (diagram B).

Diagram A

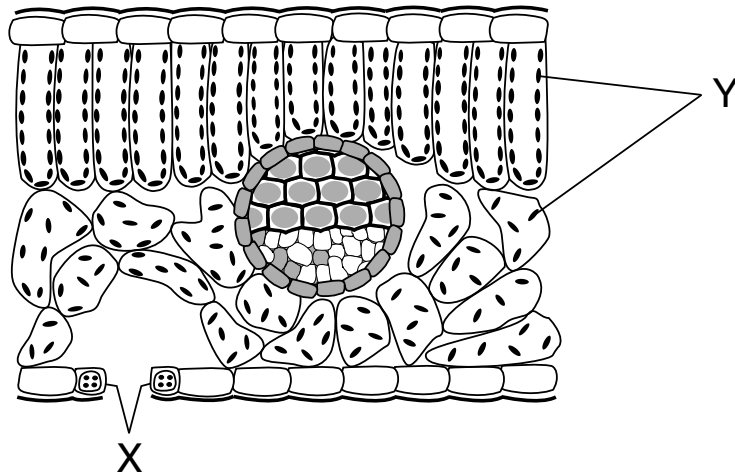
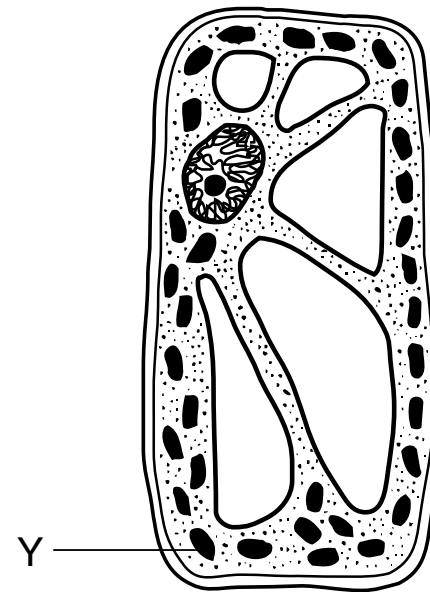

Diagram B



(Not drawn to scale)

Note: The answer to question 49 should be recorded on your separate answer sheet.

49 Which row in the chart below correctly identifies the structure labeled Y in both diagrams and the process it performs?

Row	Structure	Process
(1)	mitochondrion	excretion
(2)	nucleus	regulation
(3)	chloroplast	photosynthesis
(4)	ribosome	protein synthesis

Note: The answer to question 50 should be recorded on your separate answer sheet.

50 Which technique could be used to make the structures in the cells more visible when using a compound light microscope?

(1) paper chromatography

(3) electrophoresis

(2) staining

(4) gene manipulation

Base your answers to questions 51 through 54 on the information and photograph below and on your knowledge of biology.

Transgenic (GMO) Tomatoes

The use of pesticides to control insects costs billions of dollars every year. Genetically modified organisms (GMOs) are an attempt to reduce this cost. Tomato plants that are genetically modified can make proteins that are poisonous to the insects that feed on them. Using these GMO tomatoes would reduce the need for the chemical control of insects.

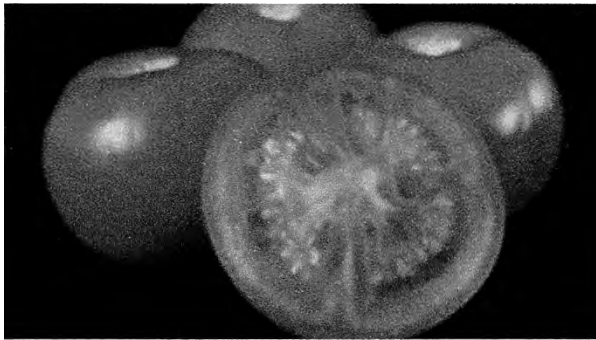

Source: www.southeastfarmpress.com

51 Identify a specific technique used to produce the GMO tomatoes. [1]

52 State *one* possible advantage of having tomato plants that make proteins that are poisonous to insects. [1]

53 Identify the type of chemical substance a scientist would need to use to cut and paste the genes to produce genetically modified tomato plants. [1]

54 Identify the process responsible for passing the gene for insect resistance in a leaf cell of a genetically modified tomato plant on to the cells that develop from it. [1]

55 The diagram below represents the human female reproductive system.

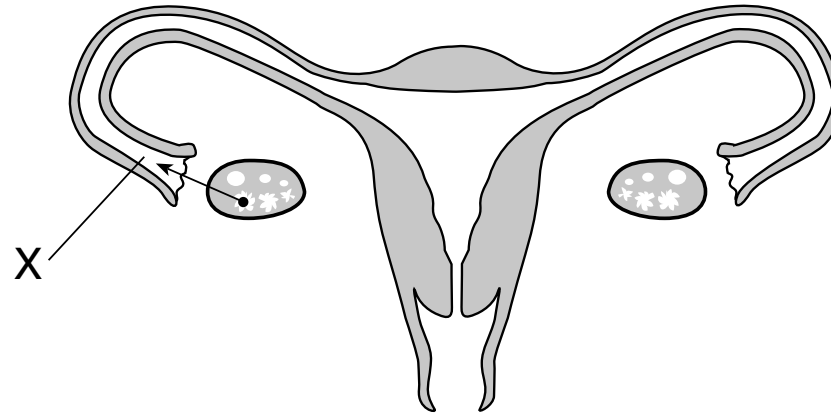

State *one* way a complete blockage at location *X* would affect the reproductive process. [1]

Part C

Answer all questions in this part. [17]

Directions (56–72): Record your answers in the spaces provided in this examination booklet.

GO RIGHT ON TO THE NEXT PAGE ⇨

Base your answers to questions 56 through 58 on the food web represented below and on your knowledge of biology. The food web contains some of the organisms found in Glacier National Park.

Glacier National Park Food Web

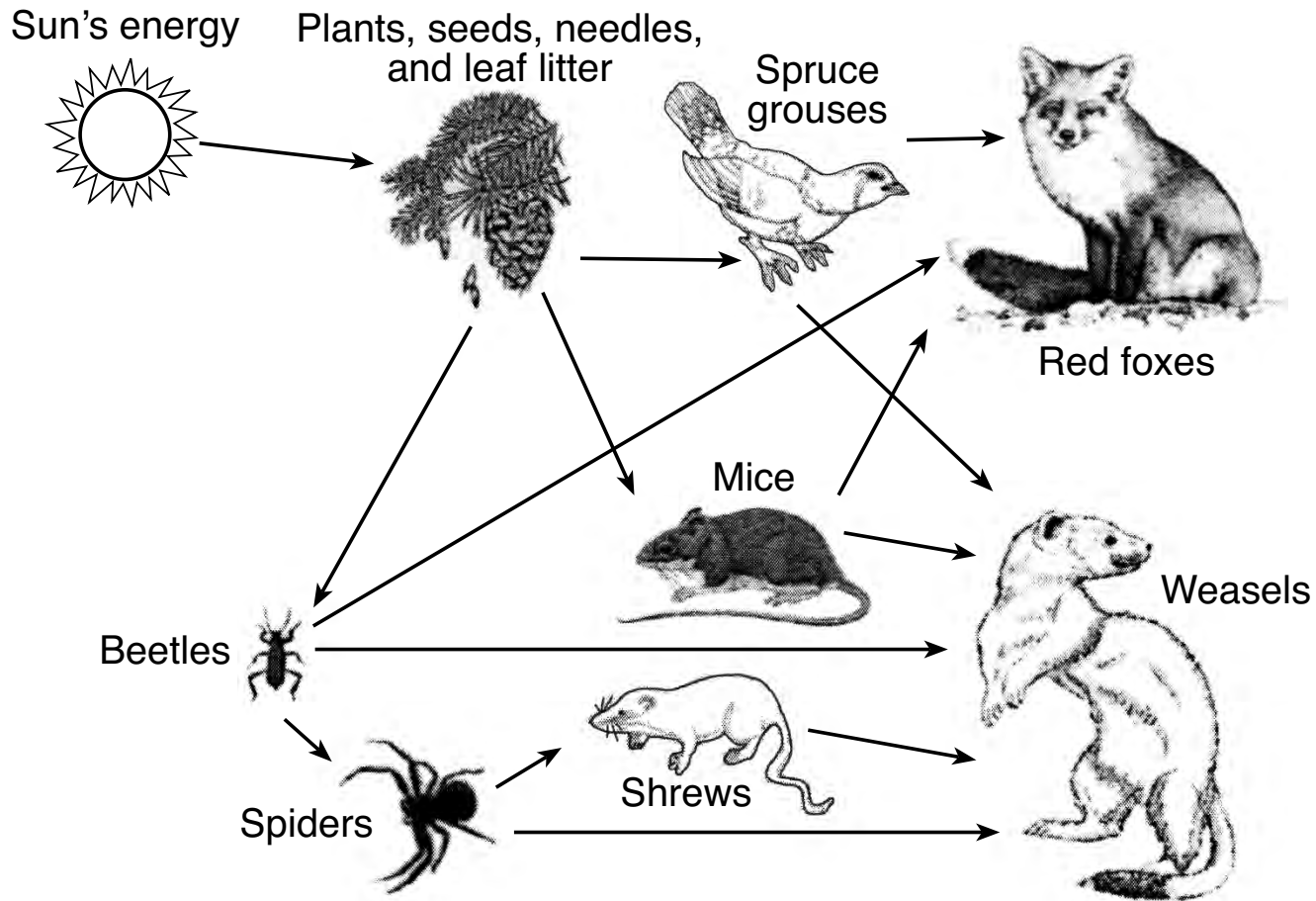

Source: www.nps.gov

56 Identify which group of organisms in this food web would contain the greatest amount of stored energy. Support your answer. [1]

Organisms: _____

Support: _____

57 Explain why a major increase in the number of cloudy days that extends over a period of years would be expected to affect the populations of both plants and animals in this ecosystem. [1]

58 Describe how the niche of the mouse population differs from the niche of the shrew population in this ecosystem. Support your answer with information from the food web. [1]

Base your answers to questions 59 through 61 on the diagram below and on your knowledge of biology. The diagram represents a human enzyme.

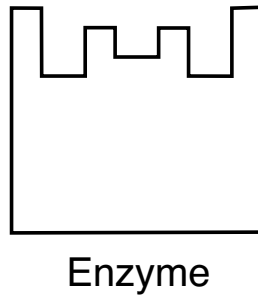

59 In the space below, draw a molecule that would most likely be able to interact with this enzyme. [1]

60 Describe *one* role of enzymes in the human body. [1]

61 A person has a high fever of 105°F. State *one* effect that this high fever would likely have on enzyme activity. [1]

Base your answers to questions 62 through 64 on the information and graph below and on your knowledge of biology.

Dr. Liz Hadly studied the ecology of Yellowstone National Park for 30 years, specifically the amphibians inhabiting the park for 20 of those years. Dr. Hadly studied 46 ponds in 1992-1993. Of these, 43 supported amphibians. From 2006-2008, only 38 of the original 46 ponds contained water. The graph below represents population data for four amphibian species collected by Dr. Hadly during 1992-1993 and 2006-2008.

Changes in Four Yellowstone Amphibian Populations

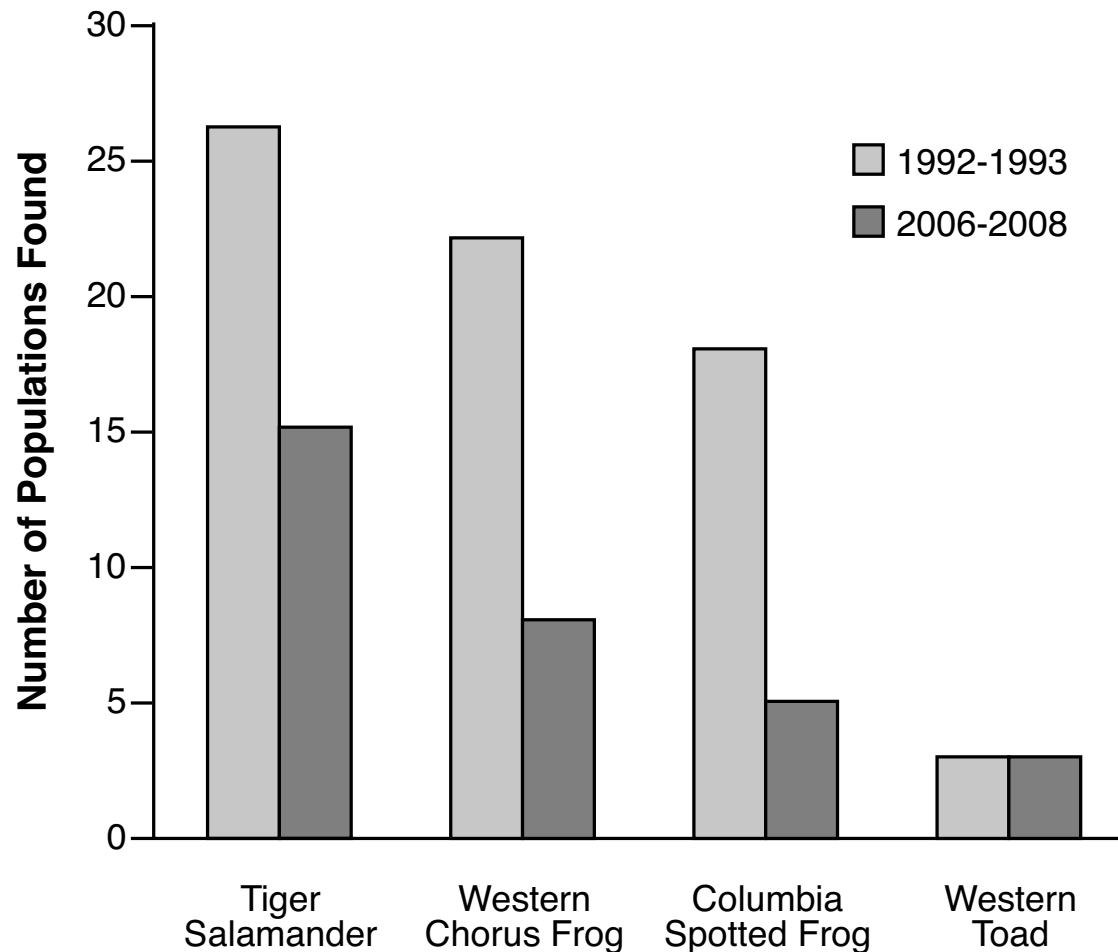

Source: Proceedings of NAS 105(44), 16988 -16993

62 Explain why such a long-term study is more likely to be accepted by Dr. Hadly's peers than one that took place over a shorter period of time. [1]

63 Describe the trend in the amphibian populations over the course of the study. Support your answer with information from the graph. [1]

64 Explain how global warming could have affected Yellowstone frog and salamander habitats, resulting in changes in the populations of these species. [1]

Base your answer to question 65–67 on the information below and on your knowledge of biology.

Information From the Cat Gene Database

A database is being used to trace the evolutionary history of wild and domestic cats. Comparisons show that there are very few differences between the genes present in domestic cats and the genes present in wild cats, such as tigers and lions. Research has also shown that wild cats and domestic cats last shared a common ancestor about 11 million years ago. Since then, there has been very little change in the entire cat genome (the complete set of genes for all the species). This indicates that the cats are well-adapted to change. Yet, there are some important differences.

Big cats share about 1,376 genes that set them apart from other animals. These genes are related to muscle strength and the ability to digest protein. In addition, there are genes that have been found in specific cats that live in specific environments. Genes related to smell, visual perception, and nerve development are evolving rapidly in Siberian tigers. Snow leopards have three mutations related to the use of oxygen at high altitudes. The database is also being used to study diversity within various cat species.

- 65–67 Discuss the importance of establishing a genome database for a cat species. In your answer, be sure to:
- state *one* example of a genetic variation that is important for the survival of *one* specific cat species [1]
 - identify a specific technique that can be used to analyze the genomes of organisms and explain how the results are used [1]
 - explain how genes for a trait, such as a specific fur color, can increase in frequency in a population over time [1]

Base your answers to questions 68 through 70 on the passage below and on your knowledge of biology.

Here, Eat This Vaccine

Munching on bacteria could be a good way to stimulate your immune system. Biologist Simon Cutting of the Royal Holloway University of London has transformed bacterial spores into an edible vaccine. He and his collaborators genetically altered the common bacterium *Bacillus subtilis* so that it produced harmless fragments of the toxin produced by tetanus. Then his team starved the bacterium so that it turned into a spore — a desiccated [dehydrated] packet tough enough to survive a trip through the digestive tract and into the bloodstream. Most of the mice that inhaled or ate the modified spores were then able to survive a lethal dose of tetanus.

“We selected tetanus because the immunology regarding this disease is well understood,” Cutting says. But engineered bacteria could be similarly tailored to train the immune system to fight anthrax, traveler’s diarrhea, and other illnesses. Edible vaccines would eliminate the need for needles and sterilizing equipment. Moreover, spores can withstand extreme heat and dryness, remaining viable [alive] for thousands of years. Cutting plans to start clinical trials in about two years. If the results measure up, spore vaccines could slash the cost of immunization programs, especially in poor countries where refrigeration is unreliable and transportation can be slow.

Source: <http://discovermagazine.com/2003/aug/breakeat/>
Here, Eat This Vaccine, by Zara Herskovits August 1, 2003

68 Describe *one* way the immune system could respond when it is exposed to the genetically altered *Bacillus subtilis*. [1]

69 Will individuals who have taken the vaccine be protected against future tetanus infections? Support your answer. [1]

70 State *one* advantage of using edible modified spores as vaccines. [1]

Base your answers to questions 71 and 72 on the information below and on your knowledge of biology.

Reproductive Adaptations of Mammals

Mammals have unique reproductive adaptations that have contributed to their evolutionary success. One of the distinguishing characteristics of mammals is their mammary glands, which allow for the production of milk. Even the more primitive mammals, such as the duck-billed platypus and the kangaroo, have some type of mammary glands. However, only the placental mammals (e.g. humans, horses, dogs) have a placenta, which supports the internal development of the embryo. The most primitive mammals have no placenta and can't support the internal development of the embryo.

71 Explain how the mammary glands contribute to the reproductive success of mammals. [1]

72 Describe *one* function of the placenta found in mammals such as humans, horses, and dogs. [1]

GO RIGHT ON TO THE NEXT PAGE ⇨

Part D

Answer all questions in this part. [13]

Directions (73–85): For those questions that are multiple choice, record on the separate answer sheet the *number* of the choice that, of those given, best completes each statement or answers each question. For all other questions in this part, follow the directions given and record your answers in the spaces provided in this examination booklet.

Note: The answer to question 73 should be recorded on your separate answer sheet.

73 A procedure used in paper chromatography is represented below:

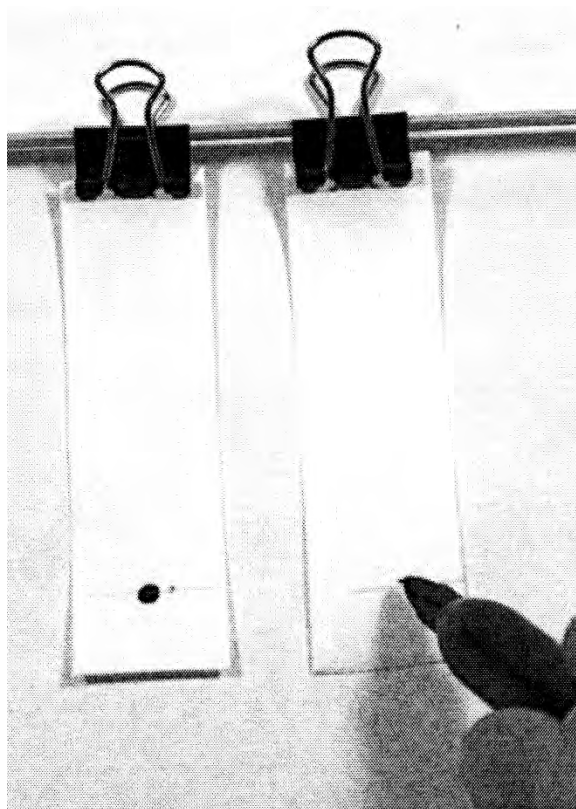

Source: [www.sciencebuddies.org/
sciencefair](http://www.sciencebuddies.org/sciencefair)

The student is preparing two strips of paper for a chromatography activity. After adding a dot of the ink from the marker pen to the line on the paper on the right, the next step should be to place the strips in a beaker of solvent with the solvent level

- (1) between the bottom of the paper and the dot of ink
- (2) even with the dot of ink on the paper
- (3) just below the bottom edge of the paper
- (4) slightly above the dot of ink on the paper

GO RIGHT ON TO THE NEXT PAGE ⇨

Note: The answer to question 74 should be recorded on your separate answer sheet.

Base your answer to question 74 on the information below and on your knowledge of biology.

Some students tested two samples of a mixture of starch and water with two different indicators. The results of these tests are shown in Table 1 below.

Table 1: Results of Testing a Starch-Water Solution with Indicators.			
Indicator Used	Color of Indicator Alone	Sample Being Tested	Color of Sample After Indicator Was Added
starch indicator	amber	starch and water	black
glucose indicator + heat	blue	starch and water	blue

Next, a specific protein was added to two new samples of the starch and water mixture. After waiting 30 minutes, the students tested these samples with the same two indicator solutions. The results are shown in Table 2 below.

Table 2: Results of Testing a Starch-Water Solution with Indicators 30 Minutes After Adding a Certain Protein			
Indicator Used	Color of Indicator Alone	Sample Being Tested	Color of Sample After Indicator Was Added
starch indicator	amber	starch and water	amber
glucose indicator + heat	blue	starch and water	brick red

- 74 Based on these results, it can be concluded that the specific protein that was added to the samples was
- (1) a salt solution
 - (2) a new indicator
 - (3) a pancreatic hormone
 - (4) a biological catalyst
-

GO RIGHT ON TO THE NEXT PAGE ⇨

Base your answers to questions 75 and 76 on the information and diagram below and on your knowledge of biology. The diagram represents red blood cells placed in three test tubes, each containing a different salt solution.

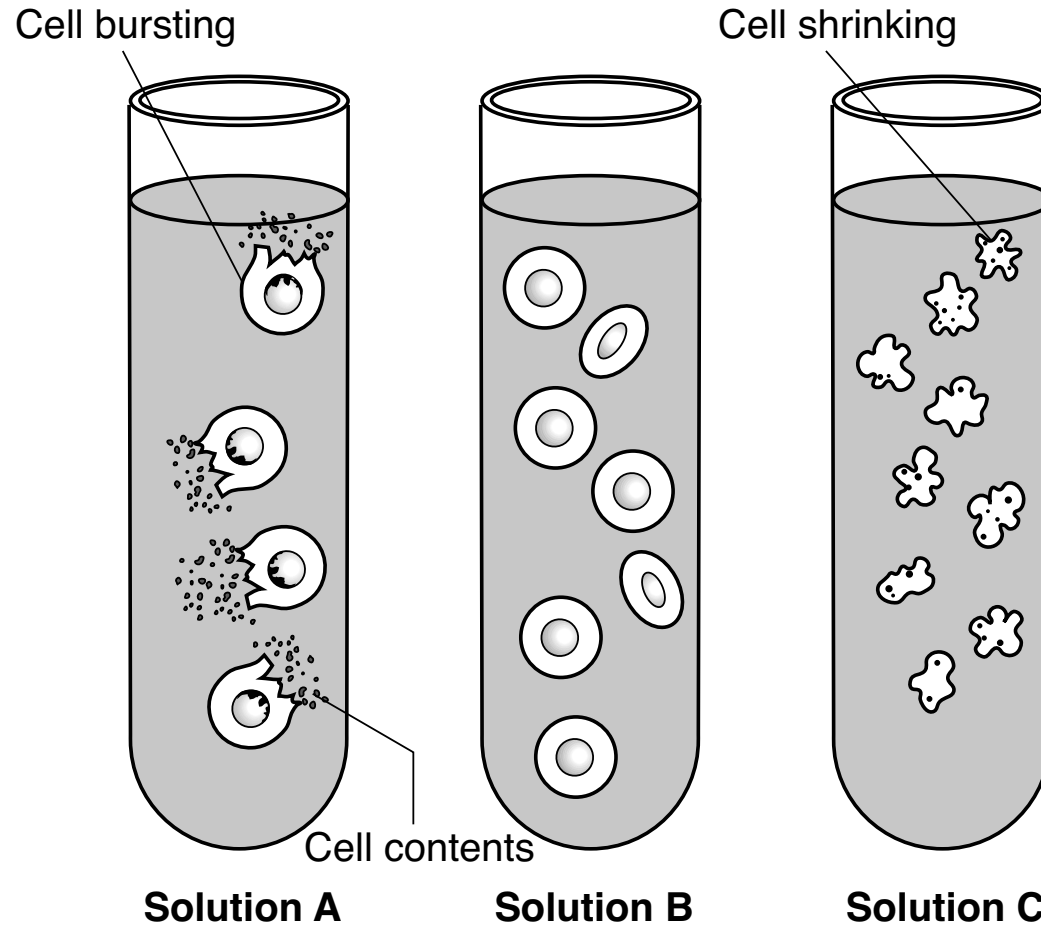

Source: users.rcn.com

Note: The answer to question 75 should be recorded on your separate answer sheet.

75 Which statement best describes solution *C*?

- (1) The concentration of dissolved salt in the solution is greater than the concentration in the cells.
- (2) The concentration of dissolved salt in the solution is less than the concentration in the cells.
- (3) The concentration of water in the solution is greater than the concentration in the cells.
- (4) The concentration of water in the solution is equal to the concentration in the cells.

Note: The answer to question 76 should be recorded on your separate answer sheet.

76 Which solution would be most similar in concentration to the normal internal environment of the human circulatory system?

- (1) solution *A*, only
 - (2) solution *B*, only
 - (3) solutions *A* and *B*
 - (4) solutions *A* and *C*
-

Base your answers to questions 77 and 78 on the information and graph below and on your knowledge of biology.

A species of bird lives on an island. Beak thickness varies within the population. The birds feed mainly on seeds. Birds with smaller beaks can eat only small seeds. Only birds with larger beaks are able to crush and eat large seeds.

During years with more rain, small seeds are abundant. During dry years, there are very few small seeds, but there are many large seeds.

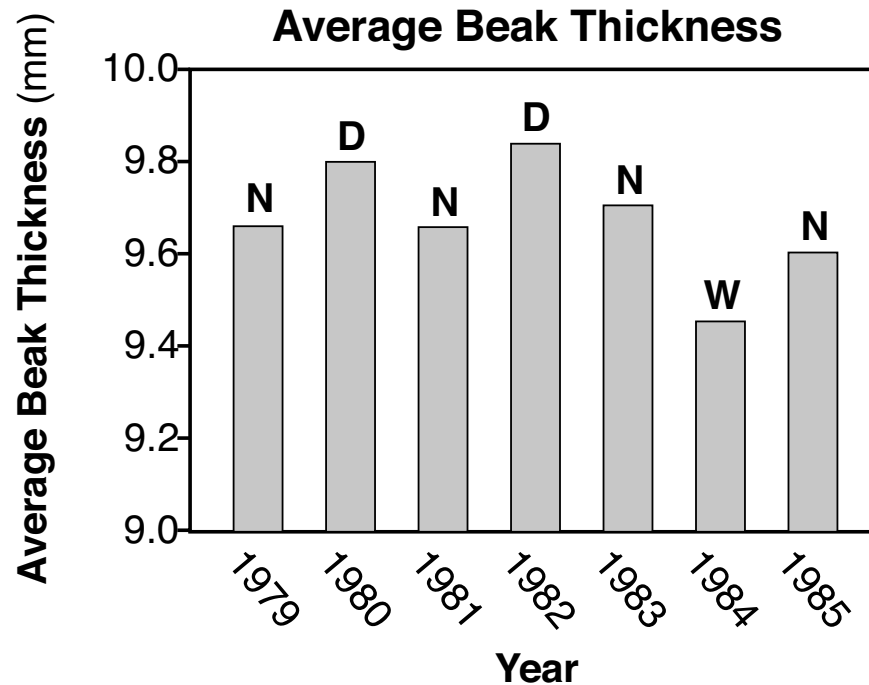

Key
N = year with normal rainfall
W = year with above-normal rainfall (wet)
D = year with below-normal rainfall (dry)

Source: mdk12.org/assessments

77 Predict how the average beak thickness would be expected to change after 1985 if there were eight very dry years in a row. Support your answer. [1]

78 State *one* specific advantage for this bird species to have members of this population with beaks that range from approximately 9.4 mm to 9.9 mm in thickness. [1]

79 Identify *one* biotic factor that can affect the survival of a finch population in the Galapagos Islands. [1]

80 During a laboratory activity, students ran in place for three minutes. Students then complained of muscle fatigue in their legs. State *one* biological reason why the students experienced muscle fatigue after exercising. [1]

Note: The answer to question 81 should be recorded on your separate answer sheet.

81 A student is viewing a plant stem cross section using a compound light microscope.

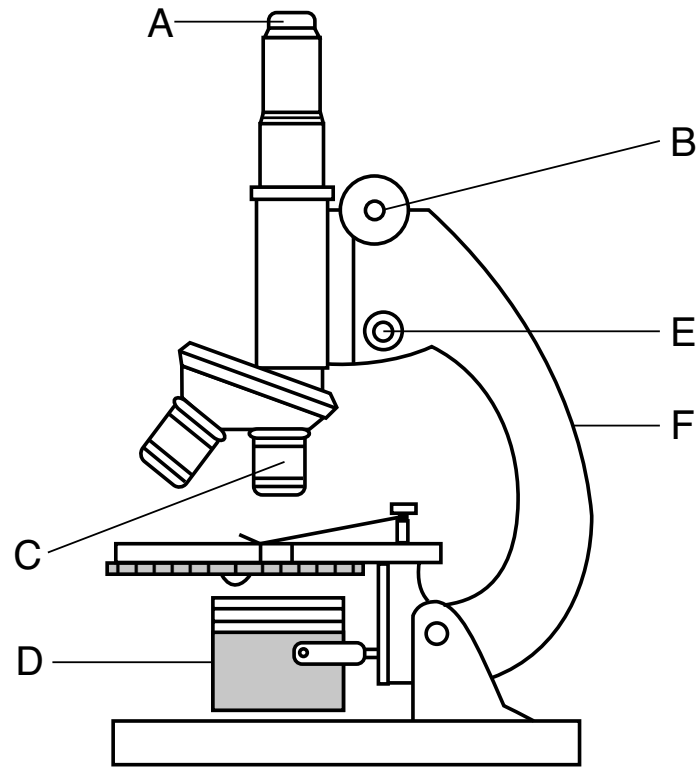

What parts of the microscope should the student use to bring the image into focus?

(1) *A* and *F*

(2) *B* and *E*

(3) *C* and *D*

(4) *D* and *F*

Note: The answer to question 82 should be recorded on your separate answer sheet.

82 A rare tropical plant was found to have medicinal properties. A search was conducted to find other plants that are closely related to the rare plant. Which combination of characteristics would best identify the plant most closely related to the original one?

- (1) shape of seeds, number of flower petals, leaf pigments
- (2) number of flower petals, positive reaction to a specific enzyme
- (3) leaf pigments, sequence of DNA bases, positive reaction to a specific enzyme
- (4) presence of DNA bases, internal stem structure, shape of seeds

83 The diagram below represents three branching diagrams that show relationships between three different species, X, Y, and Z.

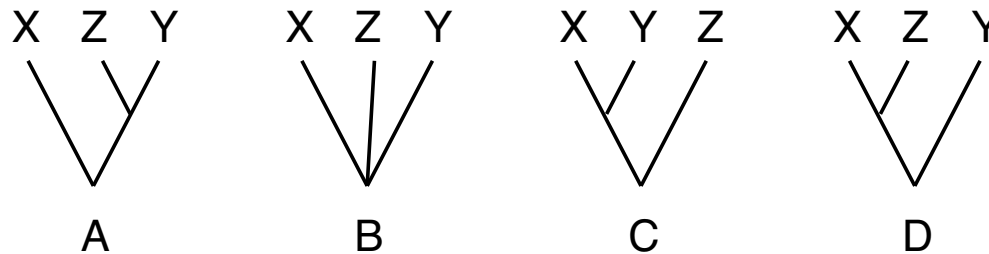

On the line below, write the letter of the diagram that shows that X and Y are more closely related to each other than to species Z. Explain why that diagram indicates a close relationship. [1]

Diagram: _____

Explanation: _____

Base your answer to question 84 on the information below and on your knowledge of biology.

Anoles are a diverse group of lizards that live on several islands including Cuba, Hispaniola, Jamaica, and Puerto Rico. Large populations of several species exist on these islands. The preferred region of the tree inhabited by the six species of anole lizards is represented in the diagram below.

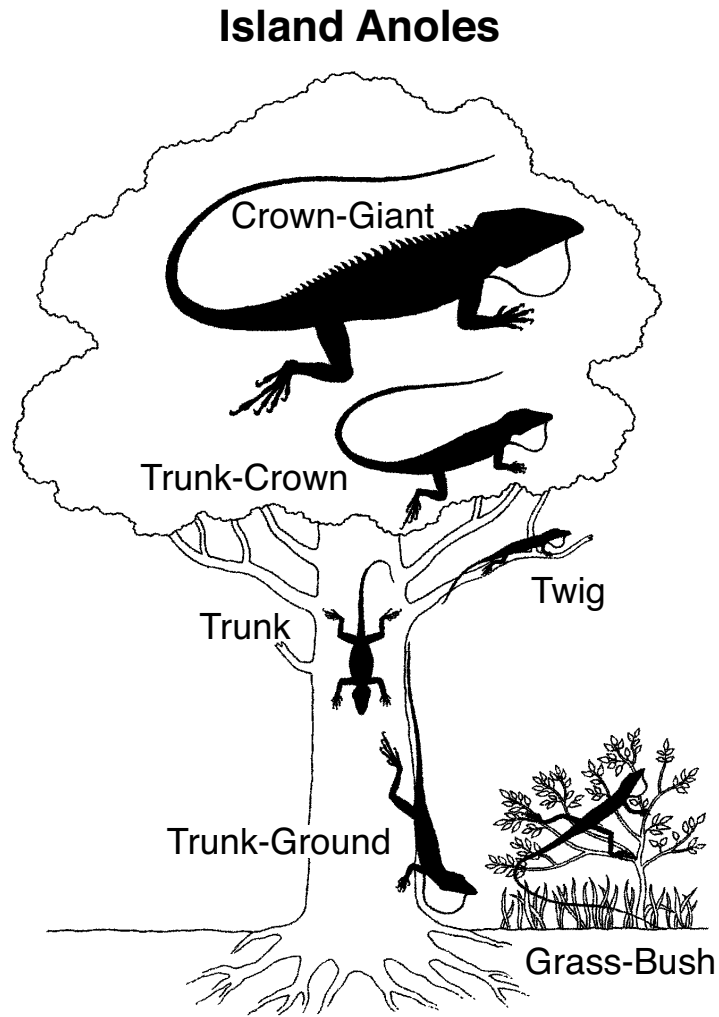

Source: Adapted from Losos, jb, 2010

84 Would you expect the crown-giant and trunk-ground anoles to compete for resources if they lived on the same tree? Circle yes *or* no and support your answer with an explanation. [1]

Circle one: Yes *or* No

Explanation: _____

Base your answer to question 85 on the information below and on your knowledge of biology.

A class carried out an experiment to test the effect of rest time after exercise on the breathing rate. Each member of the class ran up and down stairs for 60 seconds. After exercising, they rested. The students then measured their rate of respiration by counting the number of inhales and exhales per minute for 7 minutes. The class then averaged their data.

85 Provide a biological explanation for why the breathing rate *decreases* several minutes after physical activity has stopped. [1]

