

The University of the State of New York  
REGENTS HIGH SCHOOL EXAMINATION

**PHYSICAL SETTING**  
**PHYSICS**

**Thursday, January 25, 2007 — 1:15 to 4:15 p.m., only**

The answer sheet for Part A and Part B–1 is the last page of this examination booklet. Turn to the last page and fold it along the perforations. Then, slowly and carefully, tear off the answer sheet and fill in the heading.

The answer booklet for Part B–2 and Part C is stapled in the center of this examination booklet. Open the examination booklet, carefully remove the answer booklet, and close the examination booklet. Then fill in the heading of your answer booklet.

You are to answer *all* questions in all parts of this examination according to the directions provided in the examination booklet. Record your answers to the Part A and Part B–1 multiple-choice questions on your separate answer sheet. Write your answers to the Part B–2 and Part C questions in your answer booklet. All work should be written in pen, except for graphs and drawings, which should be done in pencil. You may use scrap paper to work out the answers to the questions, but be sure to record all your answers on the answer sheet and in the answer booklet.

When you have completed the examination, you must sign the statement printed at the end of your separate answer sheet, indicating that you had no unlawful knowledge of the questions or answers prior to the examination and that you have neither given nor received assistance in answering any of the questions during the examination. Your answer sheet and answer booklet cannot be accepted if you fail to sign this declaration.

Notice . . .

A scientific or graphing calculator, a centimeter ruler, a protractor, and a copy of the *2006 Edition Reference Tables for Physical Setting/Physics*, which you may need to answer some questions in this examination, must be available for your use while taking this examination.

The use of any communications device is strictly prohibited when taking this examination. If you use any communications device, no matter how briefly, your examination will be invalidated and no score will be calculated for you.

**DO NOT OPEN THIS EXAMINATION BOOKLET UNTIL THE SIGNAL IS GIVEN.**

## Part A

Answer all questions in this part.

*Directions (1–35):* For each statement or question, write on the separate answer sheet the *number* of the word or expression that, of those given, best completes the statement or answers the question.

1 Which is a vector quantity?

- (1) electric charge
- (2) electric field strength
- (3) electric potential difference
- (4) electric resistance

**Note that question 2 has only three choices.**

2 A 6.0-newton force and an 8.0-newton force act concurrently on a point. As the angle between these forces increases from  $0^\circ$  to  $90^\circ$ , the magnitude of their resultant

- (1) decreases
- (2) increases
- (3) remains the same

3 A car increases its speed from 9.6 meters per second to 11.2 meters per second in 4.0 seconds. The average acceleration of the car during this 4.0-second interval is

- (1)  $0.40 \text{ m/s}^2$
- (2)  $2.4 \text{ m/s}^2$
- (3)  $2.8 \text{ m/s}^2$
- (4)  $5.2 \text{ m/s}^2$

4 What is the speed of a 2.5-kilogram mass after it has fallen freely from rest through a distance of 12 meters?

- (1) 4.8 m/s
- (2) 15 m/s
- (3) 30. m/s
- (4) 43 m/s

5 A machine launches a tennis ball at an angle of  $25^\circ$  above the horizontal at a speed of 14 meters per second. The ball returns to level ground. Which combination of changes *must* produce an increase in time of flight of a second launch?

- (1) decrease the launch angle and decrease the ball's initial speed
- (2) decrease the launch angle and increase the ball's initial speed
- (3) increase the launch angle and decrease the ball's initial speed
- (4) increase the launch angle and increase the ball's initial speed

6 A ball attached to a string is moved at constant speed in a horizontal circular path. A target is located near the path of the ball as shown in the diagram.

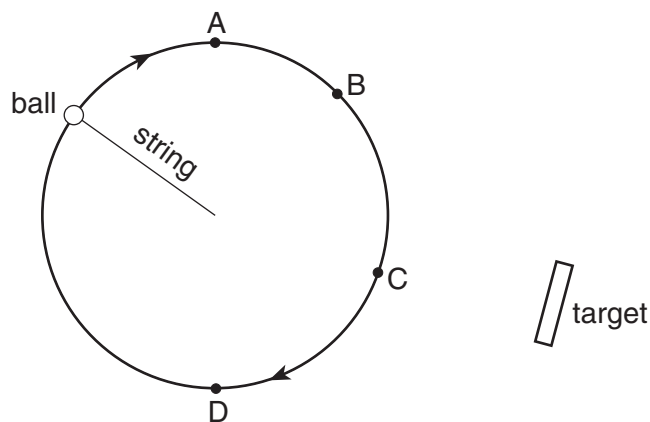

At which point along the ball's path should the string be released, if the ball is to hit the target?

- (1) A
- (2) B
- (3) C
- (4) D

7 A plane flying horizontally above Earth's surface at 100. meters per second drops a crate. The crate strikes the ground 30.0 seconds later. What is the magnitude of the horizontal component of the crate's velocity just before it strikes the ground? [Neglect friction.]

- (1) 0 m/s
- (2) 100. m/s
- (3) 294 m/s
- (4) 394 m/s

8 A woman with horizontal velocity  $v_1$  jumps off a dock into a stationary boat. After landing in the boat, the woman and the boat move with velocity  $v_2$ . Compared to velocity  $v_1$ , velocity  $v_2$  has

- (1) the same magnitude and the same direction
- (2) the same magnitude and opposite direction
- (3) smaller magnitude and the same direction
- (4) larger magnitude and the same direction

- 9 Which object has the greatest inertia?
- (1) a 5.0-kg object moving at a speed of 5.0 m/s
  - (2) a 10.-kg object moving at a speed of 3.0 m/s
  - (3) a 15-kg object moving at a speed of 1.0 m/s
  - (4) a 20.-kg object at rest
- 10 As an astronaut travels from the surface of Earth to a position that is four times as far away from the center of Earth, the astronaut's
- (1) mass decreases
  - (2) mass remains the same
  - (3) weight increases
  - (4) weight remains the same
- 11 A 0.15-kilogram baseball moving at 20. meters per second is stopped by a catcher in 0.010 second. The average force stopping the ball is
- (1)  $3.0 \times 10^{-2}$  N
  - (2)  $3.0 \times 10^0$  N
  - (3)  $3.0 \times 10^1$  N
  - (4)  $3.0 \times 10^2$  N
- 12 A spring with a spring constant of 80. newtons per meter is displaced 0.30 meter from its equilibrium position. The potential energy stored in the spring is
- (1) 3.6 J
  - (2) 7.2 J
  - (3) 12 J
  - (4) 24 J
- 13 The work done in accelerating an object along a frictionless horizontal surface is equal to the change in the object's
- (1) momentum
  - (2) velocity
  - (3) potential energy
  - (4) kinetic energy
- 14 As a block slides across a table, its speed decreases while its temperature increases. Which two changes occur in the block's energy as it slides?
- (1) a decrease in kinetic energy and an increase in internal energy
  - (2) an increase in kinetic energy and a decrease in internal energy
  - (3) a decrease in both kinetic energy and internal energy
  - (4) an increase in both kinetic energy and internal energy

- 15 If 60. joules of work is required to move 5.0 coulombs of charge between two points in an electric field, what is the potential difference between these points?
- (1) 5.0 V
  - (2) 12 V
  - (3) 60. V
  - (4) 300 V
- 16 Which statement best describes a proton that is being accelerated?
- (1) It produces electromagnetic radiation.
  - (2) The magnitude of its charge increases.
  - (3) It absorbs a neutron to become an electron.
  - (4) It is attracted to other protons.
- 17 The diagram below represents a simple circuit consisting of a variable resistor, a battery, an ammeter, and a voltmeter.

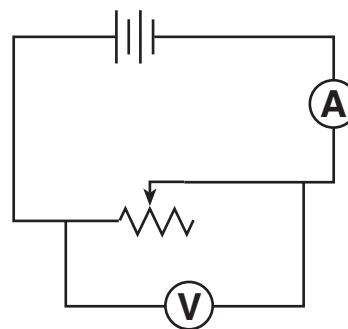

- What is the effect of increasing the resistance of the variable resistor from  $1000 \Omega$  to  $10000 \Omega$ ? [Assume constant temperature.]
- (1) The ammeter reading decreases.
  - (2) The ammeter reading increases.
  - (3) The voltmeter reading decreases.
  - (4) The voltmeter reading increases.
- 18 If the distance separating an electron and a proton is halved, the magnitude of the electrostatic force between these charged particles will be
- (1) unchanged
  - (2) doubled
  - (3) quartered
  - (4) quadrupled

- 19 Two similar metal spheres, *A* and *B*, have charges of  $+2.0 \times 10^{-6}$  coulomb and  $+1.0 \times 10^{-6}$  coulomb, respectively, as shown in the diagram below.

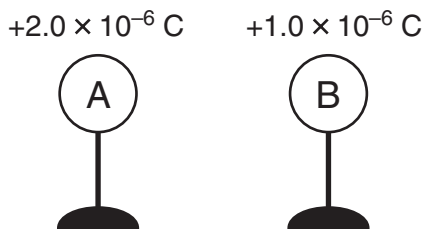

The magnitude of the electrostatic force on *A* due to *B* is 2.4 newtons. What is the magnitude of the electrostatic force on *B* due to *A*?

- (1) 1.2 N                                  (3) 4.8 N  
 (2) 2.4 N                                  (4) 9.6 N
- 20 In the diagram below, *P* is a point near a negatively charged sphere.



Which vector best represents the direction of the electric field at point *P*?

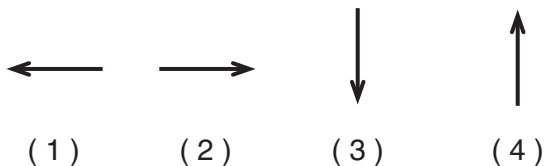

**Note that question 21 has only three choices.**

- 21 If the amplitude of a wave traveling in a rope is doubled, the speed of the wave in the rope will
- (1) decrease  
 (2) increase  
 (3) remain the same
- 22 Two waves having the same amplitude and frequency are traveling in the same medium. Maximum destructive interference will occur when the phase difference between the waves is
- (1)  $0^\circ$                                   (3)  $180^\circ$   
 (2)  $90^\circ$                                   (4)  $270^\circ$

- 23 What is the speed of a radio wave in a vacuum?
- (1) 0 m/s                                  (3)  $1.13 \times 10^3$  m/s  
 (2)  $3.31 \times 10^2$  m/s                  (4)  $3.00 \times 10^8$  m/s

- 24 A ringing bell is located in a chamber. When the air is removed from the chamber, why can the bell be seen vibrating but *not* be heard?
- (1) Light waves can travel through a vacuum, but sound waves cannot.  
 (2) Sound waves have greater amplitude than light waves.  
 (3) Light waves travel slower than sound waves.  
 (4) Sound waves have higher frequency than light waves.

- 25 As a transverse wave travels through a medium, the individual particles of the medium move
- (1) perpendicular to the direction of wave travel  
 (2) parallel to the direction of wave travel  
 (3) in circles  
 (4) in ellipses

- 26 A straight glass rod appears to bend when placed in a beaker of water, as shown in the diagram below.

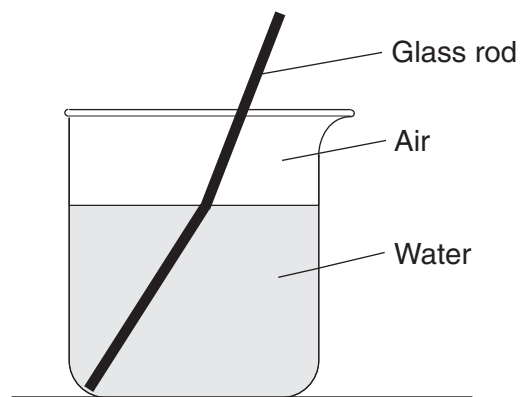

What is the best explanation for this phenomenon?

- (1) The water is warmer than the air.  
 (2) Light travels faster in water than in air.  
 (3) Light is reflected at the air-water interface.  
 (4) Light is refracted as it crosses the air-water interface.

- 27 What happens to the speed and frequency of a light ray when it passes from air into water?
- (1) The speed decreases and the frequency increases.
  - (2) The speed decreases and the frequency remains the same.
  - (3) The speed increases and the frequency increases.
  - (4) The speed increases and the frequency remains the same.
- 28 Parallel wave fronts incident on an opening in a barrier are diffracted. For which combination of wavelength and size of opening will diffraction effects be greatest?
- (1) short wavelength and narrow opening
  - (2) short wavelength and wide opening
  - (3) long wavelength and narrow opening
  - (4) long wavelength and wide opening
- 29 Which wave phenomenon occurs when vibrations in one object cause vibrations in a second object?
- (1) reflection
  - (2) resonance
  - (3) intensity
  - (4) tuning
- 30 A photon having an energy of 9.40 electronvolts strikes a hydrogen atom in the ground state. Why is the photon *not* absorbed by the hydrogen atom?
- (1) The atom's orbital electron is moving too fast.
  - (2) The photon striking the atom is moving too fast.
  - (3) The photon's energy is too small.
  - (4) The photon is being repelled by electrostatic force.
- 31 Metal sphere *A* has a charge of  $-2$  units and an identical metal sphere, *B*, has a charge of  $-4$  units. If the spheres are brought into contact with each other and then separated, the charge on sphere *B* will be
- (1) 0 units
  - (2)  $-2$  units
  - (3)  $-3$  units
  - (4)  $+4$  units
- 32 A photon of light traveling through space with a wavelength of  $6.0 \times 10^{-7}$  meter has an energy of
- (1)  $4.0 \times 10^{-40}$  J
  - (2)  $3.3 \times 10^{-19}$  J
  - (3)  $5.4 \times 10^{10}$  J
  - (4)  $5.0 \times 10^{14}$  J
- 33 What is the net electrical charge on a magnesium ion that is formed when a neutral magnesium atom loses two electrons?
- (1)  $-3.2 \times 10^{-19}$  C
  - (2)  $-1.6 \times 10^{-19}$  C
  - (3)  $+1.6 \times 10^{-19}$  C
  - (4)  $+3.2 \times 10^{-19}$  C
- 34 The charge of an antistrange quark is approximately
- (1)  $+5.33 \times 10^{-20}$  C
  - (2)  $-5.33 \times 10^{-20}$  C
  - (3)  $+5.33 \times 10^{20}$  C
  - (4)  $-5.33 \times 10^{20}$  C
- 35 What fundamental force holds quarks together to form particles such as protons and neutrons?
- (1) electromagnetic force
  - (2) gravitational force
  - (3) strong force
  - (4) weak force

Part B-1

Answer all questions in this part.

Directions (36–51): For each statement or question, write on the separate answer sheet the number of the word or expression that, of those given, best completes the statement or answers the question.

36 A cart travels with a constant nonzero acceleration along a straight line. Which graph best represents the relationship between the distance the cart travels and time of travel?

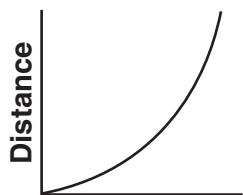

Time

(1)

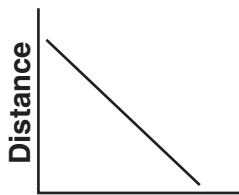

Time

(2)

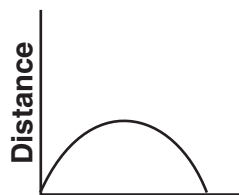

Time

(3)

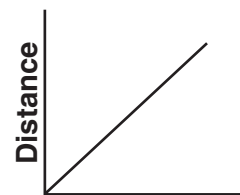

Time

(4)

37 Which graph best represents the relationship between the acceleration of an object falling freely near the surface of Earth and the time that it falls?

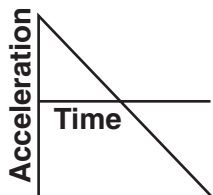

Time

(1)

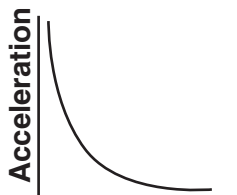

Time

(2)

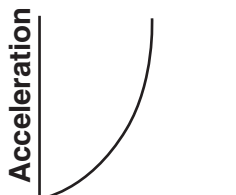

Time

(3)

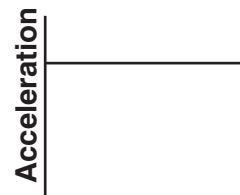

Acceleration

Time

(4)

38 The diagram below shows a 4.0-kilogram object accelerating at 10. meters per second<sup>2</sup> on a rough horizontal surface.

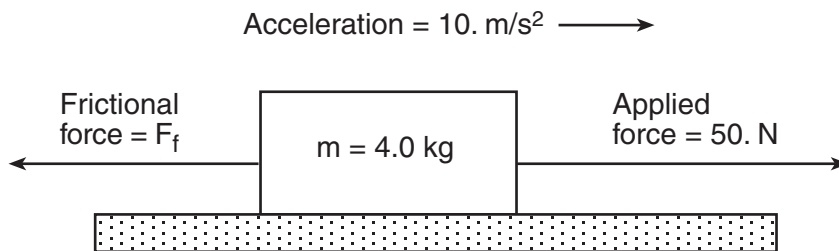

(Not drawn to scale)

What is the magnitude of the frictional force  $F_f$  acting on the object?

- (1) 5.0 N
- (2) 10. N

- (3) 20. N
- (4) 40. N

39 What is the magnitude of the force needed to keep a 60.-newton rubber block moving across level, dry asphalt in a straight line at a constant speed of 2.0 meters per second?

- (1) 40. N
- (2) 51 N
- (3) 60. N
- (4) 120 N

40 Which graph best represents the relationship between the gravitational potential energy of an object near the surface of Earth and its height above Earth’s surface?

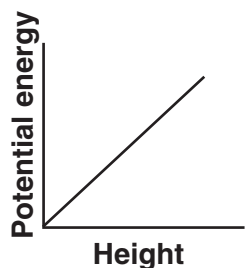

( 1 )

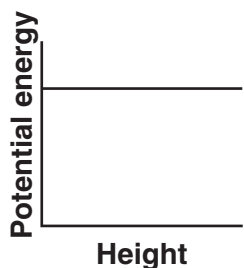

( 2 )

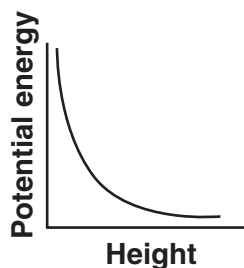

( 3 )

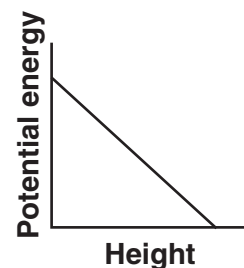

( 4 )

Base your answers to questions 41 through 43 on the diagram below, which represents an electric circuit consisting of four resistors and a 12-volt battery.

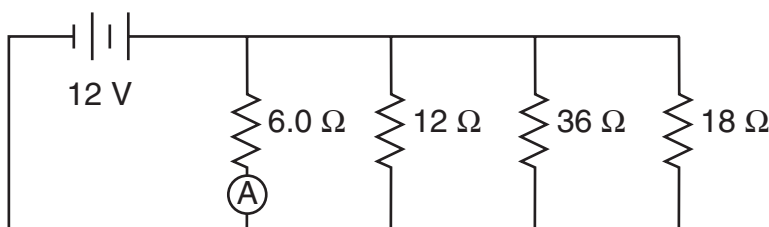

41 What is the current measured by ammeter A?

- (1) 0.50 A
- (2) 2.0 A
- (3) 72 A
- (4) 4.0 A

42 What is the equivalent resistance of this circuit?

- (1) 72 Ω
- (2) 18 Ω
- (3) 3.0 Ω
- (4) 0.33 Ω

43 How much power is dissipated in the 36-ohm resistor?

- (1) 110 W
- (2) 48 W
- (3) 3.0 W
- (4) 4.0 W

44 A 1.00-kilogram ball is dropped from the top of a building. Just before striking the ground, the ball's speed is 12.0 meters per second. What was the ball's gravitational potential energy, relative to the ground, at the instant it was dropped? [Neglect friction.]

- (1) 6.00 J                      (3) 72.0 J  
(2) 24.0 J                      (4) 144 J

45 As shown in the diagram below, a child applies a constant 20.-newton force along the handle of a wagon which makes a  $25^\circ$  angle with the horizontal.

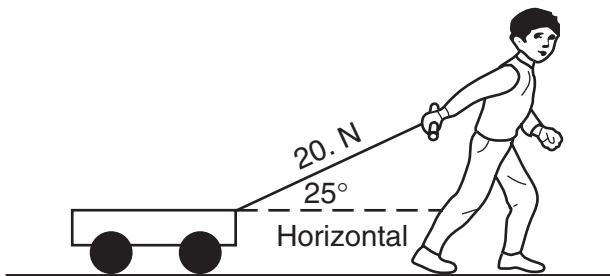

How much work does the child do in moving the wagon a horizontal distance of 4.0 meters?

- (1) 5.0 J                      (3) 73 J  
(2) 34 J                      (4) 80. J

46 A 110-kilogram bodybuilder and his 55-kilogram friend run up identical flights of stairs. The bodybuilder reaches the top in 4.0 seconds while his friend takes 2.0 seconds. Compared to the power developed by the bodybuilder while running up the stairs, the power developed by his friend is

- (1) the same  
(2) twice as much  
(3) half as much  
(4) four times as much

47 Which quantity and unit are correctly paired?

- (1) resistivity and  $\frac{\Omega}{\text{m}}$   
(2) potential difference and eV  
(3) current and C•s  
(4) electric field strength and  $\frac{\text{N}}{\text{C}}$

48 Which wavelength is in the infrared range of the electromagnetic spectrum?

- (1) 100 nm                      (3) 100 m  
(2) 100 mm                      (4) 100  $\mu\text{m}$



49 The diagram below represents a wave.

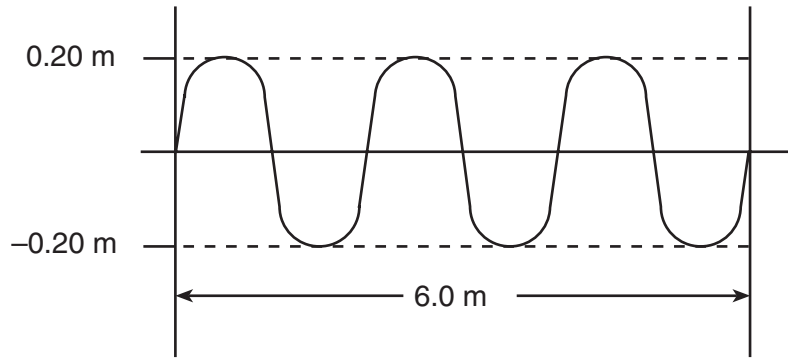

What is the speed of the wave if its frequency is 8.0 hertz?

- (1) 48 m/s
- (2) 16 m/s
- (3) 3.2 m/s
- (4) 1.6 m/s

50 What is the wavelength of a light ray with frequency  $5.09 \times 10^{14}$  hertz as it travels through Lucite?

- (1)  $3.93 \times 10^{-7}$  m
- (2)  $5.89 \times 10^{-7}$  m
- (3)  $3.39 \times 10^{14}$  m
- (4)  $7.64 \times 10^{14}$  m

51 What is the total number of quarks in a helium nucleus consisting of 2 protons and 2 neutrons?

- (1) 16
  - (2) 12
  - (3) 8
  - (4) 4
-

**Part B–2**

**Answer all questions in this part.**

*Directions (52–62):* Record your answers in the spaces provided in your answer booklet.

Base your answers to questions 52 through 54 on the information and diagram below.

Force *A* with a magnitude of 5.6 newtons and force *B* with a magnitude of 9.4 newtons act concurrently on point *P*.

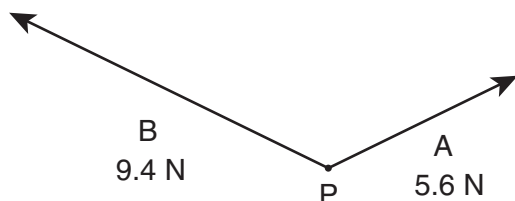

- 52 Determine the scale used in the diagram. [1]
- 53 On the diagram *in your answer booklet*, use a ruler and protractor to construct a vector representing the resultant of forces *A* and *B*. [1]
- 54 Determine the magnitude of the resultant force. [1]
- \_\_\_\_\_
- 55 Calculate the resistance of a 1.00-kilometer length of nichrome wire with a cross-sectional area of  $3.50 \times 10^{-6}$  meter<sup>2</sup> at 20°C. [Show all work, including the equation and substitution with units.] [2]
- 56 A generator produces a 115-volt potential difference and a maximum of 20.0 amperes of current. Calculate the total electrical energy the generator produces operating at maximum capacity for 60. seconds. [Show all work, including the equation and substitution with units.] [2]

Base your answers to questions 57 through 59 on the information and data table below.

A student performed an experiment in which the weight attached to a suspended spring was varied and the resulting total length of the spring measured. The data for the experiment are in the table below.

**Attached Weight vs. Total Spring Length**

| Attached Weight (N) | Total Spring Length (m) |
|---------------------|-------------------------|
| 0.98                | 0.37                    |
| 1.96                | 0.42                    |
| 2.94                | 0.51                    |
| 3.92                | 0.59                    |
| 4.91                | 0.64                    |

*Directions (57–58):* Using the information in the data table, construct a graph on the grid in your answer booklet, following the directions below.

- 57 Plot the data points for the attached weight versus total spring length. [1]
- 58 Draw the line or curve of best fit. [1]
- 59 Using your graph, determine the length of the spring before any weight was attached. [1]
- \_\_\_\_\_

60 The graph below represents the relationship between wavelength and frequency of waves created by two students shaking the ends of a loose spring.

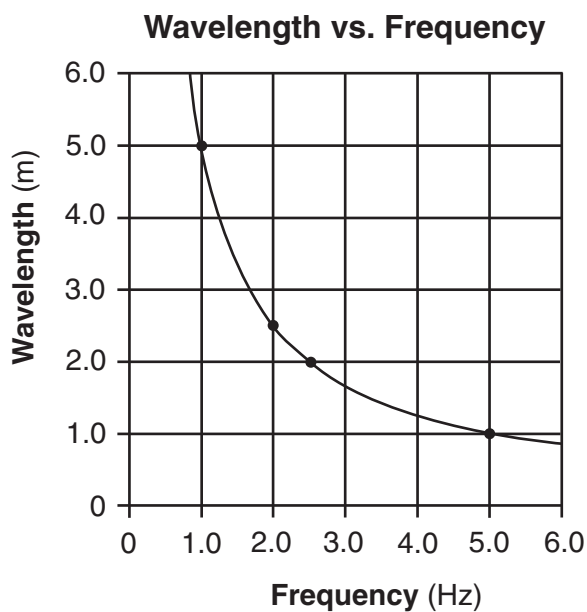

Calculate the speed of the waves generated in the spring. [Show all work, including the equation and substitution with units.] [2]

Base your answers to questions 61 and 62 on the statement below.

The spectrum of visible light emitted during transitions in excited hydrogen atoms is composed of blue, green, red, and violet lines.

61 What characteristic of light determines the amount of energy carried by a photon of that light?

- |               |              |
|---------------|--------------|
| (1) amplitude | (3) phase    |
| (2) frequency | (4) velocity |

62 Which color of light in the visible hydrogen spectrum has photons of the shortest wavelength?

- |           |            |
|-----------|------------|
| (1) blue  | (3) red    |
| (2) green | (4) violet |

**Part C**

**Answer all questions in this part.**

*Directions (63–77):* Record your answers in the spaces provided in your answer booklet.

Base your answers to questions 63 through 66 on the information and diagram below.

A spark timer is used to record the position of a lab cart accelerating uniformly from rest. Each 0.10 second, the timer marks a dot on a recording tape to indicate the position of the cart at that instant, as shown.

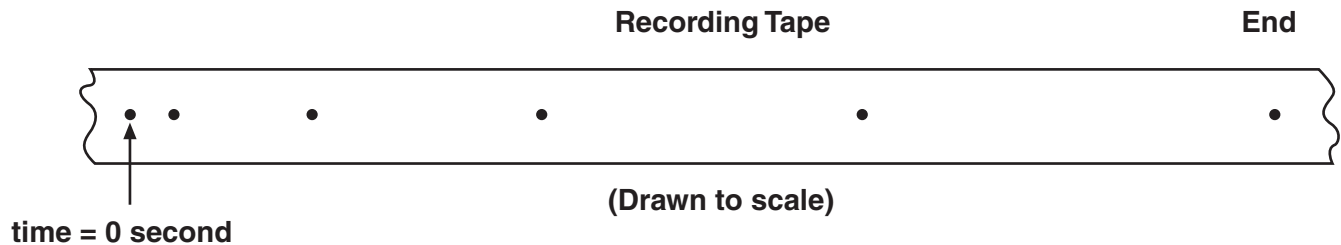

- 63 Using a metric ruler, measure the distance the cart traveled during the interval  $t = 0$  second to  $t = 0.30$  second. Record your answer *in your answer booklet*, to the nearest tenth of a centimeter. [1]
- 64 Calculate the magnitude of the acceleration of the cart during the time interval  $t = 0$  second to  $t = 0.30$  second. [Show all work, including the equation and substitution with units.] [2]
- 65 Calculate the average speed of the cart during the time interval  $t = 0$  second to  $t = 0.30$  second. [Show all work, including the equation and substitution with units.] [2]
- 66 On the diagram *in your answer booklet*, mark *at least four* dots to indicate the position of a cart traveling at a constant velocity. [1]
-

Base your answers to questions 67 through 69 on the information and diagram below.

A 50.-ohm resistor, an unknown resistor  $R$ , a 120-volt source, and an ammeter are connected in a complete circuit. The ammeter reads 0.50 ampere.

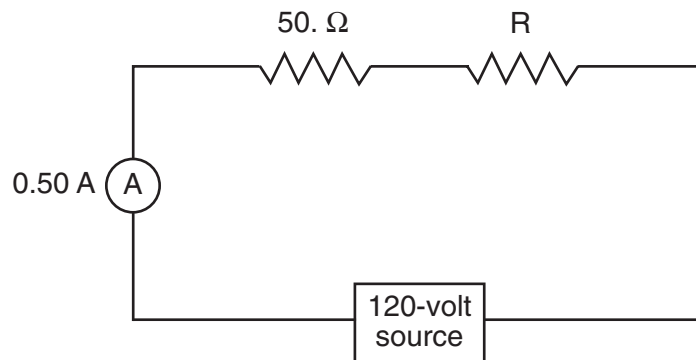

- 67 Calculate the equivalent resistance of the circuit. [Show all work, including the equation and substitution with units.] [2]
- 68 Determine the resistance of resistor  $R$ . [1]
- 69 Calculate the power dissipated by the 50.-ohm resistor. [Show all work, including the equation and substitution with units.] [2]
-

Base your answers to questions 70 through 73 on the information and diagram below.

A ray of light ( $f = 5.09 \times 10^{14}$  Hz) is incident on the boundary between air and an unknown material X at an angle of incidence of  $55^\circ$ , as shown. The absolute index of refraction of material X is 1.66.

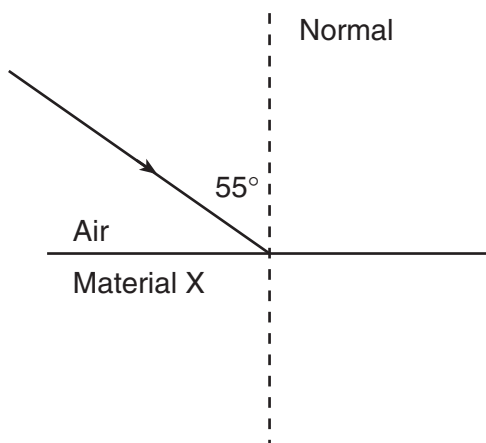

- 70 Identify a substance of which material X may be composed. [1]
- 71 Determine the speed of this ray of light in material X. [1]
- 72 Calculate the angle of refraction of the ray of light in material X. [Show all work, including the equation and substitution with units.] [2]
- 73 On the diagram *in your answer booklet*, use a straightedge and protractor to draw the refracted ray of light in material X. [1]
-

Base your answers to questions 74 through 77 on the passage below and on your knowledge of physics.

### More Sci- Than Fi, Physicists Create Antimatter

Physicists working in Europe announced yesterday that they had passed through nature's looking glass and had created atoms made of antimatter, or antiatoms, opening up the possibility of experiments in a realm once reserved for science fiction writers. Such experiments, theorists say, could test some of the basic tenets of modern physics and light the way to a deeper understanding of nature.

By corraling [holding together in groups] clouds of antimatter particles in a cylindrical chamber laced with detectors and electric and magnetic fields, the physicists assembled antihydrogen atoms, the looking glass equivalent of hydrogen, the most simple atom in nature. Whereas hydrogen consists of a positively charged proton circled by a negatively charged electron, in antihydrogen the proton's counterpart, a positively charged antiproton, is circled by an antielectron, otherwise known as a positron.

According to the standard theories of physics, the antimatter universe should look identical to our own. Antihydrogen and hydrogen atoms should have the same properties, emitting the exact same frequencies of light, for example. . . .

Antimatter has been part of physics since 1927 when its existence was predicted by the British physicist Paul Dirac. The antielectron, or positron, was discovered in 1932. According to the theory, matter can only be created in particle-antiparticle pairs. It is still a mystery, cosmologists say, why the universe seems to be overwhelmingly composed of normal matter.

Dennis Overbye, "More Sci- Than Fi, Physicists Create Antimatter," *New York Times*, Sept. 19, 2002

- 74 The author of the passage concerning antimatter incorrectly reported the findings of the experiment on antimatter. Which particle mentioned in the article has the charge incorrectly identified? [1]
- 75 How should the emission spectrum of antihydrogen compare to the emission spectrum of hydrogen? [1]
- 76 Identify *one* characteristic that antimatter particles must possess if clouds of them can be corralled by electric and magnetic fields. [1]
- 77 According to the article, why is it a mystery that "the universe seems to be overwhelmingly composed of normal matter"? [1]
-









The University of the State of New York

REGENTS HIGH SCHOOL EXAMINATION

PHYSICAL SETTING  
PHYSICS

Thursday, January 25, 2007 — 1:15 to 4:15 p.m., only

ANSWER SHEET

Student ..... Sex:  Male  Female Grade .....

Teacher ..... School .....

Record your answers to Part A and Part B-1 on this answer sheet.

Part A

- 1 ..... 13 ..... 25 .....
- 2 ..... 14 ..... 26 .....
- 3 ..... 15 ..... 27 .....
- 4 ..... 16 ..... 28 .....
- 5 ..... 17 ..... 29 .....
- 6 ..... 18 ..... 30 .....
- 7 ..... 19 ..... 31 .....
- 8 ..... 20 ..... 32 .....
- 9 ..... 21 ..... 33 .....
- 10 ..... 22 ..... 34 .....
- 11 ..... 23 ..... 35 .....
- 12 ..... 24 .....

Part A Score

Part B-1

- 36 ..... 44 .....
- 37 ..... 45 .....
- 38 ..... 46 .....
- 39 ..... 47 .....
- 40 ..... 48 .....
- 41 ..... 49 .....
- 42 ..... 50 .....
- 43 ..... 51 .....

Part B-1 Score

Write your answers to Part B-2 and Part C in your answer booklet.

The declaration below should be signed when you have completed the examination.

I do hereby affirm, at the close of this examination, that I had no unlawful knowledge of the questions or answers prior to the examination and that I have neither given nor received assistance in answering any of the questions during the examination.

Signature

Tear Here

Tear Here

PS/PHYSICS

Tear Here

Tear Here

PS/PHYSICS

# PHYSICAL SETTING PHYSICS

Thursday, January 25, 2007 — 1:15 to 4:15 p.m., only

## ANSWER BOOKLET

Student ..... Sex:  Male  
 Female  
Teacher.....  
School..... Grade .....

Answer all questions in Part B-2 and Part C. Record your answers in this booklet.

| Part  | Maximum Score | Student's Score      |
|---|---------------|----------------------|
| A   | 35            |                      |
| B-1   | 16            |                      |
| B-2   | 14            |                      |
| C   | 20            |                      |
| Total Written Test Score<br>(Maximum Raw Score: 85) |               | <input type="text"/> |
| Final Score<br>(From Conversion Chart)              |               | <input type="text"/> |
| Raters' Initials:<br>Rater 1 ..... Rater 2.....     |               |                      |

### Part B-2

52 1.0 cm = \_\_\_\_\_ N

55

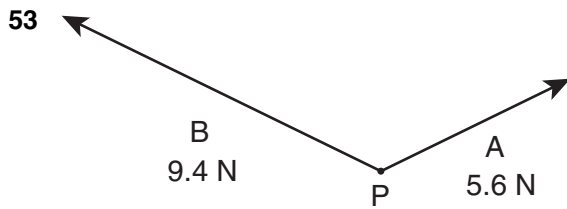

56

54 \_\_\_\_\_ N

57-58

**Attached Weight vs. Total Spring Length**

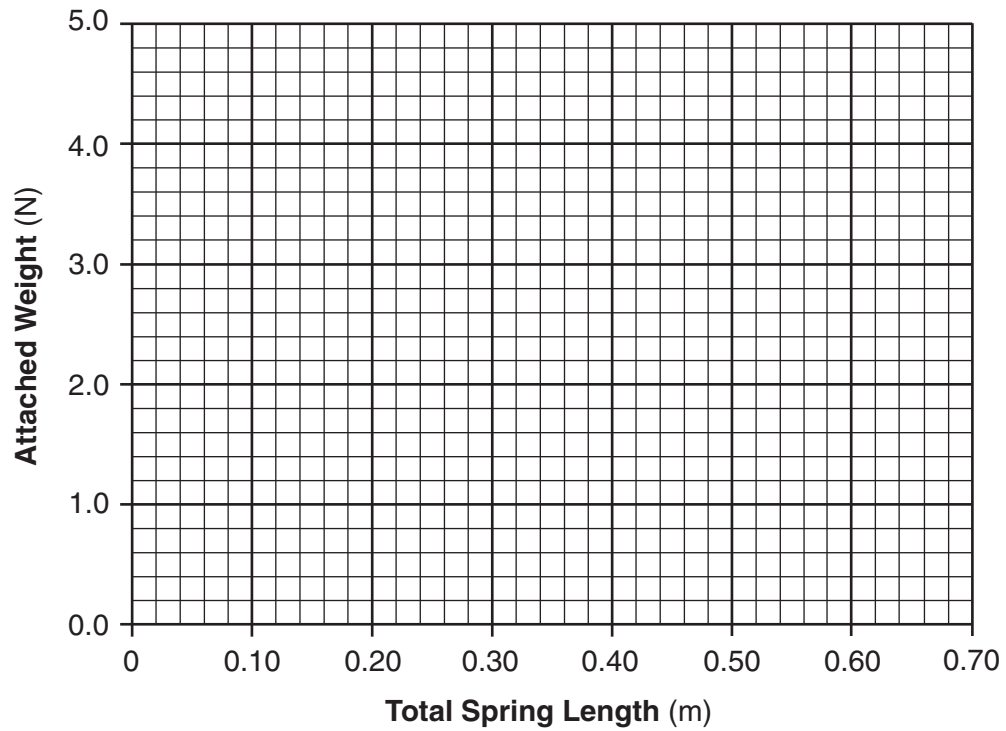

59 \_\_\_\_\_ m

60

61 \_\_\_\_\_

62 \_\_\_\_\_

**Part C**

63 \_\_\_\_\_ cm

64

65

66

**Recording Tape**



67

68 \_\_\_\_\_  $\Omega$

69

70 \_\_\_\_\_

71 \_\_\_\_\_ m/s

72

73

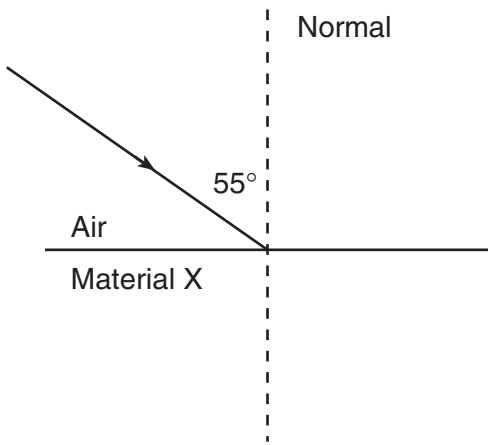

74 \_\_\_\_\_

75 \_\_\_\_\_

76 \_\_\_\_\_

77 \_\_\_\_\_

\_\_\_\_\_