

The University of the State of New York  
REGENTS HIGH SCHOOL EXAMINATION

# ALGEBRA 2/TRIGONOMETRY

Wednesday, August 17, 2016 — 12:30 to 3:30 p.m., only

Student Name: \_\_\_\_\_

School Name: \_\_\_\_\_

The possession or use of any communications device is strictly prohibited when taking this examination. If you have or use any communications device, no matter how briefly, your examination will be invalidated and no score will be calculated for you.

Print your name and the name of your school on the lines above.

A separate answer sheet for Part I has been provided to you. Follow the instructions from the proctor for completing the student information on your answer sheet.

This examination has four parts, with a total of 39 questions. You must answer all questions in this examination. Record your answers to the Part I multiple-choice questions on the separate answer sheet. Write your answers to the questions in Parts II, III, and IV directly in this booklet. All work should be written in pen, except for graphs and drawings, which should be done in pencil. Clearly indicate the necessary steps, including appropriate formula substitutions, diagrams, graphs, charts, etc.

The formulas that you may need to answer some questions in this examination are found at the end of the examination. This sheet is perforated so you may remove it from this booklet.

Scrap paper is not permitted for any part of this examination, but you may use the blank spaces in this booklet as scrap paper. A perforated sheet of scrap graph paper is provided at the end of this booklet for any question for which graphing may be helpful but is not required. You may remove this sheet from this booklet. Any work done on this sheet of scrap graph paper will *not* be scored.

When you have completed the examination, you must sign the statement printed at the end of the answer sheet, indicating that you had no unlawful knowledge of the questions or answers prior to the examination and that you have neither given nor received assistance in answering any of the questions during the examination. Your answer sheet cannot be accepted if you fail to sign this declaration.

Notice...

A graphing calculator and a straightedge (ruler) must be available for you to use while taking this examination.

DO NOT OPEN THIS EXAMINATION BOOKLET UNTIL THE SIGNAL IS GIVEN.

## Part I

Answer all 27 questions in this part. Each correct answer will receive 2 credits. For each statement or question, choose the word or expression that, of those given, best completes the statement or answers the question. Record your answers on your separate answer sheet. [54]

Use this space for computations.

1 If the roots of the quadratic equation  $ax^2 + bx + c = 0$  are real, irrational, and unequal, then the value of the discriminant is

- (1) equal to zero
- (2) less than zero
- (3) greater than zero and a perfect square
- (4) greater than zero and not a perfect square

2 Factored completely, the expression  $16 \tan \theta - \tan^3 \theta$  is equivalent to

- (1)  $\tan \theta (4 - \tan \theta)^2$
- (2)  $\tan \theta (\tan \theta - 4)^2$
- (3)  $\tan \theta (4 - \tan \theta)(4 + \tan \theta)$
- (4)  $\tan \theta (\tan \theta + 4)(\tan \theta - 4)$

3 High school officials wanted to assess the need for a new diving board. They created a survey and distributed it to a large, diverse crowd at the State Swim Meet held at their school. Which characteristic of the survey is most likely to create a bias?

- (1) the number of participants
- (2) the height of the participants
- (3) the way the set of data from the survey was analyzed
- (4) the way the participants were selected to take the survey

4 Which expression is equivalent to  $\cos P \cos 50 - \sin P \sin 50$ ?

- (1)  $\cos (P - 50)$
- (2)  $\sin (P - 50)$
- (3)  $\cos (P + 50)$
- (4)  $\sin (P + 50)$

Use this space for computations.

5 What is the product of the roots of the quadratic equation  $2x^2 - x = 4$ ?

- (1)  $\frac{1}{2}$  (3)  $-2$   
(2)  $2$  (4)  $4$

6 In which method of data collection does the researcher intentionally intervene to arrange for a comparison of results?

- (1) taking a survey  
(2) making observations  
(3) filling out a questionnaire  
(4) conducting a controlled experiment

7 Which equation could be represented by the graph below?

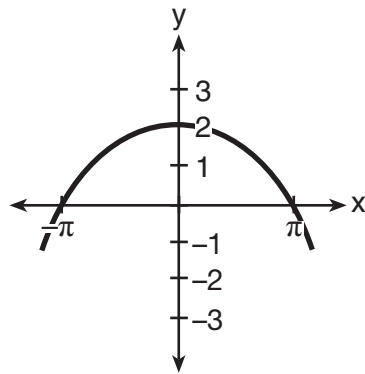

- (1)  $y = 2 \sin \frac{1}{2}x$  (3)  $y = \frac{1}{2} \sin 2x$   
(2)  $y = 2 \cos \frac{1}{2}x$  (4)  $y = \frac{1}{2} \cos 2x$

8 The first four terms of the sequence with  $a_1 = 40$  and  $a_n = \frac{3}{4}a_{n-1}$  are

- (1)  $30, 22, 17, 13$  (3)  $40, 30, 22, 17$   
(2)  $40, 30, 22\frac{1}{2}, 16\frac{7}{8}$  (4)  $30, 22\frac{1}{2}, 16\frac{7}{8}, 12\frac{21}{33}$

Use this space for computations.

9 Which diagram represents an angle of  $\frac{7}{4}\pi$  radians in standard position?

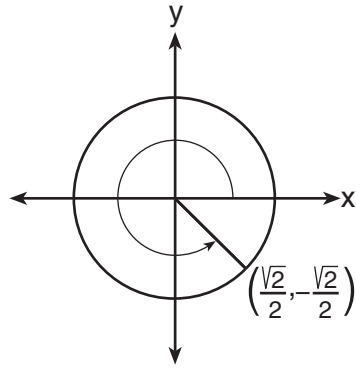

(1)

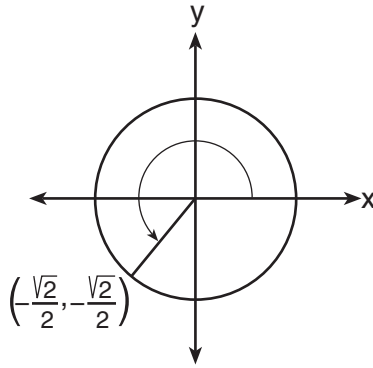

(3)

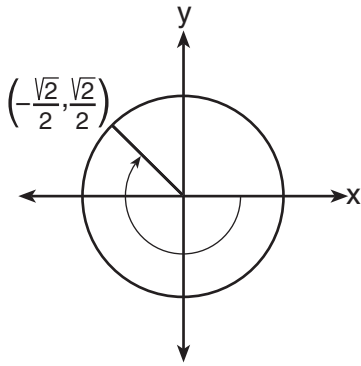

(2)

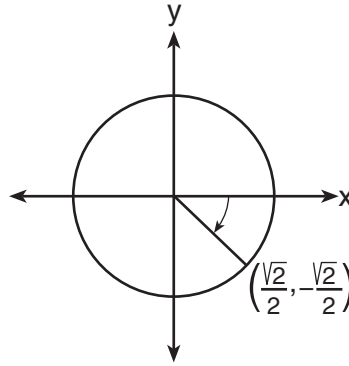

(4)

10 For all values for which the function is defined, the expression  $\sqrt{\frac{a}{bc}}$  is equivalent to

(1)  $\sqrt{a}$

(3)  $\sqrt{abc}$

(2)  $\frac{a\sqrt{bc}}{bc}$

(4)  $\frac{\sqrt{abc}}{bc}$

11 The expression  $\left(x^{\frac{1}{2}}y^{-\frac{2}{3}}\right)^{-6}$  is equivalent to

(1)  $\frac{y^4}{x^3}$

(3)  $\frac{1}{x^3y^4}$

(2)  $\frac{x^3}{y^4}$

(4)  $x^3y^4$

Use this space for computations.

12 The value of  $\sum_{x=4}^8 i^x$ , where  $i$  is the imaginary unit, is

- (1) 1 (3)  $i$   
(2)  $-1$  (4)  $-i$

13 Which expression has a value of  $\frac{\sqrt{3}}{3}$ ?

- (1)  $\cot 60^\circ$  (3)  $\csc 30^\circ$   
(2)  $\tan 60^\circ$  (4)  $\sec 30^\circ$

14 The solution set of  $-|2x - 9| = -11$  is

- (1)  $\{\}$  (3)  $\{1, 10\}$   
(2)  $\{10\}$  (4)  $\{-1, 10\}$

15 Which relation is *not* a function?

- (1)  $y = 2|x| + 3$  (3)  $3x^2 + 3y = 20$   
(2)  $y = -5(3.2)^x$  (4)  $4x^2 + 3y^2 = 9$

16 The expression  $\frac{1 - \sin^2 x}{\cos^2 x}$  is equivalent to

- (1) 1 (3)  $\cos x$   
(2)  $-1$  (4)  $\sin x$

17 Which relation is one-to-one?

- (1)  $x = 3$  (3)  $y = \log x$   
(2)  $y = x^2 - 2x$  (4)  $y = |x|$

Use this space for  
computations.

18 If  $\log a = x$  and  $\log b = y$ , then  $\log (ab^2)$  equals

(1)  $\frac{1}{2}(x + y)$

(3)  $x + 2y$

(2)  $x + \frac{1}{2}y$

(4)  $2x + 2y$

19 For a member of a certain species of bird, the probability of surviving to adulthood is  $\frac{4}{7}$ . In a nest of five eggs, what is the probability, to the nearest hundredth, that at least four eggs will survive to adulthood?

(1) 0.23

(3) 0.63

(2) 0.29

(4) 0.94

20 In  $\triangle XYZ$ ,  $m\angle X = 71$ ,  $x = 6$ , and  $z = 2$ . How many distinct triangles can be created with these parameters?

(1) 1

(3) 3

(2) 2

(4) 0

21 Which expression could be used to determine the value of  $y$  in the equation  $\log_x 8 = y$ ?

(1)  $\frac{\log 8}{x}$

(3)  $\frac{8}{\log x}$

(2)  $\frac{\log 8}{\log x}$

(4)  $\frac{\log x}{\log 8}$

22 An electron travels along a circular path with a radius of 4.6 miles. What is the number of miles the electron traveled during an interval when the central angle formed by the electron's path was  $220^\circ$ ?

(1) 3.84

(3) 17.66

(2) 8.83

(4) 1012

**Use this space for  
computations.**

**23** Which statement about the function  $f(x) = \frac{x-3}{x+2}$  is true?

- (1) Its domain does not include 2.
- (2) Its domain does not include 3.
- (3) Its range does not include 1.
- (4) Its range does not include  $-\frac{3}{2}$ .

**24** Which value of a correlation coefficient represents the strongest relationship between the two variables in a given linear regression model?

- (1)  $-0.94$
- (2) 0
- (3) 0.5
- (4) 0.91

**25** The fourth term of the expansion of  $(2x - 3)^5$  is

- (1)  $-1080x^2$
- (2)  $-540x^2$
- (3)  $720x^3$
- (4)  $810x$

**26** What are the center and radius of the circle whose equation is  $x^2 + y^2 + 4x = 5$ ?

- (1) (2,0) and 1
- (2) (-2,0) and 1
- (3) (2,0) and 3
- (4) (-2,0) and 3

**27** The product of  $\sqrt[3]{4m^2}$  and  $\sqrt[3]{10m}$  expressed in simplest radical form is

- (1)  $\sqrt[3]{40m^3}$
- (2)  $2\sqrt[3]{5m^3}$
- (3)  $m\sqrt[3]{40}$
- (4)  $2m\sqrt[3]{5}$

## Part II

**Answer all 8 questions in this part. Each correct answer will receive 2 credits. Clearly indicate the necessary steps, including appropriate formula substitutions, diagrams, graphs, charts, etc. For all questions in this part, a correct numerical answer with no work shown will receive only 1 credit. All answers should be written in pen, except for graphs and drawings, which should be done in pencil. [16]**

**28** Jamal has forgotten his password for the school computers. He knows that it must be 4 characters long (only lowercase letters or digits). He also knows that his password begins with one of 26 letters and ends with a digit. Determine how many different 4-character passwords are possible for Jamal if no letter or digit may be repeated.



**29** Emma's parents deposited \$5000 into a bank account during her freshman year. The account pays 5% interest compounded continuously using the formula  $A = Pe^{rt}$ , where  $A$  is the total amount accrued,  $P$  is the principal,  $r$  is the annual interest rate, and  $t$  is time, in years.

Determine, to the *nearest dollar*, the amount in the account 4 years later.

**30** Find the common difference in the arithmetic sequence,  $a_n$ , in which  $a_1 = 16$  and  $a_9 = 36$ .

**31** Solve the equation below algebraically for all values of  $\theta$  in the interval  $0 \leq \theta < 360^\circ$ .

$$3 \cos \theta - 1 = \cos \theta$$

**32** Bacteria are being grown in a Petri dish in a biology lab. The number of bacteria in the culture after a given number of hours is shown in the table below.

Hour	1	2	3	4	5
Bacteria	1990	2200	2430	2685	2965

Assuming this exponential trend continues, is it reasonable to expect *at least* 3500 bacteria at hour 7?

Justify your answer.

**33** Express in simplest form:

$$\left(\frac{a}{b} - \frac{b}{a}\right) \div \left(\frac{b}{a} - \frac{a}{b}\right)$$

**34** Determine the exact value of  $\csc P$  if  $P$  is an angle in standard position and its terminal side passes through the point  $(5, -8)$ .

**35** Determine the number of degrees in  $\frac{8\pi}{9}$  radians.

### Part III

Answer all 3 questions in this part. Each correct answer will receive 4 credits. Clearly indicate the necessary steps, including appropriate formula substitutions, diagrams, graphs, charts, etc. For all questions in this part, a correct numerical answer with no work shown will receive only 1 credit. All answers should be written in pen, except for graphs and drawings, which should be done in pencil. [12]

36 Solve for  $x$ :

$$8^{x+3} = 32^{x^2-1}$$

**37** Determine algebraically the solution to  $4x^2 - 5x \geq 6(5 - 4x)$ .



38 The table below shows the number of hurricanes in the North Atlantic Ocean from 1990 to 2002.

**North Atlantic Ocean Hurricanes**

<b>Number of Hurricanes</b>	8	4	4	4	3	11	9	3	10	8	8	9	4
-----------------------------	---	---	---	---	---	----	---	---	----	---	---	---	---

Determine the interquartile range for this set of data.

Determine the population variance for this set of data, to the *nearest tenth*.

#### Part IV

**Answer the question in this part. A correct answer will receive 6 credits. Clearly indicate the necessary steps, including appropriate formula substitutions, diagrams, graphs, charts, etc. A correct numerical answer with no work shown will receive only 1 credit. The answer should be written in pen. [6]**

**39** The Bermuda Triangle on a map is a section of the Atlantic Ocean bordered by line segments stretching from Miami to Bermuda to Puerto Rico and back to Miami. The distance from Miami to Bermuda is 1042 miles; the distance from Bermuda to Puerto Rico is 2057 miles; and the distance from Puerto Rico to Miami is 1127 miles. Find the area contained within the Bermuda Triangle, to the *nearest square mile*.

Tear Here

## Reference Sheet

### Area of a Triangle

$$K = \frac{1}{2} ab \sin C$$

### Functions of the Sum of Two Angles

$$\sin(A + B) = \sin A \cos B + \cos A \sin B$$

$$\cos(A + B) = \cos A \cos B - \sin A \sin B$$

$$\tan(A + B) = \frac{\tan A + \tan B}{1 - \tan A \tan B}$$

### Functions of the Difference of Two Angles

$$\sin(A - B) = \sin A \cos B - \cos A \sin B$$

$$\cos(A - B) = \cos A \cos B + \sin A \sin B$$

$$\tan(A - B) = \frac{\tan A - \tan B}{1 + \tan A \tan B}$$

### Law of Sines

$$\frac{a}{\sin A} = \frac{b}{\sin B} = \frac{c}{\sin C}$$

### Sum of a Finite Arithmetic Series

$$S_n = \frac{n(a_1 + a_n)}{2}$$

### Binomial Theorem

$$(a + b)^n = {}_n C_0 a^n b^0 + {}_n C_1 a^{n-1} b^1 + {}_n C_2 a^{n-2} b^2 + \dots + {}_n C_n a^0 b^n$$

$$(a + b)^n = \sum_{r=0}^n {}_n C_r a^{n-r} b^r$$

### Law of Cosines

$$a^2 = b^2 + c^2 - 2bc \cos A$$

### Functions of the Double Angle

$$\sin 2A = 2 \sin A \cos A$$

$$\cos 2A = \cos^2 A - \sin^2 A$$

$$\cos 2A = 2 \cos^2 A - 1$$

$$\cos 2A = 1 - 2 \sin^2 A$$

$$\tan 2A = \frac{2 \tan A}{1 - \tan^2 A}$$

### Functions of the Half Angle

$$\sin \frac{1}{2} A = \pm \sqrt{\frac{1 - \cos A}{2}}$$

$$\cos \frac{1}{2} A = \pm \sqrt{\frac{1 + \cos A}{2}}$$

$$\tan \frac{1}{2} A = \pm \sqrt{\frac{1 - \cos A}{1 + \cos A}}$$

### Sum of a Finite Geometric Series

$$S_n = \frac{a_1(1 - r^n)}{1 - r}$$

### Normal Curve Standard Deviation

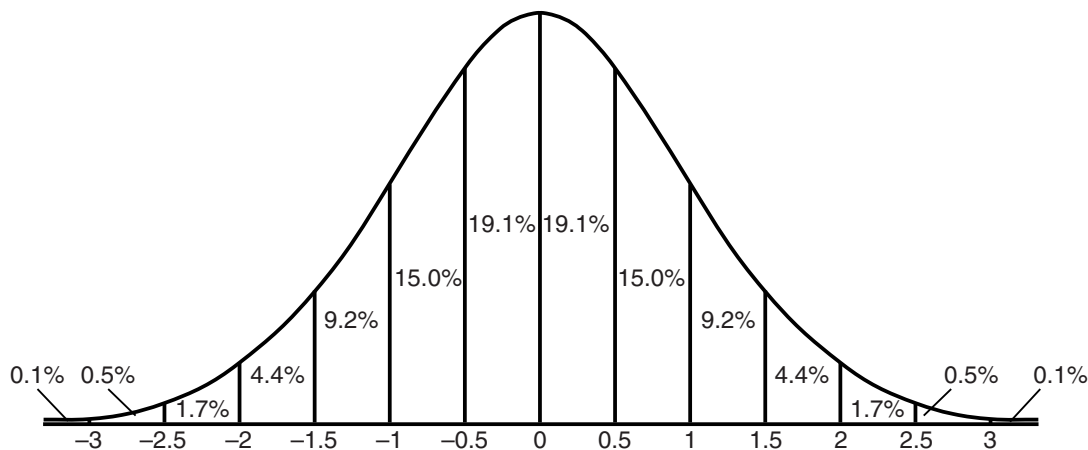

Tear Here

Tear Here

Tear Here

**Scrap Graph Paper — This sheet will *not* be scored.**

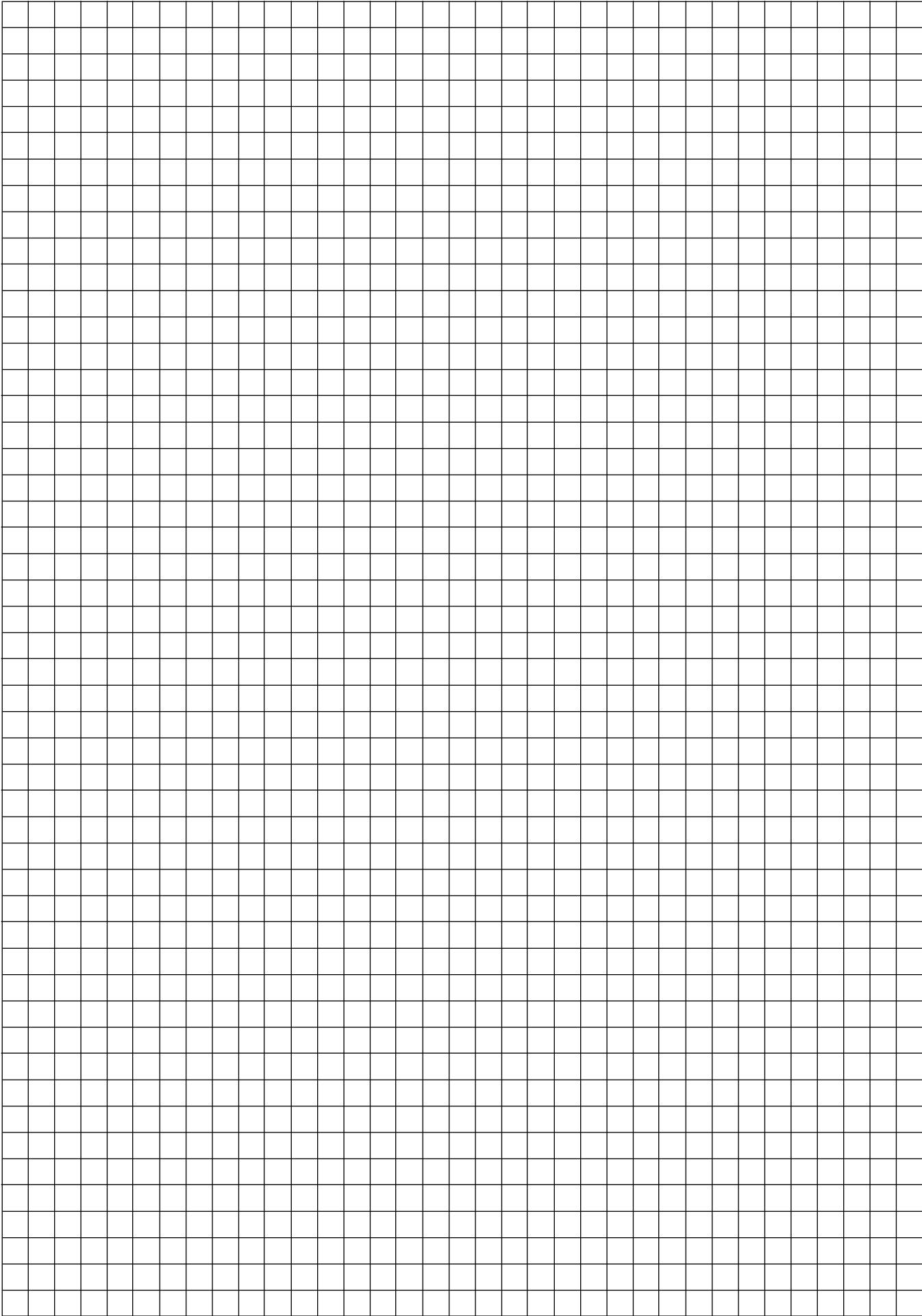

Tear Here

Tear Here

**Scrap Graph Paper — This sheet will *not* be scored.**

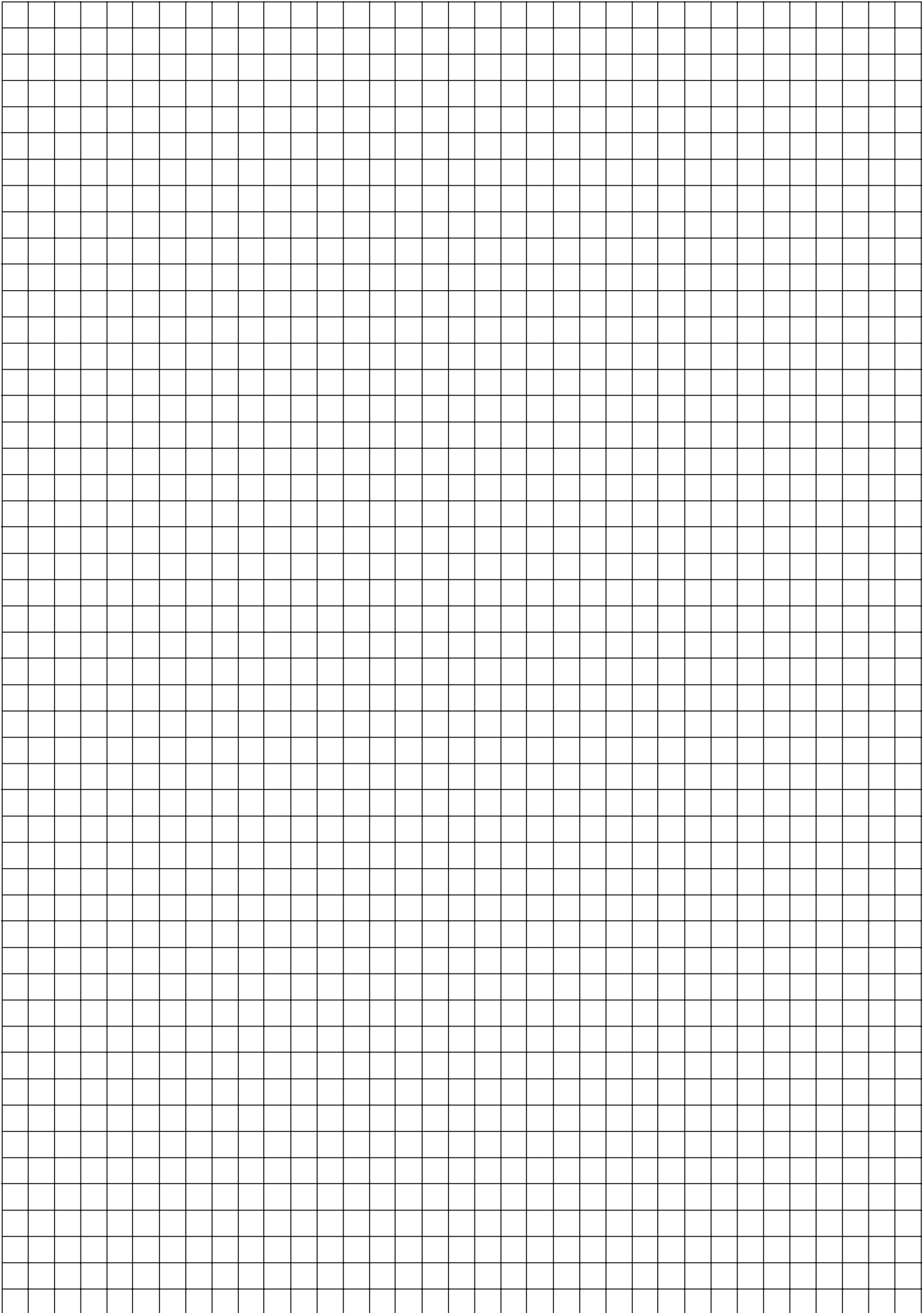

Tear Here

Tear Here



