

Large-Type Edition

The University of the State of New York

REGENTS HIGH SCHOOL EXAMINATION

PHYSICAL SETTING CHEMISTRY

Friday, January 24, 2020 — 9:15 a.m. to 12:15 p.m., only

The possession or use of any communications device is strictly prohibited when taking this examination. If you have or use any communications device, no matter how briefly, your examination will be invalidated and no score will be calculated for you.

This is a test of your knowledge of chemistry. Use that knowledge to answer all questions in this examination. Some questions may require the use of the *2011 Edition Reference Tables for Physical Setting/Chemistry*. You are to answer *all* questions in all parts of this examination according to the directions provided in this examination booklet.

A separate answer sheet for Part A and Part B–1 has been provided to you. Follow the instructions from the proctor for completing the student information on your answer sheet. Record your answers to the Part A and Part B–1 multiple-choice questions on this separate answer sheet. Record your answers for the questions in Part B–2 and Part C in your separate answer booklet. Be sure to fill in the heading on the front of your answer booklet.

All answers in your answer booklet should be written in pen, except for graphs and drawings, which should be done in pencil. You may use scrap paper to work out the answers to the questions, but be sure to record all your answers on your separate answer sheet or in your answer booklet as directed.

When you have completed the examination, you must sign the statement printed on your separate answer sheet, indicating that you had no unlawful knowledge of the questions or answers prior to the examination and that you have neither given nor received assistance in answering any of the questions during the examination. Your answer sheet and answer booklet cannot be accepted if you fail to sign this declaration.

Notice. . .

A four-function or scientific calculator and a copy of the *2011 Edition Reference Tables for Physical Setting/Chemistry* must be available for you to use while taking this examination.

DO NOT START THIS EXAMINATION UNTIL THE SIGNAL IS GIVEN.

Part A

Answer all questions in this part.

Directions (1–30): For *each* statement or question, record on your separate answer sheet the *number* of the word or expression that, of those given, best completes the statement or answers the question. Some questions may require the use of the *2011 Edition Reference Tables for Physical Setting/Chemistry*.

1 Which statement describes a concept included in the wave-mechanical model of the atom?

- (1) Protons, neutrons, and electrons are located in the nucleus.
- (2) Electrons orbit the nucleus in shells at fixed distances.
- (3) Atoms are hard, indivisible spheres.
- (4) Electrons are located in regions called orbitals.

2 As an electron in an atom moves from a higher energy state to a lower energy state, the atom

- (1) becomes a negative ion
- (2) becomes a positive ion
- (3) releases energy
- (4) absorbs energy

3 Two atoms that are different isotopes of the same element have

- (1) the same number of protons and the same number of neutrons
- (2) the same number of protons but a different number of neutrons
- (3) a different number of protons but the same number of neutrons
- (4) a different number of protons and a different number of neutrons

4 The element in Group 14, Period 3, of the Periodic Table is classified as a

- (1) metal
- (2) noble gas
- (3) metalloid
- (4) nonmetal

5 Which element has chemical properties that are most similar to potassium?

- (1) calcium
- (2) cesium
- (3) nitrogen
- (4) sulfur

6 Which element requires the *least* amount of energy to remove the most loosely held electron from a gaseous atom in the ground state?

- (1) Na
- (2) Ar
- (3) P
- (4) Cl

7 Which terms identify two different categories of compounds?

- (1) covalent and molecular
- (2) covalent and empirical
- (3) ionic and molecular
- (4) ionic and empirical

8 Which statement describes the energy and bonding changes as two atoms of fluorine become a molecule of fluorine?

- (1) Energy is absorbed as a bond is broken.
- (2) Energy is absorbed as a bond is formed.
- (3) Energy is released as a bond is broken.
- (4) Energy is released as a bond is formed.

9 Which part of a calcium atom in the ground state is represented by the dots in its Lewis electron-dot diagram?

- (1) the electrons in the first shell
- (2) the electrons in the fourth shell
- (3) the protons in the nucleus
- (4) the neutrons in the nucleus

10 Based on Table S, an atom of which element has the strongest attraction for electrons in a chemical bond?

- (1) aluminum
- (2) chlorine
- (3) magnesium
- (4) sulfur

11 Which substance can *not* be broken down by chemical means?

- (1) aluminum
- (2) ammonia
- (3) aluminum oxide
- (4) ammonium chloride

12 Which statement describes the particles of an ideal gas, based on the kinetic molecular theory?

- (1) There are attractive forces between the particles.
- (2) The particles move in circular paths.
- (3) The collisions between the particles reduce the total energy of the gas.
- (4) The volume of the gas particles is negligible compared with the total volume of the gas.

- 13 What is the amount of heat released by 1.00 gram of liquid water at 0°C when it changes to 1.00 gram of ice at 0°C?
- (1) 4.18 J (3) 334 J
(2) 273 J (4) 2260 J
- 14 Which term identifies a type of intermolecular force?
- (1) covalent bonding (3) ionic bonding
(2) hydrogen bonding (4) metallic bonding
- 15 Which statement describes a reaction at equilibrium?
- (1) The mass of the products must equal the mass of the reactants.
(2) The entropy of the reactants must equal the entropy of the products.
(3) The rate of formation of the products must equal the rate of formation of the reactants.
(4) The number of moles of the reactants must equal the number of moles of the products.
- 16 Entropy is a measure of
- (1) accuracy
(2) precision
(3) the disorder of a system
(4) the attraction of a nucleus for an electron
- 17 Systems in nature tend to undergo changes toward
- (1) lower energy and less randomness
(2) higher energy and less randomness
(3) lower energy and greater randomness
(4) higher energy and greater randomness
- 18 Which organic prefix is matched with the number of carbon atoms that it represents?
- (1) hept-, 7 (3) pent-, 3
(2) non-, 8 (4) prop-, 4
- 19 Which terms represent two types of organic reactions?
- (1) sublimation and deposition
(2) sublimation and fermentation
(3) saponification and deposition
(4) saponification and fermentation

20 Given the organic functional group:

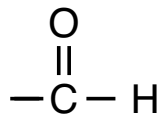

Which class of organic compounds has molecules with this functional group?

- (1) aldehydes (3) ketones
(2) esters (4) organic acids

21 Which particles are transferred during a redox reaction?

- (1) atoms (3) neutrons
(2) electrons (4) positrons

22 Which process can be represented by a half-reaction equation?

- (1) distillation (3) sublimation
(2) oxidation (4) vaporization

23 Which form of energy is converted to electrical energy in a voltaic cell?

- (1) chemical (3) nuclear
(2) mechanical (4) thermal

24 Which compound is an Arrhenius base?

- (1) HCl (3) Ca(OH)₂
(2) H₃PO₄ (4) CH₃COOH

25 In a neutralization reaction, an aqueous solution of an Arrhenius acid reacts with an aqueous solution of an Arrhenius base to produce

- (1) an ether and water
(2) an ether and an alcohol
(3) a salt and water
(4) a salt and an alcohol

26 According to one acid-base theory, a base is an

- (1) H₂ acceptor (3) H⁺ acceptor
(2) H₂ donor (4) H⁺ donor

27 Based on Table N, uranium-238 and uranium-235 have different

- (1) decay modes
(2) half-lives
(3) numbers of protons
(4) numbers of electrons

28 A change in the nucleus of an atom that converts the atom from one element to another element is called

- (1) oxidation-reduction
- (2) single replacement
- (3) substitution
- (4) transmutation

29 Which radioactive emission has the greatest penetrating power, but the *least* ionizing power?

- (1) alpha particle
- (2) beta particle
- (3) gamma ray
- (4) positron

30 Which statement describes a benefit of using fission reactions?

- (1) Radioactive waste must be stored for long periods of time.
- (2) Nuclear fuel consists of stable isotopes.
- (3) Gamma radiation is produced.
- (4) Large amounts of energy are produced per mole of reactant.

Part B–1

Answer all questions in this part.

Directions (31–50): For *each* statement or question, record on your separate answer sheet the *number* of the word or expression that, of those given, best completes the statement or answers the question. Some questions may require the use of the *2011 Edition Reference Tables for Physical Setting/Chemistry*.

31 Given the table representing the subatomic particles in four different atoms:

Atom	Number of Protons	Number of Neutrons	Number of Electrons
A	4	4	4
E	5	7	5
G	6	7	6
J	12	12	12

Which atom has a mass of 12 u?

- (1) A
- (2) E
- (3) G
- (4) J

32 Which electron configuration could represent the electrons in a sodium atom in an excited state?

- (1) 2-8
- (2) 2-8-1
- (3) 2-7-1
- (4) 2-7-2

33 What is the number of valence electrons in a nitrogen atom in the ground state?

- (1) 5
- (2) 2
- (3) 7
- (4) 14

34 Graphite and diamond are both solid forms of the element carbon. Which statement explains the different properties of these two forms of carbon?

- (1) Diamond has ionic bonding and graphite has metallic bonding.
- (2) Diamond has metallic bonding and graphite has ionic bonding.
- (3) Diamond has a different crystal structure from graphite.
- (4) Diamond has carbon atoms with more valence electrons than graphite.

35 A measured value for the atomic radius of platinum atoms was determined to be 143 picometers. Based on Table S, what is the percent error of this measured value?

- (1) 0.10% (3) 10.%
(2) 9.1% (4) 13%

36 What is the chemical formula for sodium oxalate?

- (1) NaO (3) NaC₂O₄
(2) Na₂O (4) Na₂C₂O₄

37 Given the formula of a compound:

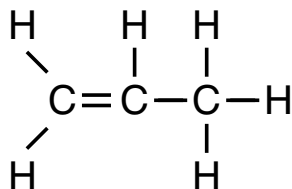

What is the molecular formula for this compound?

- (1) CH (3) CH₃
(2) CH₂ (4) C₃H₆

38 Which equation represents conservation of charge?

- (1) $\text{I}^- + 2\text{e}^- \rightarrow \text{I}_2$ (3) $\text{Br}_2 \rightarrow 2\text{Br}^- + 2\text{e}^-$
(2) $2\text{I}^- \rightarrow \text{I}_2 + 2\text{e}^-$ (4) $\text{Br} + 2\text{e}^- \rightarrow \text{Br}^-$

39 Which equation represents a single replacement reaction?

- (1) $2\text{Al}(s) + 3\text{Cl}_2(g) \rightarrow 2\text{AlCl}_3(s)$
(2) $2\text{Al}(s) + 6\text{HCl}(aq) \rightarrow 2\text{AlCl}_3(aq) + 3\text{H}_2(g)$
(3) $2\text{AlCl}_3(s) \rightarrow 2\text{Al}(s) + 3\text{Cl}_2(g)$
(4) $\text{AlCl}_3(aq) + 3\text{KOH}(aq) \rightarrow \text{Al}(\text{OH})_3(s) + 3\text{KCl}(aq)$

40 The bond between which two atoms is most polar?

- (1) C–O (3) H–O
(2) F–F (4) N–H

41 The table below shows the volume and temperature of four different gas samples at 100. kPa.

Gas Sample	Volume (L)	Temperature (°C)
helium	1	25
neon	2	50.
argon	1	25
krypton	2	25

Which two gas samples contain equal numbers of atoms?

- (1) helium and neon
- (2) helium and argon
- (3) neon and argon
- (4) neon and krypton

42 Given the equation representing a solution equilibrium:

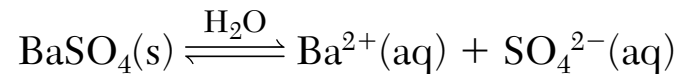

What occurs when $\text{Na}_2\text{SO}_4(\text{s})$ is added to this system, increasing the concentration of $\text{SO}_4^{2-}(\text{aq})$?

- (1) The equilibrium shifts to the left, and the concentration of $\text{Ba}^{2+}(\text{aq})$ decreases.
- (2) The equilibrium shifts to the left, and the concentration of $\text{Ba}^{2+}(\text{aq})$ increases.
- (3) The equilibrium shifts to the right, and the concentration of $\text{Ba}^{2+}(\text{aq})$ decreases.
- (4) The equilibrium shifts to the right, and the concentration of $\text{Ba}^{2+}(\text{aq})$ increases.

43 Given the formula for a compound:

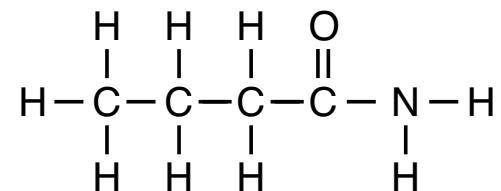

What is a chemical name for the compound?

- (1) 1-butanamine
- (2) 1-butanol
- (3) butanamide
- (4) butanoic acid

44 Given the potential energy diagram representing a reaction:

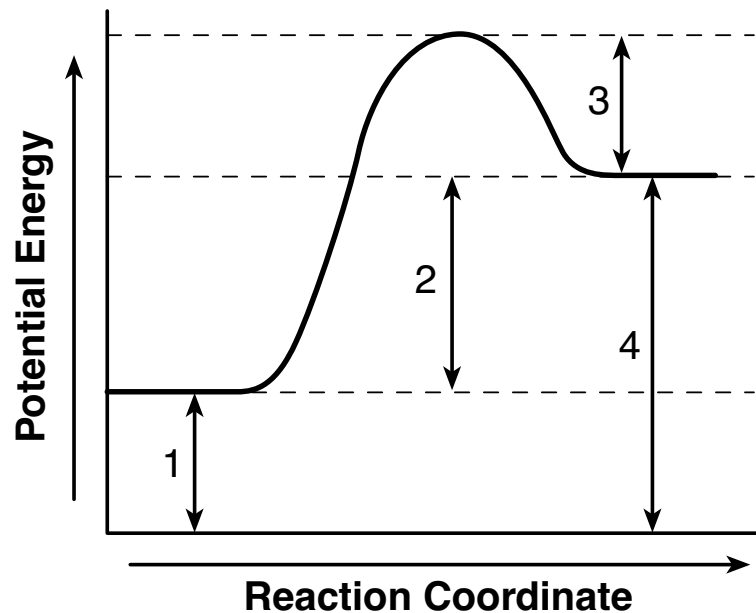

Which numbered interval represents the heat of reaction?

- | | |
|-------|-------|
| (1) 1 | (3) 3 |
| (2) 2 | (4) 4 |

45 When comparing voltaic cells to electrolytic cells, oxidation occurs at the

- (1) anode in both types of cells
- (2) cathode in both types of cells
- (3) anode in voltaic cells, only
- (4) cathode in voltaic cells, only

46 Based on Table *J*, which metal is more active than tin, but *less* active than zinc?

- | | |
|--------|--------|
| (1) Ag | (3) Cs |
| (2) Cr | (4) Mn |

47 In a titration, 10.0 mL of 0.0750 M HCl(aq) is exactly neutralized by 30.0 mL of KOH(aq) of unknown concentration. What is the concentration of the KOH(aq) solution?

- | | |
|--------------|-------------|
| (1) 0.0250 M | (3) 0.225 M |
| (2) 0.0750 M | (4) 0.333 M |

48 Which emission causes the atomic number of a nuclide to decrease by 2 and its mass number to decrease by 4?

- | | |
|-----------------------|---------------------|
| (1) an alpha particle | (3) gamma radiation |
| (2) a beta particle | (4) a positron |

49 The diagram below represents the bright-line spectra of four elements and a bright-line spectrum produced by an unidentified element.

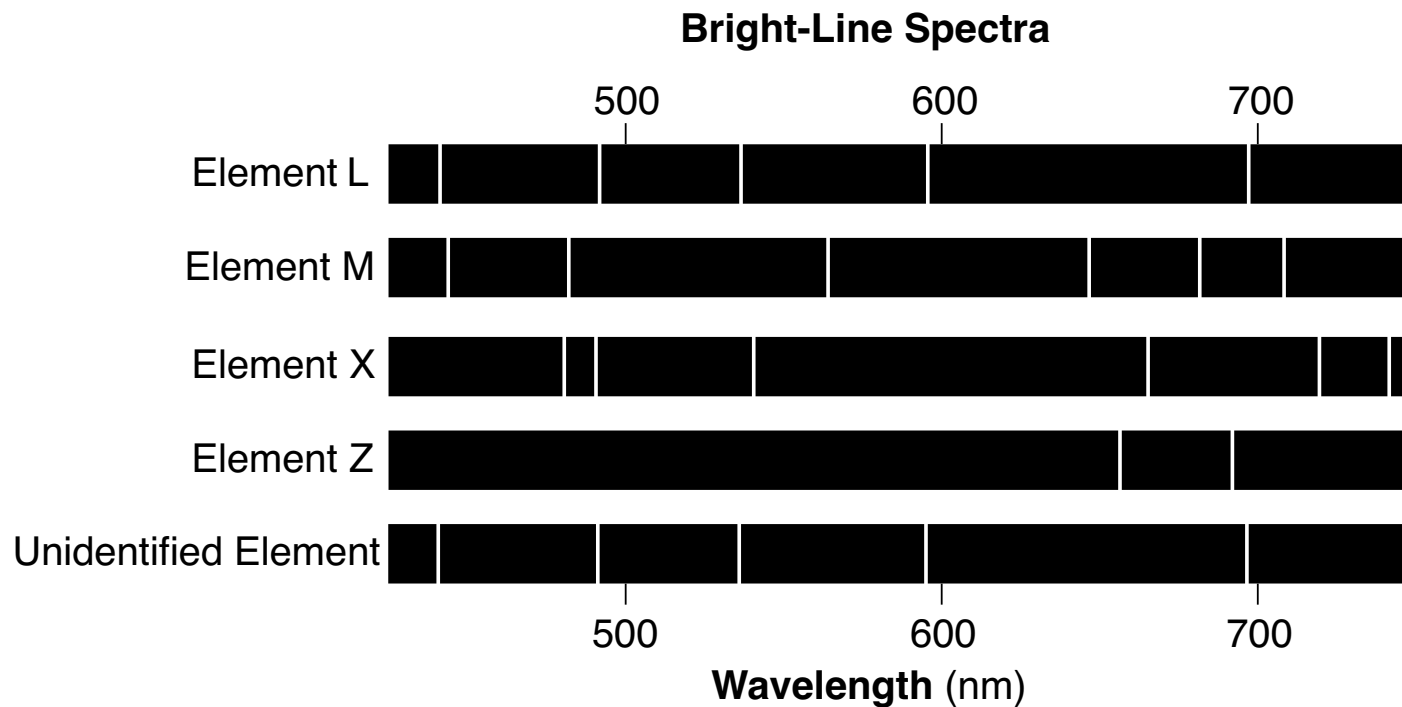

What is the unidentified element?

- (1) *L*
- (2) *M*
- (3) *X*
- (4) *Z*

50 Given two equations representing reactions:

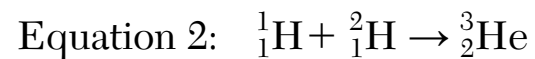
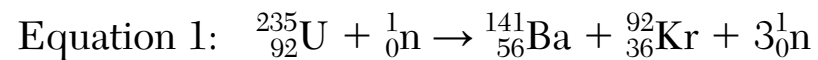

Which type of reaction is represented by each of these equations?

- (1) Both equations represent fission.
 - (2) Both equations represent fusion.
 - (3) Equation 1 represents fission and equation 2 represents fusion.
 - (4) Equation 1 represents fusion and equation 2 represents fission.
-

GO RIGHT ON TO THE NEXT PAGE ➡

Part B-2

Answer all questions in this part.

Directions (51-65): Record your answers in the spaces provided in your answer booklet. Some questions may require the use of the *2011 Edition Reference Tables for Physical Setting/Chemistry*.

Base your answers to questions 51 through 53 on the information below and on your knowledge of chemistry.

The four naturally occurring isotopes of sulfur are S-32, S-33, S-34, and S-36. The table below shows the atomic mass and percent natural abundance for these isotopes.

Naturally Occurring Isotopes of Sulfur

Isotope	Atomic Mass (u)	Natural Abundance (%)
S-32	31.972	94.99
S-33	32.971	0.75
S-34	33.968	4.25
S-36	35.967	0.01

Questions 51-53 are continued on the next page.

Questions 51-53 continued

- 51 State *both* the number of protons and the number of neutrons in an S-33 atom. [1]
- 52 In the space *in your answer booklet*, show a numerical setup for calculating the atomic mass of sulfur. [1]
- 53 Compare the energy of an electron in the third shell of a sulfur atom to the energy of an electron in the first shell of the same atom. [1]
-

GO RIGHT ON TO THE NEXT PAGE ➡

Base your answers to questions 54 through 57 on the information below and on your knowledge of chemistry.

During a laboratory activity, appropriate safety equipment is used and safety procedures are followed. A student separates a sample of rock salt that has two components; $\text{NaCl}(s)$ and small insoluble rock particles. First, the student thoroughly stirs the sample of rock salt into a sample of water in a flask. The mixture in the flask is filtered using the lab apparatus shown below.

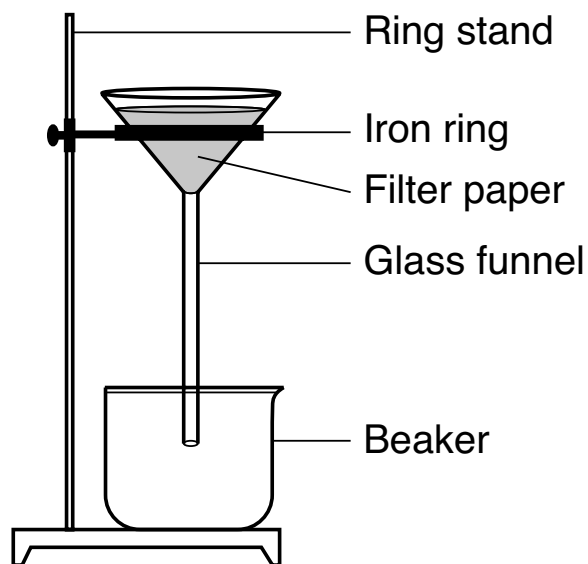

The water is evaporated from the beaker. The filter paper and its contents are dried.

Questions 54-57 are continued on the next page.

Questions 54-57 continued

The data collected by the student are shown in the table below.

Rock Salt Separation Lab Data

Object or Material	Mass (g)
rock salt sample	16.4
filter paper	1.6
clean empty beaker	224.2
filter paper with dry rock particles	2.2
beaker with dry NaCl(s)	240.0

- 54 State evidence, other than mass, from the information given that the components of rock salt have different properties. [1]
- 55 Explain, in terms of particle size, why the rock particles are trapped by the filter paper. [1]
- 56 State the number of significant figures in the mass of the beaker with dry NaCl(s). [1]
- 57 Show a numerical setup for calculating the percent by mass of NaCl in the rock salt sample. [1]

Base your answers to questions 58 through 61 on the information below and on your knowledge of chemistry.

Cylinder *A* and cylinder *B* are sealed, rigid cylinders with movable pistons. Each cylinder contains 500. milliliters of a gas sample at 101.3 kPa and 298 K. Cylinder *A* contains $\text{H}_2(\text{g})$ and cylinder *B* contains $\text{N}_2(\text{g})$. The diagrams below represent these two cylinders.

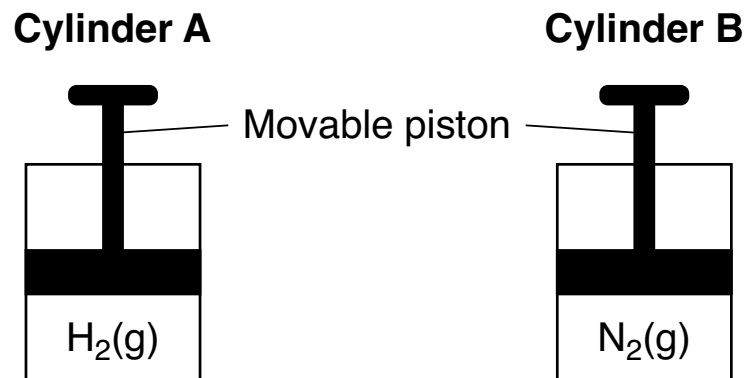

- 58 Compare the mass of the gas in cylinder *A* to the mass of the gas in cylinder *B*. [1]
- 59 State a change in temperature and a change in pressure that will cause the gas in cylinder *A* to behave more like an ideal gas. [1]
- 60 Explain, in terms of collisions between gas molecules and the walls of the container, why pushing the movable piston farther into cylinder *B* at constant temperature would increase the pressure of the N_2 gas. [1]
- 61 Show a numerical setup for calculating the volume of the gas in cylinder *B* at STP. [1]

Base your answers to questions 62 and 63 on the information below and on your knowledge of chemistry.

The electrical conductivity of three aqueous solutions was tested at room temperature. A 0.1 M HCl(aq) solution conducted, but a 6.0 M HCl(aq) solution was a better conductor. A 0.1 M C₆H₁₂O₆(aq) solution was also tested. During this laboratory activity, appropriate safety equipment was used and safety procedures were followed.

62 State, in terms of the concentration of ions, why the 6.0 M HCl(aq) is a better conductor of electricity than the 0.1 M HCl(aq). [1]

63 Identify the element in C₆H₁₂O₆ that allows it to be classified as an organic compound. [1]

Base your answers to questions 64 and 65 on the information below and on your knowledge of chemistry.

Phosphorus-30 and phosphorus-32 are radioisotopes. Phosphorus-30 decays by positron emission.

64 Complete the equation *in your answer booklet* for the decay of phosphorus-30 by writing a notation for the missing product. [1]

65 Based on Table N, determine the time required for an original 100.-milligram sample of P-32 to decay until only 25 milligrams of the sample remain unchanged. [1]

Part C

Answer all questions in this part.

Directions (66-85): Record your answers in the spaces provided in your answer booklet. Some questions may require the use of the *2011 Edition Reference Tables for Physical Setting/Chemistry*.

Base your answers to questions 66 through 69 on the information below and on your knowledge of chemistry.

Sir William Ramsey is one scientist credited with identifying the noble gas argon. Sir Ramsey separated nitrogen gas from the air and reacted it with an excess of magnesium, producing solid magnesium nitride. However, a small sample of an unreactive gas remained with a density different from the density of the nitrogen gas. Sir Ramsey identified the unreactive gas as argon and later went on to discover neon, krypton, and xenon.

- 66 Compare the chemical reactivities of nitrogen gas and argon gas based on Sir Ramsey's experiment using magnesium. [1]
- 67 Compare the density of nitrogen gas to the density of argon gas when both gases are at 298 K and 101.3 kPa. [1]
- 68 State, in terms of valence electrons, why the noble gases that Sir Ramsey discovered have similar chemical properties. [1]
- 69 State the trend, at standard pressure, of the boiling points of these noble gases, as they are considered in order of increasing atomic number. [1]

Base your answers to questions 70 through 72 on the information below and on your knowledge of chemistry.

A sample of normal rainwater has a pH value of 5.6 due to dissolved carbon dioxide gas from the atmosphere. Acid rain is formed when other gases, such as sulfur dioxide, dissolve in rainwater, which can result in lake water with a pH value of 4.6. The equation below represents the reaction of water with $\text{SO}_2(\text{g})$.

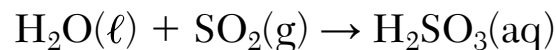

- 70 State how many times greater the hydronium ion concentration in the lake water is than the hydronium concentration in the sample of normal rainwater. [1]
- 71 State the color of methyl orange in a sample of normal rainwater. [1]
- 72 Based on Table G, describe what happens to the solubility of $\text{SO}_2(\text{g})$ as the temperature increases from $10.^{\circ}\text{C}$ to $30.^{\circ}\text{C}$ at standard pressure. [1]
-

GO RIGHT ON TO THE NEXT PAGE ➡

Base your answers to questions 73 through 77 on the information below and on your knowledge of chemistry.

A metal worker uses a cutting torch that operates by reacting acetylene gas, $\text{C}_2\text{H}_2(\text{g})$, with oxygen gas, $\text{O}_2(\text{g})$, as shown in the unbalanced equation below.



- 73 Write the empirical formula for acetylene. [1]
- 74 *In your answer booklet*, use the key to draw a particle model diagram to represent the phase of the $\text{O}_2(\text{g})$. Your response must include *at least six* molecules. [1]
- 75 Balance the equation *in your answer booklet* for the reaction of acetylene and oxygen, using the smallest whole-number coefficients. [1]
- 76 Determine the mass of 25 moles of acetylene (gram-formula mass = 26 g/mol). [1]
- 77 Explain, in terms of bonding, why the hydrocarbon gas used in the cutting torch is classified as an alkyne. [1]
-

Base your answers to questions 78 through 82 on the information below and on your knowledge of chemistry.

Water, H_2O , and hexane, C_6H_{14} , are commonly used as laboratory solvents because they have different physical properties and are able to dissolve different types of solutes. Some physical properties of water and hexane are listed on the table below.

Physical Properties of H_2O and C_6H_{14}

Solvent	Boiling Point (°C)	Melting Point (°C)	Vapor Pressure at 69°C (kPa)
H_2O	100.	0.	?
C_6H_{14}	69	-95	101.3

- 78 Compare the thermal energy of a 10.-gram sample of water at 25°C to the thermal energy of a 1000.-gram sample of water at 25°C . [1]
- 79 State what happens to the potential energy of the molecules in a solid sample of hexane at -95°C as heat is added until the hexane is completely melted. [1]
- 80 Determine the vapor pressure of water at 69°C . [1]
- 81 Explain, in terms of the molecular polarity, why hexane is nearly insoluble in water. [1]
- 82 Explain, in terms of molecular formulas and structural formulas, why 2,2-dimethylbutane is an isomer of hexane. [1]

Base your answers to questions 83 through 85 on the information below and on your knowledge of chemistry.

In a laboratory investigation, a student constructs an electrochemical cell to decompose water, as represented in the diagram below. The water in the electrochemical cell contains a small amount of dissolved sodium sulfate, to increase conductivity. The three equations represent the reaction in each test tube and the overall reaction. During this laboratory activity, appropriate safety equipment is used and safety procedures are followed.

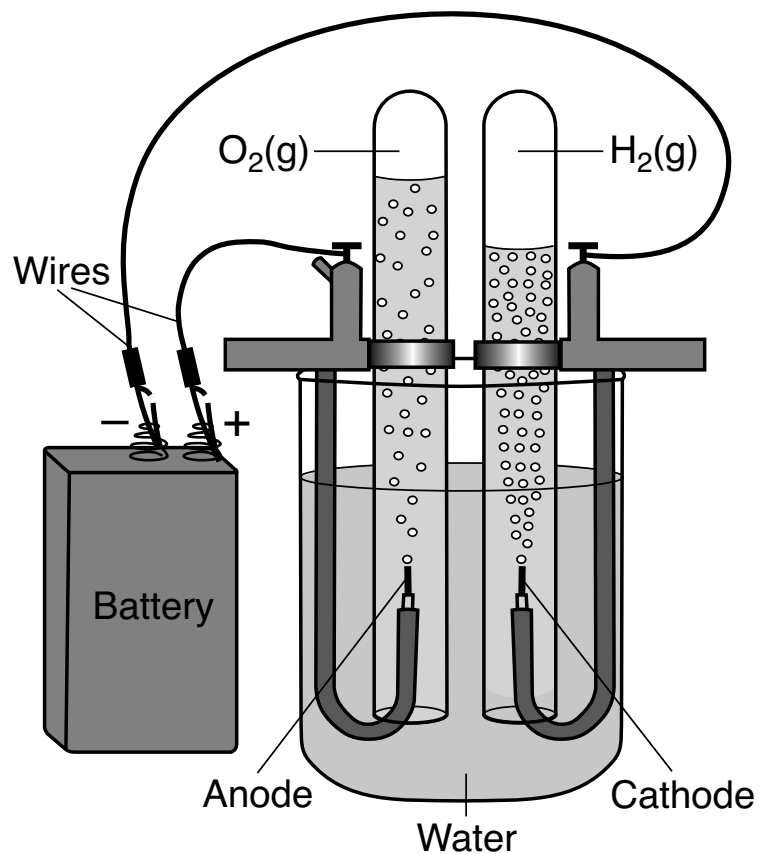

Questions 83-85 are continued on the next page.

Questions 83-85 continued

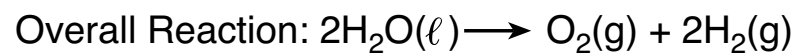
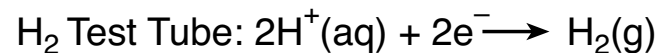
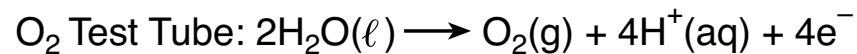

- 83 State the change in oxidation number that occurs for oxygen in the overall reaction. [1]
- 84 Compare the number of electrons lost by oxygen to the number of electrons gained by hydrogen in the overall reaction. [1]
- 85 Determine the number of moles of hydrogen gas produced when 0.0004 mole of oxygen gas is produced in the cell by the overall reaction. [1]
-

