

Large-Type Edition

The University of the State of New York
REGENTS HIGH SCHOOL EXAMINATION

PHYSICAL SETTING CHEMISTRY

Friday, June 16, 2023 — 1:15 to 4:15 p.m., only

The possession or use of any communications device is strictly prohibited when taking this examination. If you have or use any communications device, no matter how briefly, your examination will be invalidated and no score will be calculated for you.

This is a test of your knowledge of chemistry. Use that knowledge to answer all questions in this examination. Some questions may require the use of the *2011 Edition Reference Tables for Physical Setting/Chemistry*. You are to answer *all* questions in all parts of this examination according to the directions provided in this examination booklet.

A separate answer sheet for Part A and Part B–1 has been provided to you. Follow the instructions from the proctor for completing the student information on your answer sheet. Record your answers to the Part A and Part B–1 multiple-choice questions on this separate answer sheet. Record your answers for the questions in Part B–2 and Part C in your separate answer booklet. Be sure to fill in the heading on the front of your answer booklet.

All answers in your answer booklet should be written in pen, except for graphs and drawings, which should be done in pencil. You may use scrap paper to work out the answers to the questions, but be sure to record all your answers on your separate answer sheet or in your answer booklet as directed.

When you have completed the examination, you must sign the statement printed on your separate answer sheet, indicating that you had no unlawful knowledge of the questions or answers prior to the examination and that you have neither given nor received assistance in answering any of the questions during the examination. Your answer sheet and answer booklet cannot be accepted if you fail to sign this declaration.

Notice. . .

A four-function or scientific calculator and a copy of the *2011 Edition Reference Tables for Physical Setting/Chemistry* must be available for you to use while taking this examination.

DO NOT START THIS EXAMINATION UNTIL THE SIGNAL IS GIVEN.

Part A

Answer all questions in this part.

Directions (1–30): For *each* statement or question, record on your separate answer sheet the *number* of the word or expression that, of those given, best completes the statement or answers the question. Some questions may require the use of the *2011 Edition Reference Tables for Physical Setting/Chemistry*.

1 Which phrase describes the nucleus of any atom?

- (1) has an overall positive charge
- (2) has an overall negative charge
- (3) contains negative electrons
- (4) contains positive electrons

2 Which two particles each have a mass of approximately one atomic mass unit?

- (1) an electron and a proton
- (2) an electron and a positron
- (3) a neutron and a proton
- (4) a neutron and a positron

3 The wave-mechanical model of the atom describes the location of electrons

- (1) as loosely packed in the nucleus of an atom
- (2) as densely packed in the nucleus of an atom
- (3) in circular paths around the nucleus
- (4) in orbitals outside the nucleus

4 When a ground state electron in an atom moves to an excited state, the electron

- (1) absorbs energy as it moves to a higher energy state
- (2) absorbs energy as it moves to a lower energy state
- (3) releases energy as it moves to a higher energy state
- (4) releases energy as it moves to a lower energy state

5 Which statement describes a chemical property of iron?

- (1) Iron is malleable.
- (2) Iron conducts electricity.
- (3) Iron reacts with nitric acid.
- (4) Iron has a high melting point.

6 Diamond and graphite are two forms of solid carbon. These two forms of carbon have

- (1) different crystal structures and different properties
- (2) different crystal structures and the same properties
- (3) the same crystal structure and different properties
- (4) the same crystal structure and the same properties

7 Which substance can be broken down by a chemical change?

- (1) cobalt
- (2) ethane
- (3) krypton
- (4) manganese

8 Based on Table I, which equation represents conservation of mass and energy?

- (1) $\text{CH}_4(\text{g}) + \text{O}_2(\text{g}) + 890.4 \text{ kJ} \rightarrow \text{CO}_2(\text{g}) + \text{H}_2\text{O}(\ell)$
- (2) $\text{CH}_4(\text{g}) + \text{O}_2(\text{g}) \rightarrow \text{CO}_2(\text{g}) + \text{H}_2\text{O}(\ell) + 890.4 \text{ kJ}$
- (3) $\text{CH}_4(\text{g}) + 2\text{O}_2(\text{g}) + 890.4 \text{ kJ} \rightarrow \text{CO}_2(\text{g}) + 2\text{H}_2\text{O}(\ell)$
- (4) $\text{CH}_4(\text{g}) + 2\text{O}_2(\text{g}) \rightarrow \text{CO}_2(\text{g}) + 2\text{H}_2\text{O}(\ell) + 890.4 \text{ kJ}$

9 At STP, which property can be used to differentiate a 10.-gram sample of $\text{NaCl}(\text{s})$ from a 10.-gram sample of $\text{NaNO}_3(\text{s})$?

- (1) mass of the sample
- (2) temperature of the sample
- (3) solubility in water
- (4) phase at STP

10 What is the number of electrons shared between the two atoms in an O_2 molecule?

- (1) 6
- (2) 2
- (3) 3
- (4) 4

11 Which changes in *both* charge and radius occur when an atom loses an electron?

- (1) A negative ion is formed with a smaller radius than the atom.
- (2) A negative ion is formed with a larger radius than the atom.
- (3) A positive ion is formed with a smaller radius than the atom.
- (4) A positive ion is formed with a larger radius than the atom.

12 Which statement describes what occurs when two iodine atoms react to produce an iodine molecule?

- (1) A bond forms and energy is absorbed.
- (2) A bond forms and energy is released.
- (3) A bond breaks and energy is absorbed.
- (4) A bond breaks and energy is released.

13 Which process can be used to separate a mixture of two liquids having different boiling points?

- (1) deposition
- (2) distillation
- (3) filtration
- (4) sublimation

14 Which statement describes a solution of sodium chloride in water?

- (1) The mixture is heterogeneous, the solute is NaCl and the solvent is H₂O.
- (2) The mixture is heterogeneous, the solute is H₂O and the solvent is NaCl.
- (3) The mixture is homogeneous, the solute is NaCl and the solvent is H₂O.
- (4) The mixture is homogeneous, the solute is H₂O and the solvent is NaCl.

15 At STP, which property would be the same for 1.0 liter of helium and 1.0 liter of argon?

- (1) boiling point
- (2) density
- (3) mass
- (4) number of atoms

16 The melting of an ice cube is an example of an

- (1) endothermic, chemical change
- (2) endothermic, physical change
- (3) exothermic, chemical change
- (4) exothermic, physical change

17 Which statement explains the low boiling point of hydrogen, H_2 , at standard pressure?

- (1) Hydrogen has strong covalent bonds.
- (2) Hydrogen has weak covalent bonds.
- (3) Hydrogen has strong intermolecular forces.
- (4) Hydrogen has weak intermolecular forces.

18 In chemical reactions, which term is defined as the difference between the potential energy of the products and the potential energy of the reactants?

- (1) heat of fusion
- (2) heat of reaction
- (3) thermal conductivity
- (4) electrical conductivity

19 Which phrase describes what happens to the reaction pathway and activation energy of a reaction to which a catalyst is added?

- (1) the same pathway with the same activation energy
- (2) the same pathway with a lower activation energy
- (3) a different pathway with the same activation energy
- (4) a different pathway with a lower activation energy

20 An atom of which element is bonded to the carbon atom in the amide functional group?

- (1) iodine
- (2) nitrogen
- (3) phosphorus
- (4) sulfur

21 Which statement describes the two isomers of butane?

- (1) They have the same molecular formula but different structural formulas.
- (2) They have the same molecular formula and the same structural formula.
- (3) They have different molecular formulas and different structural formulas.
- (4) They have different molecular formulas but the same structural formula.

22 Which term represents an organic reaction that produces soap?

- (1) esterification
- (2) fermentation
- (3) saponification
- (4) solidification

23 In which part of an electrochemical cell does reduction occur?

- (1) anode
- (2) cathode
- (3) wire
- (4) voltmeter

24 Which energy change occurs in an operating voltaic cell?

- (1) chemical energy to electrical energy
- (2) chemical energy to nuclear energy
- (3) electrical energy to chemical energy
- (4) electrical energy to nuclear energy

25 Which substance is an Arrhenius base?

- (1) HNO_3
- (2) KNO_3
- (3) LiOH
- (4) CH_3COOH

26 Which statement represents neutralization?

- (1) An Arrhenius acid and an Arrhenius base react to produce water and a salt.
- (2) An Arrhenius acid and a salt react to produce water and an Arrhenius base.
- (3) Water and an Arrhenius acid react to produce an Arrhenius base and a salt.
- (4) Water and a salt react to produce an Arrhenius base and an Arrhenius acid.

27 A tenfold increase in hydronium ion concentration is represented by

- (1) a decrease of one unit of pH
- (2) a decrease of 10 units of pH
- (3) an increase of one unit of pH
- (4) an increase of 10 units of pH

28 Based on Table N, which particle is emitted by the radioactive decay of francium-220?

- (1) an alpha particle
- (2) a beta particle
- (3) a positron
- (4) a neutron

29 Which type of reaction releases the greatest amount of energy per kilogram of reactant?

- (1) acid-base reaction
- (2) fission reaction
- (3) organic reaction
- (4) redox reaction

30 Which risk is related to the radioactive isotopes used to generate electricity?

- (1) depletion of fossil fuels
- (2) depletion of atmospheric ozone
- (3) exposure to acid rain
- (4) exposure to nuclear emissions

Part B-1

Answer all questions in this part.

Directions (31–50): For *each* statement or question, record on your separate answer sheet the *number* of the word or expression that, of those given, best completes the statement or answers the question. Some questions may require the use of the *2011 Edition Reference Tables for Physical Setting/Chemistry*.

31 Which Lewis electron-dot diagram represents an atom of nitrogen in the ground state?



(1)



(2)



(3)



(4)

32 The atomic masses and natural abundances of the two naturally occurring isotopes of silver are shown in the table below.

Silver Isotopes

Isotope	Atomic Mass (u)	Natural Abundance (%)
Ag-107	106.905	51.8
Ag-109	108.905	48.2

Which numerical setup can be used to calculate the atomic mass of silver?

- (1) $(106.905 \text{ u})(51.8) + (108.905 \text{ u})(48.2)$
- (2) $(106.905 \text{ u})(51.8\%) + (108.905 \text{ u})(48.2\%)$
- (3) $(106.905 \text{ u})(48.2) + (108.905 \text{ u})(51.8)$
- (4) $(106.905 \text{ u})(48.2\%) + (108.905 \text{ u})(51.8\%)$

33 A potassium atom has a mass number of 37. What is the number of neutrons in this atom?

- (1) 15 (3) 22
(2) 18 (4) 37

34 At room temperature, a student determines the density of a sample of nickel to be 9.79 g/cm^3 . Based on Table S, what is the student's percent error for the density of nickel?

- (1) 0.091% (3) 9.1%
(2) 0.10% (4) 10.0%

35 Compared to the metals in Period 2, the nonmetals in Period 2 have

- (1) lower first ionization energies and lower electronegativity values
(2) lower first ionization energies and higher electronegativity values
(3) higher first ionization energies and lower electronegativity values
(4) higher first ionization energies and higher electronegativity values

36 Which formula represents calcium hydride?

- (1) CaH (3) CaOH
(2) CaH₂ (4) Ca(OH)₂

37 What is the number of moles in a 78.8-gram sample of MgCO₃ (gram-formula mass = 84.3 g/mol)?

- (1) 0.949 mol (3) 0.843 mol
(2) 0.935 mol (4) 1.070 mol

38 Given the equation representing a reaction:

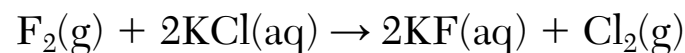

Which type of chemical reaction is represented by the equation?

- (1) synthesis
(2) decomposition
(3) single replacement
(4) double replacement

39 Based on Table H, which compound has the strongest intermolecular forces at 60 kPa?

- (1) ethanoic acid (3) propanone
(2) ethanol (4) water

40 Which particle diagram represents a sample of xenon at STP?

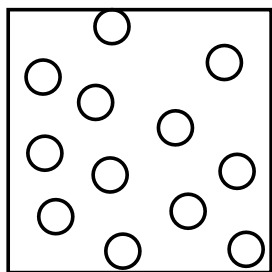
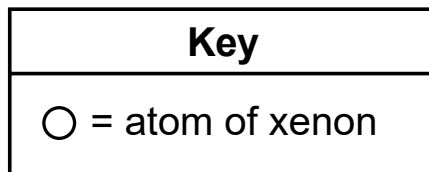

(1)

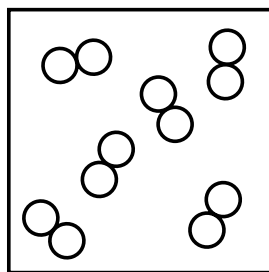

(3)

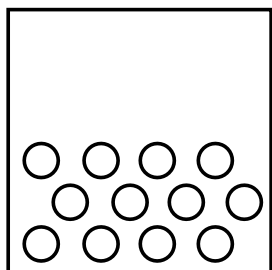

(2)

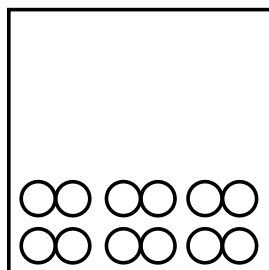

(4)

41 Based on Table G, which compound is *less* soluble in water as the temperature increases from 0°C to 100°C?



42 How many moles of KI are needed to make 0.50 L of a 0.20 M aqueous solution?

(1) 0.10 mol

(2) 0.25 mol

(3) 0.40 mol

(4) 0.70 mol

43 A solution is prepared using 9.80 grams of NaHCO_3 in enough water to make 1500. grams of total solution. What is the concentration of the solution expressed in parts per million?

(1) 6.49×10^{-3} ppm

(2) 6.53×10^{-3} ppm

(3) 6.49×10^3 ppm

(4) 6.53×10^3 ppm

44 A potential energy diagram for a chemical reaction is given below. Each interval on the potential energy axis represents 100. kilojoules of potential energy.

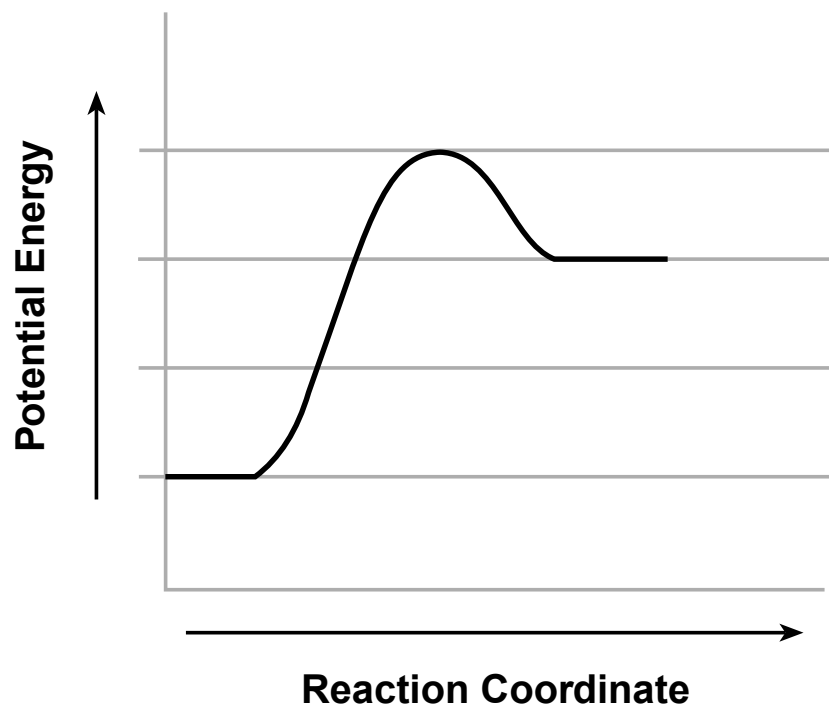

What can be concluded from the diagram?

- (1) The reaction is endothermic, and the heat of reaction is $-200.$ kJ.
- (2) The reaction is endothermic, and the heat of reaction is $+200.$ kJ.
- (3) The reaction is exothermic, and the heat of reaction is $-200.$ kJ.
- (4) The reaction is exothermic, and the heat of reaction is $+200.$ kJ.

45 Given the formula representing a compound:

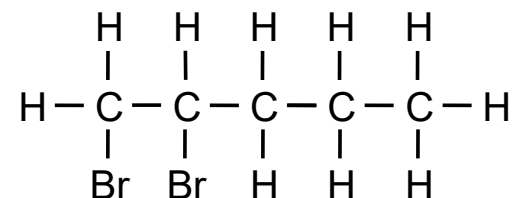

What is a chemical name of this compound?

- (1) 1,1-dibromopentane
- (2) 2,2-dibromopentane
- (3) 1,2-dibromopentane
- (4) 4,5-dibromopentane

46 The diagram and equation below represent an electrochemical cell.

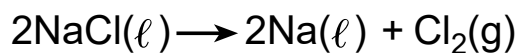
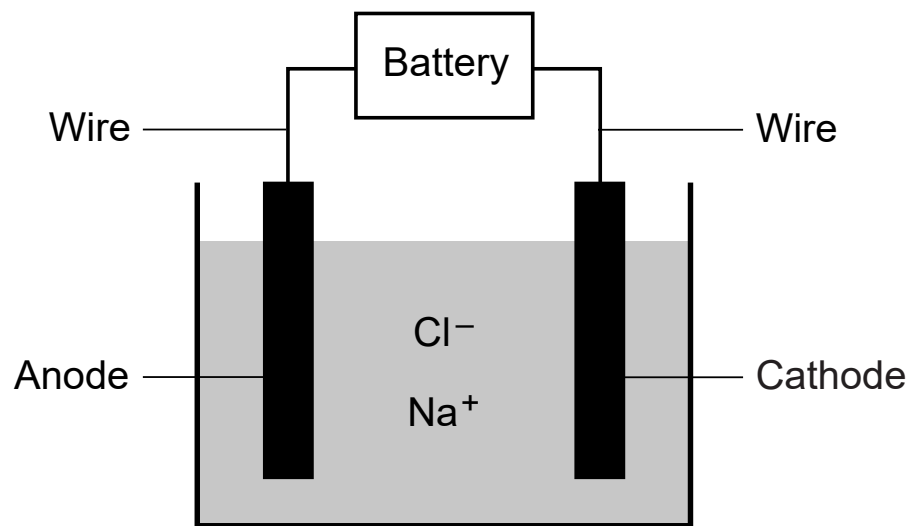

Which process is represented by this diagram?

- (1) chromatography (3) electrolysis
 (2) distillation (4) polymerization

47 Which aqueous solution has the greatest ability to conduct an electric current?

- (1) 0.10 M NaCl(aq)
 (2) 0.010 M NaCl(aq)
 (3) 0.10 M $\text{C}_6\text{H}_{12}\text{O}_6$ (aq)
 (4) 0.010 M $\text{C}_6\text{H}_{12}\text{O}_6$ (aq)

48 What fraction of an original sample of ^{131}I remains unchanged after 24.063 days?

- (1) 1/8 (3) 1/3
 (2) 1/2 (4) 1/4

49 Given the equation representing a reaction:



Which type of reaction is represented by the equation?

- (1) nuclear fission (3) combustion
 (2) nuclear fusion (4) substitution

50 Given the nuclear equation and isotopic masses:

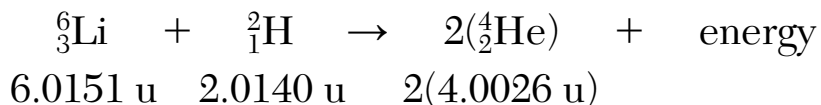

What is the amount of mass converted to energy as a result of the reaction between the two reactant nuclei?

- (1) 0.0239 u (3) 8.0052 u
 (2) 4.0265 u (4) 16.0343 u

Part B-2

Answer all questions in this part.

Directions (51-65): Record your answers in the spaces provided in your answer booklet. Some questions may require the use of the *2011 Edition Reference Tables for Physical Setting/Chemistry*.

Base your answers to questions 51 and 52 on the information below and on your knowledge of chemistry.

The element technetium, Tc, has several isotopes. The bright-line spectrum of technetium has been observed in the spectra of some stars.

- 51 Compare the energy of an electron in the first shell of a technetium atom to the energy of an electron in the third shell of the same atom. [1]
- 52 State, in terms of protons and neutrons, why the various nuclides of technetium are isotopes of each other. [1]
-

Base your answers to questions 53 and 54 on the information below and on your knowledge of chemistry.

A sample of a gas in a sealed, rigid cylinder with a movable piston has a volume of 0.250 liter at STP.

53 Show a numerical setup for calculating the volume of this sample of gas at 298 K and 1.00 atm. [1]

54 State a change in pressure that will cause the gas in the cylinder to behave more like an ideal gas. [1]

GO RIGHT ON TO THE NEXT PAGE \Rightarrow

Base your answers to questions 55 through 57 on the information below and on your knowledge of chemistry.

During a laboratory activity, a student heats a beaker containing 120.0 grams of water as shown in the diagram below.

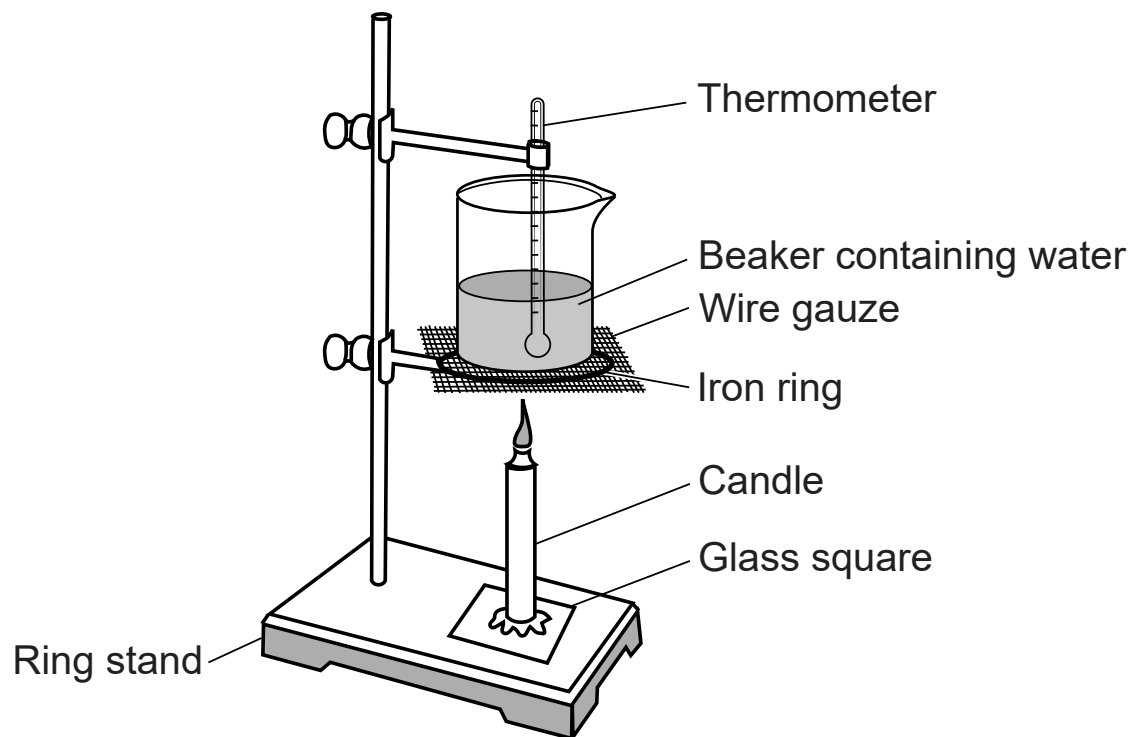

The table below shows the mass of the water and the temperature of the water before and after heating. During this laboratory activity, appropriate safety equipment is used and safety procedures are followed.

Data for Heating Water

Mass of 120.0 mL of water	120.0 g
Temperature of water before heating	23.0°C
Temperature of water after heating 20.0 min	86.0°C

- 55 State the direction of heat flow between the candle flame and the beaker of water during the time the candle is lit. [1]
- 56 Show a numerical setup for calculating the amount of heat, in joules, absorbed by the water in the beaker as a result of the burning candle. [1]
- 57 State how the molecular motion of the water molecules in the beaker changes as the temperature increases. [1]
-

GO RIGHT ON TO THE NEXT PAGE ⇒

Base your answers to questions 58 through 60 on the information below and on your knowledge of chemistry.

Nitrogen dioxide gas, $\text{NO}_2(\text{g})$, can reach equilibrium with dinitrogen tetroxide gas, $\text{N}_2\text{O}_4(\text{g})$, in a closed system. At 1.0 atmosphere, the boiling point of N_2O_4 is 21°C . The equation below represents this system.

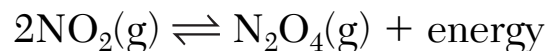

- 58 Compare the rate of the forward reaction to the rate of the reverse reaction when the system is at equilibrium. [1]
- 59 State how the equilibrium shifts when the pressure on the equilibrium system is increased at constant temperature. [1]
- 60 Compare the entropy of a sample of dinitrogen tetroxide gas at 25°C and 1.0 atmosphere to the entropy of the same sample of dinitrogen tetroxide liquid at 15°C and 1.0 atmosphere. [1]
-

Base your answers to questions 61 through 63 on the information below and on your knowledge of chemistry.

When solid copper is placed in an aqueous silver nitrate solution, a reaction occurs, as represented by the equation below.

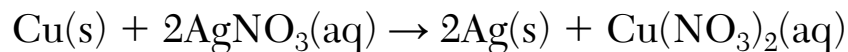

- 61 State the change in oxidation state of copper in this reaction. [1]
- 62 Based on Table *J*, state why Cu(s) reacts spontaneously with $\text{Ag}^+(\text{aq})$. [1]
- 63 Write a balanced half-reaction equation to represent the reduction of the silver ions to silver atoms. [1]
-

Base your answers to questions 64 and 65 on the information below and on your knowledge of chemistry.

During a laboratory activity, 15.0 mL of hydrochloric acid, HCl(aq) , is exactly neutralized by 18.2 mL of 0.11 M sodium hydroxide, NaOH(aq) . During the laboratory activity, appropriate safety equipment is used and safety procedures are followed.

- 64 Write the name of the laboratory procedure used in this activity. [1]
- 65 Show a numerical setup for calculating the molarity of the HCl(aq) solution. [1]
-

Part C

Answer all questions in this part.

Directions (66-85): Record your answers in the spaces provided in your answer booklet. Some questions may require the use of the *2011 Edition Reference Tables for Physical Setting/Chemistry*.

Base your answers to questions 66 through 69 on the information below and on your knowledge of chemistry.

Several elements are considered endangered because there is a risk of these elements becoming unavailable for commercial uses in the next 100 years. Helium, zinc, gallium, indium, and tellurium are included in the list of these endangered elements.

- 66 Identify the *three* endangered elements listed in the passage that are classified as metals. [1]
- 67 Explain, in terms of electrons, why gallium and indium have similar chemical properties. [1]
- 68 Compare the density of a sample of helium at STP with the density of a sample of tellurium at STP. [1]
- 69 Explain, in terms of electron shells, why the atomic radius of an atom of indium is greater than the atomic radius of an atom of gallium when both atoms are in the ground state. [1]
-

Base your answers to questions 70 through 73 on the information below and on your knowledge of chemistry.

The Ostwald process is an industrial method to produce nitric acid, $\text{HNO}_3(\text{aq})$, used in the manufacture of fertilizers. Several steps are involved in this process. In the first step, ammonia and oxygen react in the presence of a catalyst, as represented by unbalanced equation 1.

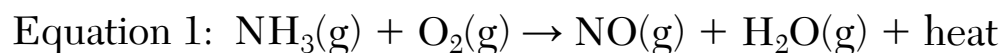

In the second step, nitrogen(II) oxide reacts with oxygen to produce nitrogen(IV) oxide, represented by balanced equation 2 below.



- 70 Determine the percent composition by mass of nitrogen in HNO_3 (gram-formula mass = 63.0 g/mol). [1]
- 71 Balance equation 1 *in your answer booklet*, using the smallest whole-number coefficients. [1]
- 72 Show a numerical setup for calculating the gram-formula mass of the $\text{NO}_2(\text{g})$ produced in equation 2. [1]
- 73 Determine the number of moles of oxygen required to completely react with 4.0 moles of $\text{NO}(\text{g})$ in equation 2. [1]
-

Base your answers to questions 74 through 78 on the information below and on your knowledge of chemistry.

As plants grow, light energy is converted into chemical energy during the process of photosynthesis. The reaction produces glucose and oxygen. The balanced equation below represents photosynthesis.



- 74 State the molecular polarity for each of the reactants in the equation. [1]
- 75 In the space *in your answer booklet*, draw a Lewis electron-dot diagram for a molecule of water. [1]
- 76 Based on Table S, compare the strength of attraction of a carbon atom for electrons with the strength of attraction of an oxygen atom for the electrons in a bond between them. [1]
- 77 State, in terms of element classification, why CO_2 is a molecular compound. [1]
- 78 Write the empirical formula for glucose. [1]
-

Base your answers to questions 79 through 81 on the information below and on your knowledge of chemistry.

In the United States, nearly all fuel for automobiles is a mixture of gasoline and ethanol, C_2H_5OH . The equation below represents a reaction between ethene and water to produce ethanol.

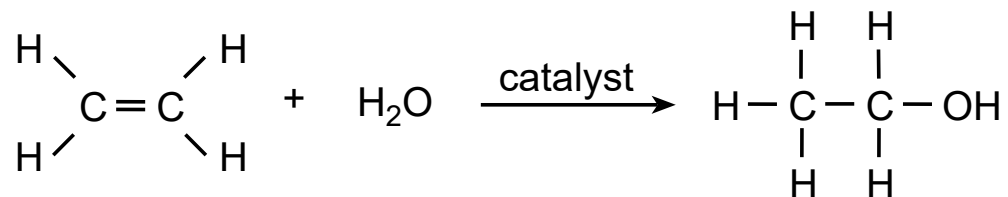

- 79 State the class of organic compound to which the product in the equation belongs. [1]
- 80 State, in terms of carbon-to-carbon bonds, why the hydrocarbon in the equation is unsaturated. [1]
- 81 Identify the element in the product of the reaction that allows it to be classified as an organic compound. [1]
-

Base your answers to questions 82 through 85 on the information below and on your knowledge of chemistry.

In a laboratory activity, a student measures the pH values of four household liquids and distilled water, as shown in the table below. During this laboratory activity, appropriate safety equipment is used and safety procedures are followed.

Measured pH Value of Liquids Tested

Liquid Tested	Measured pH Value
aqueous ammonia	11.9
black coffee	4.9
lemon juice	2.1
vinegar	3.3
distilled water	7.0

- 82 Identify the liquid tested by the student that is most acidic. [1]
- 83 State the color of bromcresol green after the indicator is added to a sample of lemon juice. [1]
- 84 Complete the equation *in your answer booklet* by writing the formula of the missing product in the reaction of aqueous potassium hydroxide with the vinegar, acetic acid. [1]
- 85 Based on the pH value in the table, compare the concentration of hydronium ions to the concentration of hydroxide ions in the distilled water. [1]
-

