

The University of the State of New York  
REGENTS HIGH SCHOOL EXAMINATION

**PHYSICAL SETTING  
CHEMISTRY**

**Tuesday, August 13, 2019 — 8:30 to 11:30 a.m., only**

The possession or use of any communications device is strictly prohibited when taking this examination. If you have or use any communications device, no matter how briefly, your examination will be invalidated and no score will be calculated for you.

This is a test of your knowledge of chemistry. Use that knowledge to answer all questions in this examination. Some questions may require the use of the *2011 Edition Reference Tables for Physical Setting/Chemistry*. You are to answer *all* questions in all parts of this examination according to the directions provided in this examination booklet.

A separate answer sheet for Part A and Part B–1 has been provided to you. Follow the instructions from the proctor for completing the student information on your answer sheet. Record your answers to the Part A and Part B–1 multiple-choice questions on this separate answer sheet. Record your answers for the questions in Part B–2 and Part C in your separate answer booklet. Be sure to fill in the heading on the front of your answer booklet.

All answers in your answer booklet should be written in pen, except for graphs and drawings, which should be done in pencil. You may use scrap paper to work out the answers to the questions, but be sure to record all your answers on your separate answer sheet or in your answer booklet as directed.

When you have completed the examination, you must sign the statement printed on your separate answer sheet, indicating that you had no unlawful knowledge of the questions or answers prior to the examination and that you have neither given nor received assistance in answering any of the questions during the examination. Your answer sheet and answer booklet cannot be accepted if you fail to sign this declaration.

Notice . . .

A four-function or scientific calculator and a copy of the *2011 Edition Reference Tables for Physical Setting/Chemistry* must be available for you to use while taking this examination.

**DO NOT OPEN THIS EXAMINATION BOOKLET UNTIL THE SIGNAL IS GIVEN.**

## Part A

### Answer all questions in this part.

*Directions (1–30):* For *each* statement or question, record on your separate answer sheet the *number* of the word or expression that, of those given, best completes the statement or answers the question. Some questions may require the use of the *2011 Edition Reference Tables for Physical Setting/Chemistry*.

- Which statement describes the earliest model of the atom?
  - An atom is an indivisible hard sphere.
  - An atom has a small, dense nucleus.
  - Electrons are negative particles in an atom.
  - Electrons in an atom have wave-like properties.
- In all atoms of bismuth, the number of electrons must equal the
  - number of protons
  - number of neutrons
  - sum of the number of neutrons and protons
  - difference between the number of neutrons and protons
- Which symbol represents a particle that has a mass approximately equal to the mass of a neutron?
  - $\alpha$
  - $\beta^+$
  - $\beta^-$
  - p
- An orbital is a region in an atom where there is a high probability of finding
  - an alpha particle
  - an electron
  - a neutron
  - a positron
- Which electron shell in an atom of calcium in the ground state has an electron with the greatest amount of energy?
  - 1
  - 2
  - 3
  - 4
- As the elements in Period 2 are considered in order from lithium to fluorine, there is an increase in the
  - atomic radius
  - electronegativity
  - number of electron shells
  - number of electrons in the first shell
- Which element is classified as a metalloid?
  - boron
  - potassium
  - sulfur
  - xenon
- Strontium and barium have similar chemical properties because atoms of these elements have the same number of
  - protons
  - neutrons
  - electron shells
  - valence electrons
- Which term represents the fixed proportion of elements in a compound?
  - atomic mass
  - molar mass
  - chemical formula
  - density formula
- Which two terms represent types of chemical formulas?
  - mechanical and structural
  - mechanical and thermal
  - molecular and structural
  - molecular and thermal
- Which element has metallic bonds at room temperature?
  - bromine
  - cesium
  - krypton
  - sulfur

- 12 What is the number of electrons shared between the atoms in a molecule of nitrogen,  $N_2$ ?
- (1) 8 (3) 3  
(2) 2 (4) 6
- 13 Given the equation representing a reaction:
- $$H + H \rightarrow H_2$$
- What occurs during this reaction?
- (1) A bond is broken and energy is absorbed.  
(2) A bond is broken and energy is released.  
(3) A bond is formed and energy is absorbed.  
(4) A bond is formed and energy is released.
- 14 An atom of which element has the strongest attraction for electrons in a chemical bond?
- (1) chlorine (3) phosphorus  
(2) carbon (4) sulfur
- 15 At STP, a 50.-gram sample of  $H_2O(\ell)$  and a 100.-gram sample of  $H_2O(\ell)$  have
- (1) the same chemical properties  
(2) the same volume  
(3) different temperatures  
(4) different empirical formulas
- 16 Which statement describes a mixture of sand and water at room temperature?
- (1) It is heterogeneous, and its components are in the same phase.  
(2) It is heterogeneous, and its components are in different phases.  
(3) It is homogeneous, and its components are in the same phase.  
(4) It is homogeneous, and its components are in different phases.
- 17 Distillation is a process used to separate a mixture of liquids based on different
- (1) boiling points (3) freezing points  
(2) densities (4) solubilities
- 18 According to the kinetic molecular theory, which statement describes the particles in a sample of an ideal gas?
- (1) The particles are constantly moving in circular paths.  
(2) The particles collide, decreasing the total energy of the system.  
(3) The particles have attractive forces between them.  
(4) The particles are considered to have negligible volume.
- 19 Which sample of matter has the greatest distance between molecules at STP?
- (1)  $N_2(g)$  (3)  $C_6H_{14}(\ell)$   
(2)  $NH_3(aq)$  (4)  $C_6H_{12}O_6(s)$
- 20 For a chemical system at equilibrium, the concentrations of both the reactants and the products must
- (1) decrease (3) be constant  
(2) increase (4) be equal
- 21 In terms of disorder and energy, systems in nature have a tendency to undergo changes toward
- (1) less disorder and lower energy  
(2) less disorder and higher energy  
(3) greater disorder and lower energy  
(4) greater disorder and higher energy
- 22 The only two elements in alkenes and alkynes are
- (1) carbon and nitrogen  
(2) carbon and hydrogen  
(3) oxygen and nitrogen  
(4) oxygen and hydrogen
- 23 Which functional group contains a nitrogen atom and an oxygen atom?
- (1) ester (3) amide  
(2) ether (4) amine

- 24 When a sample of Mg(s) reacts completely with  $O_2(g)$ , the Mg(s) loses 5.0 moles of electrons. How many moles of electrons are gained by the  $O_2(g)$ ?
- (1) 1.0 mol                      (3) 5.0 mol  
(2) 2.5 mol                      (4) 10.0 mol
- 25 Which statement describes the reactions in an electrochemical cell?
- (1) Oxidation occurs at the anode, and reduction occurs at the cathode.  
(2) Oxidation occurs at the cathode, and reduction occurs at the anode.  
(3) Oxidation and reduction both occur at the cathode.  
(4) Oxidation and reduction both occur at the anode.
- 26 A 0.050 M aqueous solution of which compound is the best conductor of electric current?
- (1)  $C_3H_7OH$                       (3)  $MgSO_4$   
(2)  $C_6H_{12}O_6$                       (4)  $K_2SO_4$
- 27 What is the color of bromocresol green indicator in a solution with a pH value of 2.0?
- (1) blue                              (3) red  
(2) green                              (4) yellow
- 28 Which formula can represent hydrogen ions in an aqueous solution?
- (1)  $OH^-(aq)$                       (3)  $H_3O^+(aq)$   
(2)  $Hg_2^{2+}(aq)$                       (4)  $NH_4^+(aq)$
- 29 In which reaction is an atom of one element converted into an atom of another element?
- (1) combustion  
(2) fermentation  
(3) oxidation-reduction  
(4) transmutation
- 30 In which type of nuclear reaction do nuclei combine to form a nucleus with a greater mass?
- (1) alpha decay                      (3) fusion  
(2) beta decay                      (4) fission
-

**Part B-1**

**Answer all questions in this part.**

*Directions (31–50):* For *each* statement or question, record on your separate answer sheet the *number* of the word or expression that, of those given, best completes the statement or answers the question. Some questions may require the use of the *2011 Edition Reference Tables for Physical Setting/Chemistry*.

31 The bright-line spectra produced by four elements are represented in the diagram below.

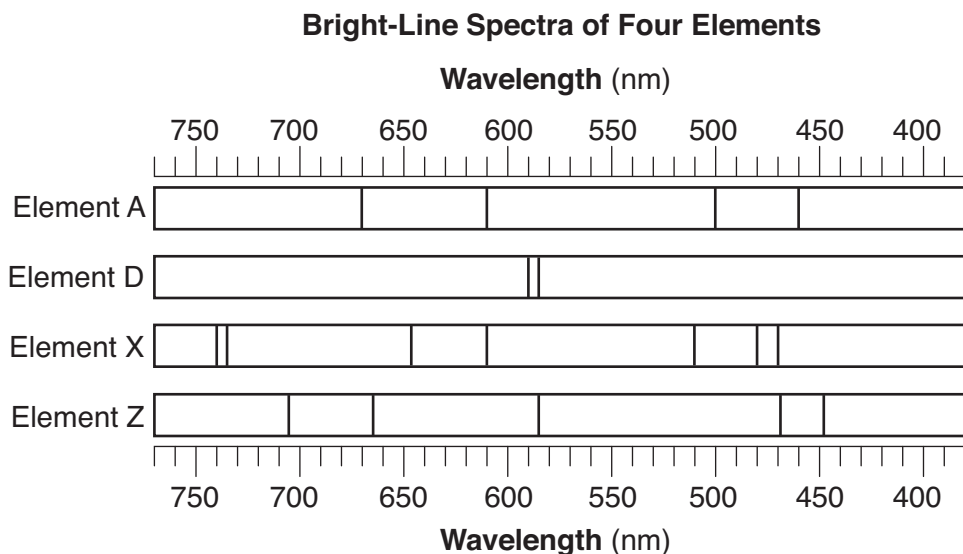

Given the bright-line spectrum of a mixture formed from two of these elements:

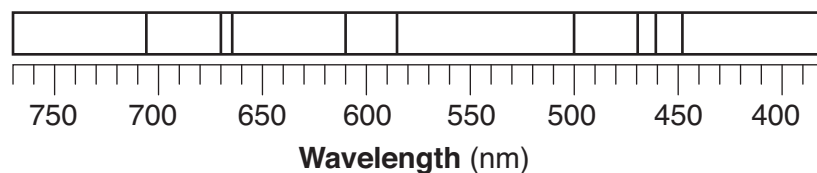

Which elements are present in this mixture?

- |             |             |
|-------------|-------------|
| (1) A and X | (3) D and X |
| (2) A and Z | (4) D and Z |
- 32 Which electron configuration represents the electrons in an atom of sulfur in an excited state?
- |               |               |
|---------------|---------------|
| (1) 2 – 8 – 6 | (3) 2 – 8 – 7 |
| (2) 2 – 7 – 7 | (4) 2 – 7 – 8 |
- 33 Which notations represent atoms that have the same number of protons but a different number of neutrons?
- |                   |                     |
|-------------------|---------------------|
| (1) H-3 and He-3  | (3) Cl-35 and Cl-37 |
| (2) S-32 and S-32 | (4) Ga-70 and Ge-73 |

34 What is the chemical name of the compound  $\text{NH}_4\text{SCN}$ ?

- (1) ammonium thiocyanate
- (2) ammonium cyanide
- (3) nitrogen hydrogen cyanide
- (4) nitrogen hydrogen sulfate

35 Which equation represents a conservation of atoms?

- (1)  $2\text{Fe} + 2\text{O}_2 \rightarrow \text{Fe}_2\text{O}_3$
- (2)  $2\text{Fe} + 3\text{O}_2 \rightarrow \text{Fe}_2\text{O}_3$
- (3)  $4\text{Fe} + 2\text{O}_2 \rightarrow 2\text{Fe}_2\text{O}_3$
- (4)  $4\text{Fe} + 3\text{O}_2 \rightarrow 2\text{Fe}_2\text{O}_3$

36 Which compound has covalent bonds?

- (1)  $\text{H}_2\text{O}$
- (2)  $\text{Li}_2\text{O}$
- (3)  $\text{Na}_2\text{O}$
- (4)  $\text{K}_2\text{O}$

37 Which particle diagram represents a sample of oxygen gas at STP?

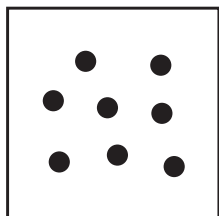
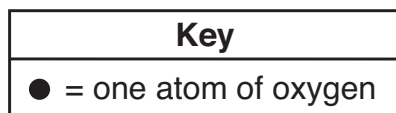

(1)

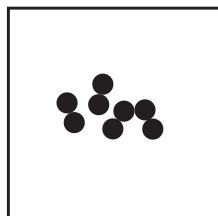

(3)

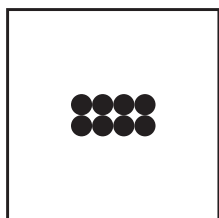

(2)

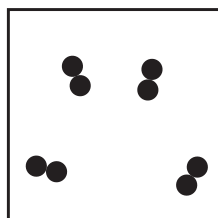

(4)

38 At which temperature and pressure will a sample of neon gas behave most like an ideal gas?

- (1) 300. K and 2.0 atm
- (2) 300. K and 4.0 atm
- (3) 500. K and 2.0 atm
- (4) 500. K and 4.0 atm

39 What is the molarity of 2.0 liters of an aqueous solution that contains 0.50 mole of potassium iodide, KI?

- (1) 1.0 M
- (2) 2.0 M
- (3) 0.25 M
- (4) 0.50 M

40 The volumes of four samples of gaseous compounds at 298 K and 101.3 kPa are shown in the table below.

Sample	Compounds	Volume (L)
1	$\text{NH}_3(\text{g})$	44.0
2	$\text{CO}_2(\text{g})$	33.0
3	$\text{HF}(\text{g})$	44.0
4	$\text{CH}_4(\text{g})$	22.0

Which two samples contain the same number of molecules?

- (1) 1 and 2
- (2) 1 and 3
- (3) 2 and 3
- (4) 2 and 4

41 Hydrochloric acid reacts faster with powdered zinc than with an equal mass of zinc strips because the greater surface area of the powdered zinc

- (1) decreases the frequency of particle collisions
- (2) decreases the activation energy of the reaction
- (3) increases the frequency of particle collisions
- (4) increases the activation energy of the reaction

42 Given the equation representing a system at equilibrium in a sealed, rigid container:

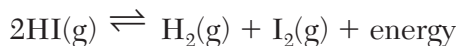

Increasing the temperature of the system causes the concentration of

- (1) HI to increase
- (2) H<sub>2</sub> to increase
- (3) HI to remain constant
- (4) H<sub>2</sub> to remain constant

43 Based on Table I, which equation represents a reaction with the greatest difference between the potential energy of the products and the potential energy of the reactants?

- (1)  $4\text{Al}(\text{s}) + 3\text{O}_2(\text{g}) \rightarrow 2\text{Al}_2\text{O}_3(\text{s})$
- (2)  $2\text{H}_2(\text{g}) + \text{O}_2(\text{g}) \rightarrow 2\text{H}_2\text{O}(\ell)$
- (3)  $\text{C}_3\text{H}_8(\text{g}) + 5\text{O}_2(\text{g}) \rightarrow 3\text{CO}_2(\text{g}) + 4\text{H}_2\text{O}(\ell)$
- (4)  $\text{C}_6\text{H}_{12}\text{O}_6(\text{s}) + 6\text{O}_2(\text{g}) \rightarrow 6\text{CO}_2(\text{g}) + 6\text{H}_2\text{O}(\ell)$

44 Which phase change results in an increase in entropy?

- (1)  $\text{I}_2(\text{g}) \rightarrow \text{I}_2(\text{s})$
- (2)  $\text{CH}_4(\text{g}) \rightarrow \text{CH}_4(\ell)$
- (3)  $\text{Br}_2(\ell) \rightarrow \text{Br}_2(\text{g})$
- (4)  $\text{H}_2\text{O}(\ell) \rightarrow \text{H}_2\text{O}(\text{s})$

45 Given the formula for a compound:

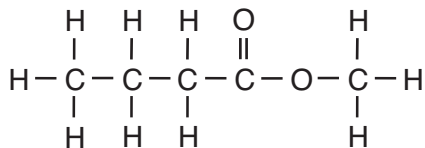

What is the name of this compound?

- (1) methyl butanoate
- (2) methyl butyl ether
- (3) pentanone
- (4) pentanoic acid

46 Given the equation representing a reaction:

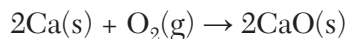

During this reaction, each element changes in

- (1) atomic number
- (2) oxidation number
- (3) number of protons per atom
- (4) number of neutrons per atom

47 Which equation represents a spontaneous reaction?

- (1)  $\text{Ca} + \text{Ba}^{2+} \rightarrow \text{Ca}^{2+} + \text{Ba}$
- (2)  $\text{Co} + \text{Zn}^{2+} \rightarrow \text{Co}^{2+} + \text{Zn}$
- (3)  $\text{Fe} + \text{Mg}^{2+} \rightarrow \text{Fe}^{2+} + \text{Mg}$
- (4)  $\text{Mn} + \text{Ni}^{2+} \rightarrow \text{Mn}^{2+} + \text{Ni}$

48 Which equation represents a neutralization reaction?

- (1)  $6\text{HClO} \rightarrow 4\text{HCl} + 2\text{HClO}_3$
- (2)  $\text{CH}_4 + 2\text{O}_2 \rightarrow \text{CO}_2 + 2\text{H}_2\text{O}$
- (3)  $\text{Ca}(\text{OH})_2 + \text{H}_2\text{SO}_4 \rightarrow \text{CaSO}_4 + 2\text{H}_2\text{O}$
- (4)  $\text{Ba}(\text{OH})_2 + \text{Cu}(\text{NO}_3)_2 \rightarrow \text{Ba}(\text{NO}_3)_2 + \text{Cu}(\text{OH})_2$

49 Which radioisotope requires long-term storage as the method of disposal, to protect living things from radiation exposure over time?

- (1) Pu-239
- (2) Fr-220
- (3) Fe-53
- (4) P-32

50 Given the equation representing a reaction:

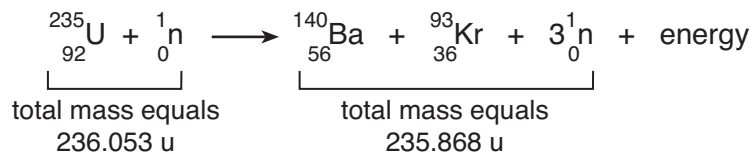

Which statement explains the energy term in this reaction?

- (1) Mass is gained due to the conversion of mass to energy.
  - (2) Mass is gained due to the conversion of energy to mass.
  - (3) Mass is lost due to the conversion of mass to energy.
  - (4) Mass is lost due to the conversion of energy to mass.
-



## Part B–2

### Answer all questions in this part.

*Directions (51-65):* Record your answers in the spaces provided in your answer booklet. Some questions may require the use of the *2011 Edition Reference Tables for Physical Setting/Chemistry*.

Base your answers to questions 51 through 53 on the information below and on your knowledge of chemistry.

The only naturally occurring isotopes of nitrogen are N-14 and N-15.

- 51 State the number of protons in an atom of N-15. [1]
- 52 State the number of electrons in each shell of a N-14 atom in the ground state. [1]
- 53 Based on the atomic mass of the element nitrogen on the Periodic Table, compare the relative abundances of the naturally occurring isotopes of nitrogen. [1]
- 

Base your answers to questions 54 through 56 on the information below and on your knowledge of chemistry.

The melting points and boiling points of five substances at standard pressure are listed on the table below.

**Melting Points and Boiling Points of Five Substances**

Substance	Melting Point (K)	Boiling Point (K)
HCl	159	188
NO	109	121
F <sub>2</sub>	53	85
Br <sub>2</sub>	266	332
I <sub>2</sub>	387	457

- 54 Identify the substance in this table that is a liquid at STP. [1]
- 55 State, in terms of the strength of intermolecular forces, why I<sub>2</sub> has a higher boiling point than F<sub>2</sub>. [1]
- 56 State what happens to the potential energy of a sample of NO(*ℓ*) at 121 K as it changes to NO(*g*) at constant temperature and standard pressure. [1]
-

Base your answers to questions 57 through 59 on the information below and on your knowledge of chemistry.

A 100.-gram sample of liquid water is heated from 20.0°C to 50.0°C. Enough  $\text{KClO}_3(\text{s})$  is dissolved in the sample of water at 50.0°C to form a saturated solution.

- 57 Using the information on Table B, determine the amount of heat absorbed by the water when the water is heated from 20.0°C to 50.0°C. [1]
- 58 Based on Table H, determine the vapor pressure of the water sample at its final temperature. [1]
- 59 Based on Table G, determine the mass of  $\text{KClO}_3(\text{s})$  that must dissolve to make a saturated solution in 100. g of  $\text{H}_2\text{O}$  at 50.0°C. [1]
- 

Base your answers to questions 60 through 62 on the information below and on your knowledge of chemistry.

The diagram and ionic equation below represent an operating voltaic cell.

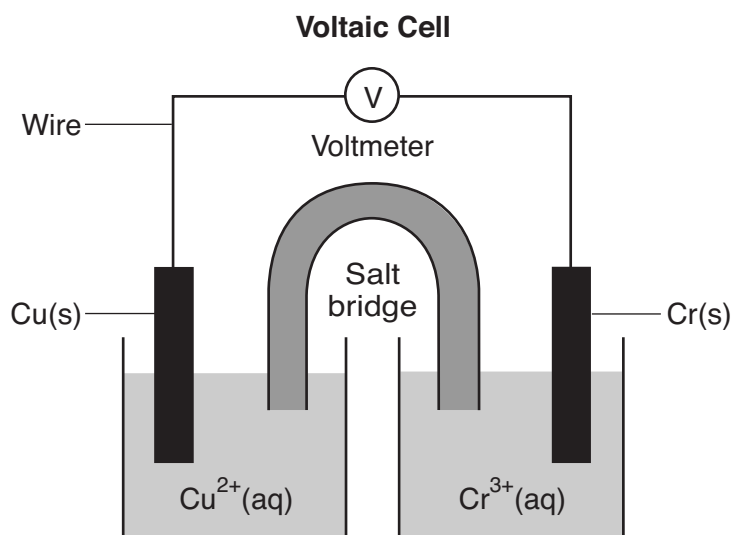

- 60 Identify the subatomic particles that flow through the wires as the cell operates. [1]
- 61 State the purpose of the salt bridge in completing the circuit in this cell. [1]
- 62 Write a balanced equation for the half-reaction that occurs in the copper half-cell when the cell operates. [1]
-

Base your answers to questions 63 through 65 on the information below and on your knowledge of chemistry.

A NaOH(aq) solution with a pH value of 13 is used to determine the molarity of a HCl(aq) solution. A 10.0-mL sample of the HCl(aq) is exactly neutralized by 16.0 mL of 0.100 M NaOH(aq). During this laboratory activity, appropriate safety equipment was used and safety procedures were followed.

- 63 Determine the molarity of the HCl(aq) sample, using the titration data. [1]
- 64 Compare the hydronium ion concentration to the hydroxide ion concentration when the HCl(aq) solution is exactly neutralized by the NaOH(aq) solution. [1]
- 65 Determine the pH value of a solution that has a  $\text{H}^+(\text{aq})$  ion concentration 10 times greater than the original NaOH(aq) solution. [1]
-

## Part C

### Answer all questions in this part.

*Directions (66-85):* Record your answers in the spaces provided in your answer booklet. Some questions may require the use of the *2011 Edition Reference Tables for Physical Setting/Chemistry*.

Base your answers to questions 66 through 68 on the information below and on your knowledge of chemistry.

A hydrate is a compound that has water molecules within its crystal structure. Magnesium sulfate heptahydrate,  $\text{MgSO}_4 \cdot 7\text{H}_2\text{O}$ , is a hydrated form of magnesium sulfate. The hydrated compound has 7 moles of  $\text{H}_2\text{O}$  for each mole of  $\text{MgSO}_4$ . When 5.06 grams of  $\text{MgSO}_4 \cdot 7\text{H}_2\text{O}$  are heated to at least  $300.^\circ\text{C}$  in a crucible by using a laboratory burner, the water molecules are released. The sample was heated repeatedly, until the remaining  $\text{MgSO}_4$  had a constant mass of 2.47 grams. During this laboratory activity, appropriate safety equipment was used and safety procedures were followed.

66 Explain why the sample in the crucible was heated repeatedly until the sample had a constant mass. [1]

67 Using the lab data, show a numerical setup for calculating the percent composition by mass of water in the hydrated compound. [1]

68 Determine the gram-formula mass of the magnesium sulfate heptahydrate. [1]

---

Base your answers to questions 69 through 71 on the information below and on your knowledge of chemistry.

Solid sodium chloride, also known as table salt, can be obtained by the solar evaporation of seawater and from underground mining. Liquid sodium chloride can be decomposed by electrolysis to produce liquid sodium and chlorine gas, as represented by the equation below.



69 State, in terms of electrons, why the radius of a  $\text{Na}^+$  ion in the table salt is smaller than the radius of a Na atom. [1]

70 Identify the noble gas that has atoms with the same number of electrons as a chloride ion in table salt. [1]

71 In the space *in your answer booklet*, draw a Lewis electron-dot diagram of a  $\text{Cl}_2$  molecule. [1]

---

Base your answers to questions 72 through 75 on the information below and on your knowledge of chemistry.

The enclosed cabin of a submarine has a volume of  $2.4 \times 10^5$  liters, a temperature of 312 K, and a pressure of 116 kPa. As people in the cabin breathe, carbon dioxide gas,  $\text{CO}_2(\text{g})$ , can build up to unsafe levels. Air in the cabin becomes unsafe to breathe when the mass of  $\text{CO}_2(\text{g})$  in this cabin exceeds 2156 grams.

- 72 State what happens to the average kinetic energy of the gas molecules if the cabin temperature *decreases*. [1]
- 73 Show a numerical setup for calculating the pressure in the submarine cabin if the cabin temperature changes to 293 K. [1]
- 74 Determine the number of moles of  $\text{CO}_2(\text{g})$  in the submarine cabin at which the air becomes unsafe to breathe. The gram-formula mass of  $\text{CO}_2$  is 44.0 g/mol. [1]
- 75 Convert the original air pressure in the cabin of the submarine to atmospheres. [1]
- 

Base your answers to questions 76 through 78 on the information below and on your knowledge of chemistry.

Automobile catalytic converters use a platinum catalyst to reduce air pollution by changing emissions such as carbon monoxide,  $\text{CO}(\text{g})$ , into carbon dioxide,  $\text{CO}_2(\text{g})$ . The uncatalyzed reaction is represented by the balanced equation below.

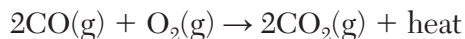

- 76 On the labeled axes *in your answer booklet*, draw a potential energy diagram for the reaction represented by this equation. [1]
- 77 Compare the activation energy of the catalyzed reaction to the activation energy of the uncatalyzed reaction. [1]
- 78 Determine the number of moles of  $\text{O}_2(\text{g})$  required to completely react with 28 moles of  $\text{CO}(\text{g})$  during this reaction. [1]
-

Base your answers to questions 79 through 81 on the information below and on your knowledge of chemistry.

The solvent 2-chloropropane can be made when chemists react propene with hydrogen chloride, as shown in the equation below.

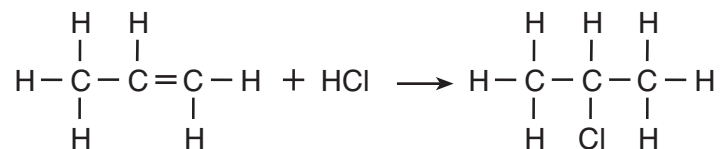

- 79 Identify the element in propene that is in all organic compounds. [1]
- 80 Explain, in terms of chemical bonds, why the hydrocarbon reactant is classified as unsaturated. [1]
- 81 Write the general formula for the homologous series to which propene belongs. [1]
-

Base your answers to questions 82 through 85 on the information below and on your knowledge of chemistry.

Radioactive emissions can be detected by a Geiger counter. When radioactive emissions enter the Geiger counter probe, which contains a noble gas such as argon or helium, some of the atoms are ionized. The ionized gas allows for a brief electric current. The current causes the speaker to make a clicking sound. To make sure that the Geiger counter is measuring radiation properly, the device is tested using the radioisotope Cs-137.

To detect gamma radiation, an aluminum shield can be placed over the probe window, to keep alpha and beta radiation from entering the probe. A diagram that represents the Geiger counter is shown below.

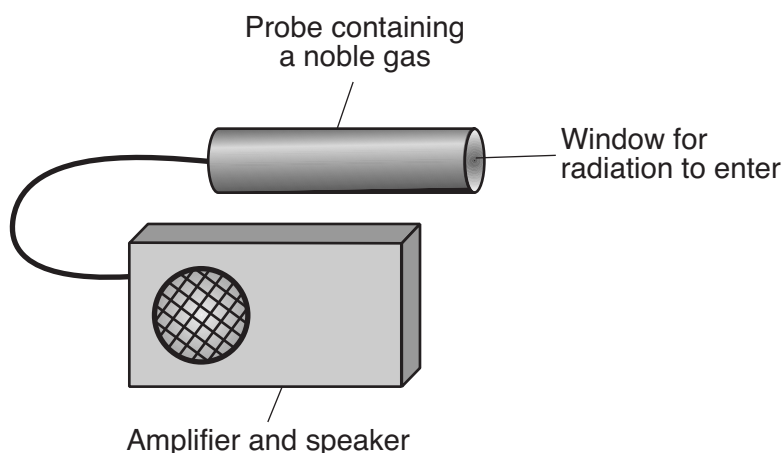

82 Compare the first ionization energy of argon to the first ionization energy of helium. [1]

83 State evidence from the passage that gamma radiation has greater penetrating power than alpha or beta radiation. [1]

84 Determine the time required for a sample of cesium-137 to decay until only  $\frac{1}{8}$  of the original sample remains unchanged. [1]

85 Complete the nuclear equation *in your answer booklet* for the decay of Cs-137 by writing a notation for the missing product. [1]

---

P.S./CHEMISTRY

Printed on Recycled Paper

P.S./CHEMISTRY