



New York State Testing Program

Mathematics Book 1

Grade

3

Sample Test 2005

TIPS FOR TAKING THE SAMPLE TEST

Here are some suggestions to help you do your best:

- Be sure to read carefully all the directions in the test book.
- You may use your tools to help you solve any problem on the test.
- Read each question carefully and think about the answer before choosing your response.



This picture means that you will use your ruler.



This picture means that you will use your pattern blocks.



This picture means that you will use your counters.

Sample A

$$\begin{array}{r} 227 \\ + 14 \\ \hline \end{array}$$

- A 311
- B 241
- C 231
- D 232

Sample B

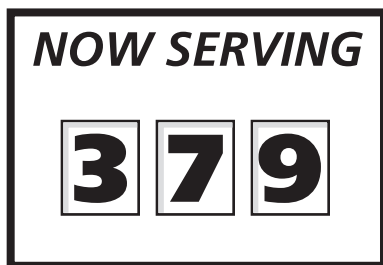

What number will be served next?



F



G



H



J

Sample C



Use your ruler to help you solve this problem.

How many inches long is the toothbrush shown below?

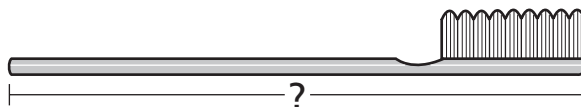

- A 2
- B $2\frac{1}{2}$
- C 3
- D $3\frac{1}{2}$

STOP

1 Which number is the same as two hundred seven?

- A 27
- B 207
- C 270
- D 277

2 Which boat has an odd number on it?

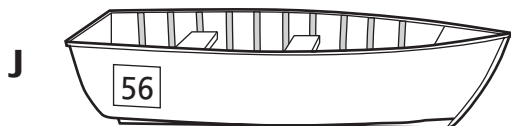
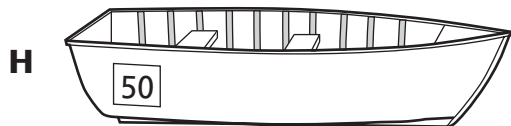
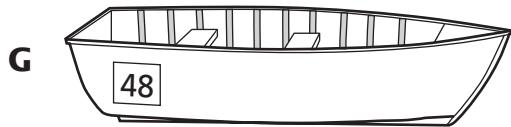
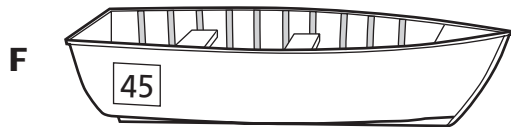

Go On

3

Dolores bought an apple for \$0.52. Which set of coins shows \$0.52?

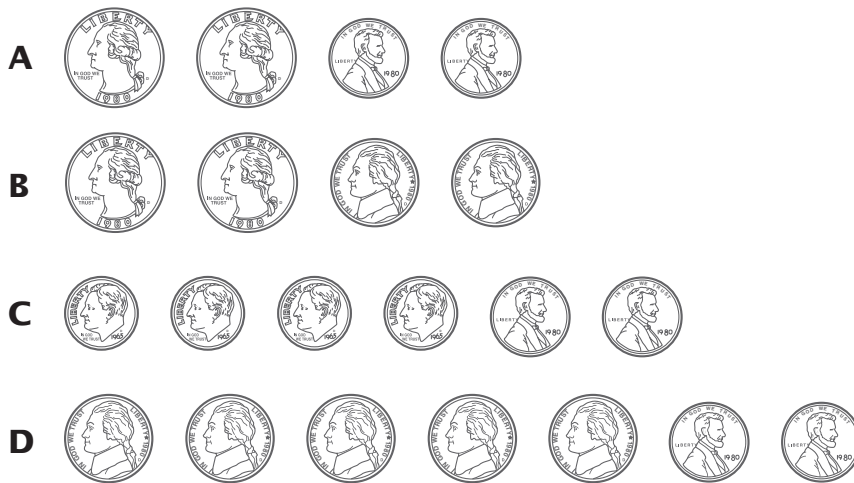
**4**

There are 143 trees in a park. What is 143 rounded to the nearest 10?

F 100

G 140

H 145

J 150

- 5** Lee wrote the number sentence below.

$$26 + 14 = \square + 26$$

What number belongs in the box to make the number sentence correct?

- A** 66
- B** 40
- C** 26
- D** 14

- 6** Use your ruler to help you solve this problem.



Ms. Sanchez has the three keys shown below.

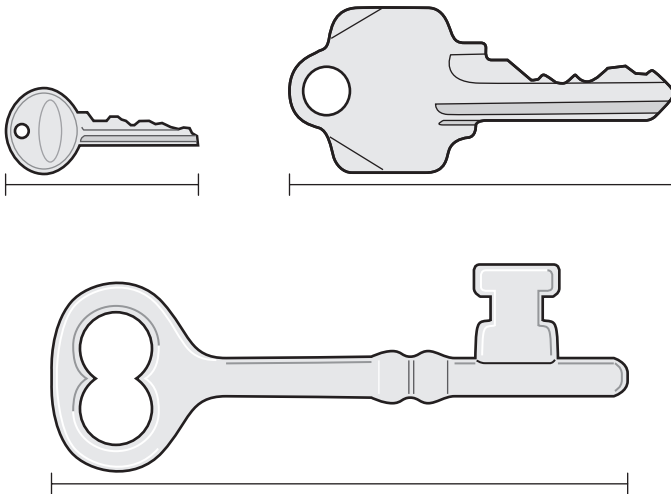

How many inches long is the **longest** key?

- F** 1
- G** 2
- H** 3
- J** 4

7

A number is missing from the pattern below.

25, 50, 75, 100, _____, 150, 175

What is the missing number from the pattern?

- A** 101
- B** 105
- C** 125
- D** 140

8

Use your ruler to help you solve this problem.

How many inches long is the picture of the comb shown below?

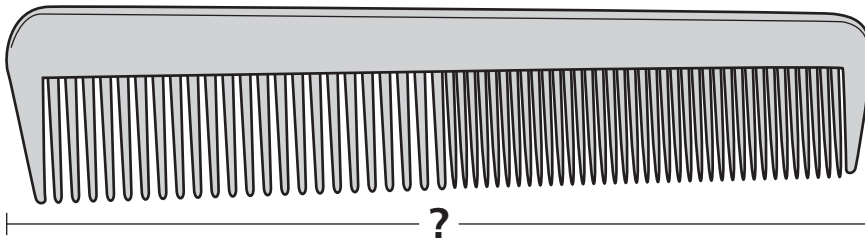

- F** 4
- G** $4\frac{1}{2}$
- H** 5
- J** $5\frac{1}{2}$

9 Which shape is a hexagon?

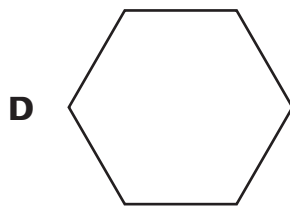
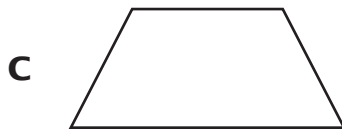
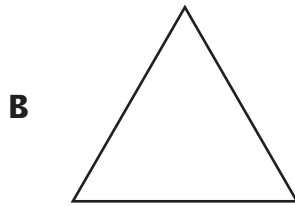

10 Sarah writes the number pattern below.

15, 20, 25, 30, 35, _____

How would Sarah find the next number in the pattern?

- F** add 5 to 35
- G** subtract 5 from 35
- H** multiply 35 by 5
- J** divide 35 by 5

Go On

11

Dan bought the two boxes of paper clips shown below.

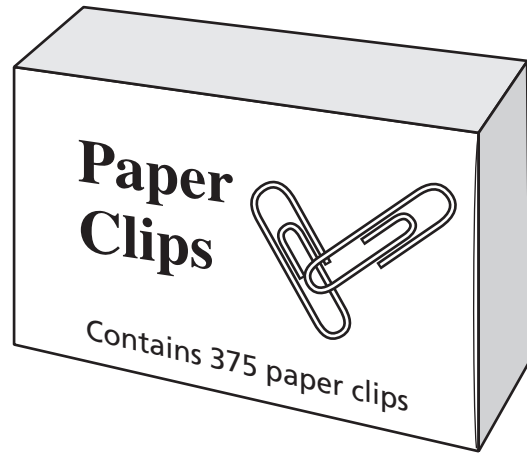
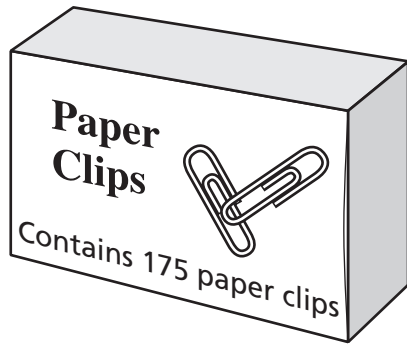

What is the total number of paper clips in the two boxes?

- A 440
- B 450
- C 540
- D 550

12

Students in Sophie's class made 721 paper flowers. They gave 413 paper flowers to another class. How many paper flowers did Sophie's class have left?

- F 208
- G 308
- H 312
- J 318

13

Ali wants to give 27 baseball cards to 3 of his friends. He gives the same number of baseball cards to each friend. How many baseball cards does Ali give to each friend?

- A 3
- B 7
- C 8
- D 9

14

Beth bought two of the stickers shown below. She spent **about** 60¢ in all.



13¢



21¢



38¢



29¢

What are the prices of the two stickers Beth bought?

- F 13¢ and 38¢
- G 21¢ and 29¢
- H 21¢ and 38¢
- J 29¢ and 38¢

Go On

- 15** Anna drew the butterflies shown below.

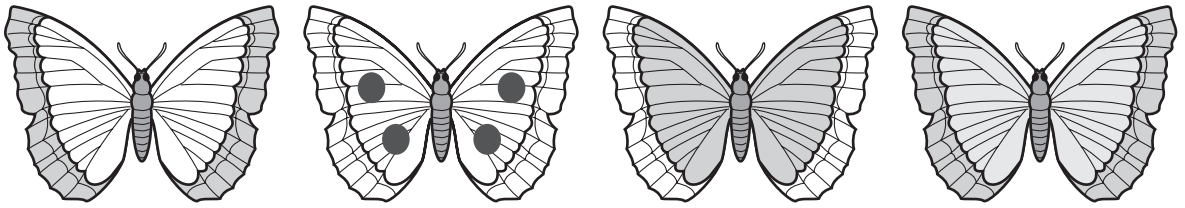

What fraction of the set of butterflies has dots?

- A $\frac{1}{2}$
- B $\frac{1}{3}$
- C $\frac{1}{4}$
- D $\frac{1}{5}$

- 16** Val writes the number sentence below.

$$438 > \square$$

Which number belongs in the box to make the number sentence correct?

- F 428
- G 438
- H 439
- J 449

17 By how much would the value of 23 change if the digit 2 were replaced by the digit 6?

- A 4
- B 6
- C 40
- D 60

18 Taylor keeps his sports cards in the box shown below.

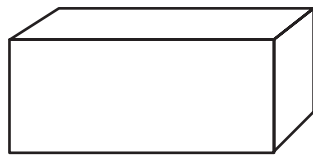

Which figure could be the shape of one face of Taylor's box?

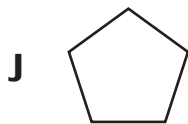
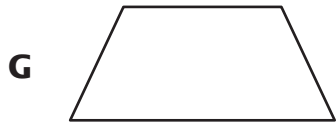
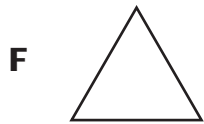

19

On Saturday, it started snowing at 12:30. Which clock shows the time it started snowing?

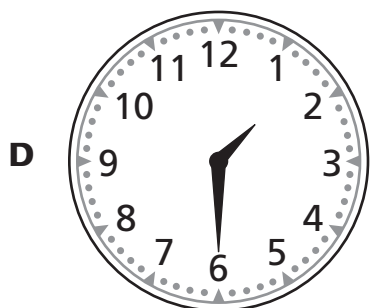
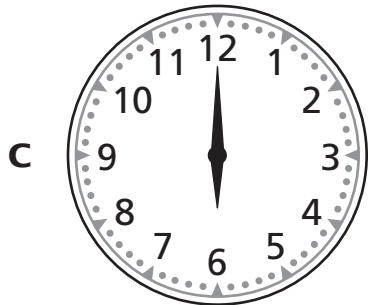
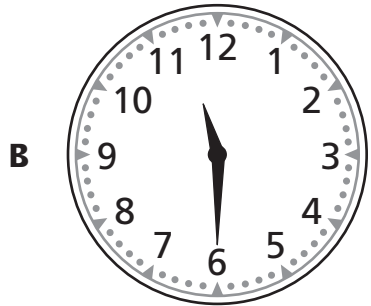
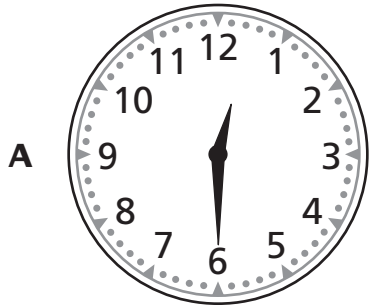

20 Which number is the same as 1 thousand?

- F** 1 hundred
- G** 10 ones
- H** 10 hundreds
- J** 100 ones

21 Mandy has 4 rows of tomato plants in her garden. There are 8 plants in each row. What is the total number of tomato plants in Mandy's garden?

- A** 12
- B** 28
- C** 32
- D** 36

Go On

- 22** Darnell painted $\frac{1}{4}$ of his door gray. Which picture could be Darnell's door?

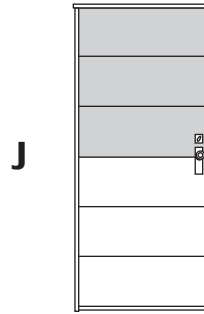
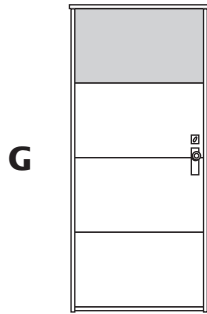
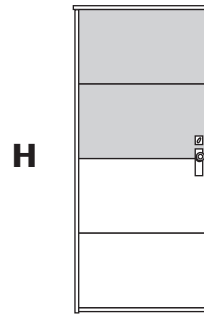
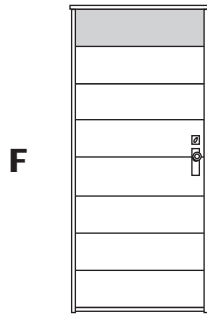

- 23** Which unit of measure is **best** for measuring the length of a toothbrush?

- A** foot
- B** yard
- C** inch
- D** pound

24 What is the shape of the basketball shown below?

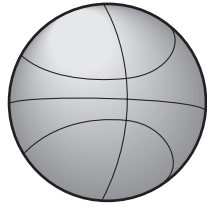

- F cone
- G cube
- H prism
- J sphere

25 Rachel and her friends swam laps in a pool. The bar graph below shows the number of laps each friend swam.

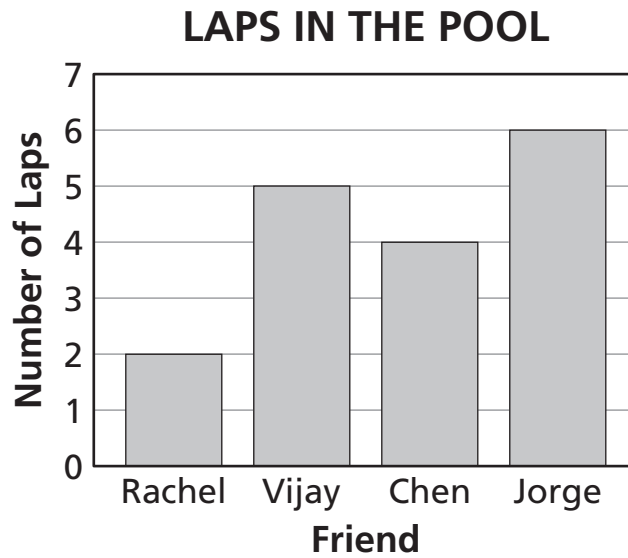

How many **more** laps did Jorge swim than Rachel?

- A 2
- B 4
- C 6
- D 8

STOP



Grade 3
Mathematics
Book 1
Sample Test 2005

The McGraw-Hill Companies