



New York State Testing Program

Mathematics

Book 2 

May 6–8, 2003

Name _____



Developed and published by CTB/McGraw-Hill LLC, a subsidiary of The McGraw-Hill Companies, Inc., 20 Ryan Ranch Road, Monterey, California 93940-5703. Copyright © 2003 by New York State Education Department. All rights reserved. No part of this publication may be reproduced or distributed in any form or by any means, or stored in a database or retrieval system, without the prior written permission of New York State Education Department.

TIPS FOR TAKING THE TEST

Here are some suggestions to help you do your best:

- Be sure to carefully read all the directions in the Test Book.
- Ask your teacher to explain any directions you do not understand.
- You may use your tools to help you solve any problem on the test.
- Read each question carefully and think about the answer before writing a response.
- Be sure to show your work when asked. You may receive partial credit if you have shown your work.



This picture means that you will use your ruler.



This picture means that you will use your pattern blocks.



This picture means that you will use your counters.

- 31** There are 157 students in the fourth grade. On the day of a test, 9 students were absent. Each student taking the test was given 2 pencils. What was the total number of pencils given to the students who took the test that day?

Show your work.

Answer _____ pencils

32

Part A

In the diagrams below, shade in the correct number of boxes that will show each decimal number.

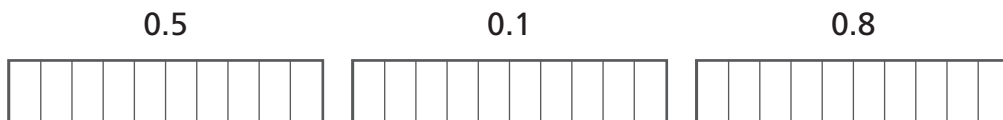

Part B

On the lines below, write the 3 decimal numbers from Part A in order from *least to greatest*.

Go On



Use your ruler to help you solve this problem.

Part A

Mr. Ortiz is using the wrench below to repair a car. How many centimeters wide is the opening of the wrench?

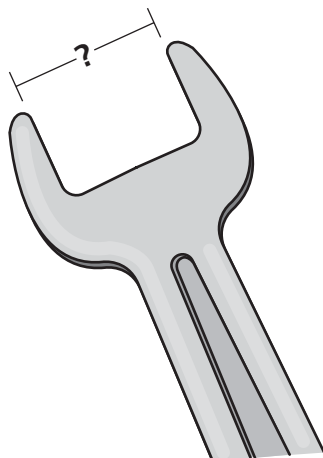

Answer _____ centimeters

Part B

Mr. Ortiz has a bolt that is 11 millimeters wide. Draw a circle around the bolt that measures exactly 11 millimeters wide.

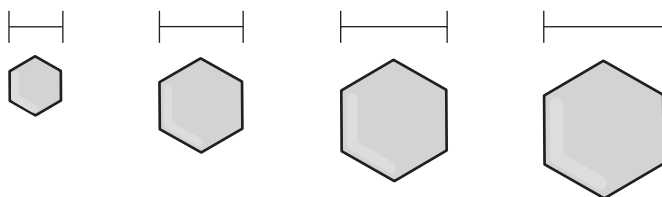

34

Abe, Brian, Chuck, and Dean are standing in line.

- Abe and Chuck are next to each other.
- Brian is last in line.
- Dean is not next to either Brian or Chuck.

Write a name on the line under each of the boys below to show in what order Abe, Brian, Chuck, and Dean are standing.

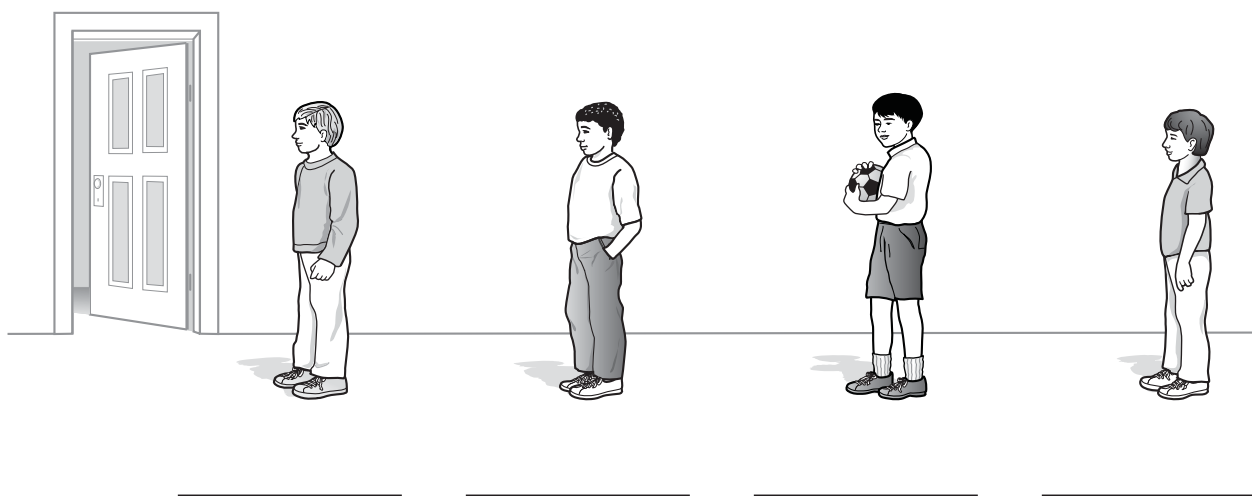

Go On

Kevin and his father made a model house out of wood. The roof was made in two pieces with the dimensions shown below.

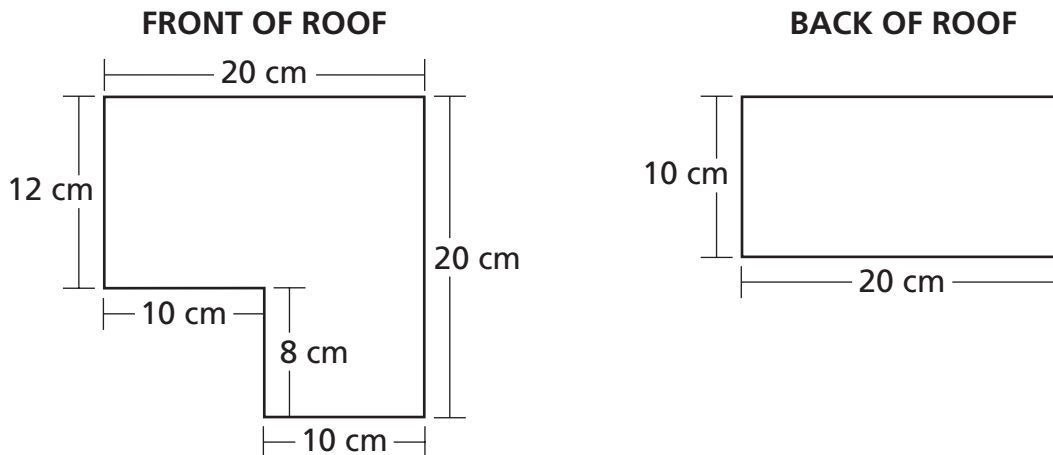

Part A

What is the perimeter, in centimeters, of the **front** of the roof?

Answer _____ centimeters

Part B

What is the area, in square centimeters, of the **back** of the roof?

$\text{Area} = \text{length} \times \text{width}$

Answer _____ square centimeters

Part A

Harriet has 3 more posters than Brooke. Brooke has 4 posters.

On the line below, write a number sentence that shows the number of posters Harriet has.

Answer _____

Part B

Donald has 3 more posters than Lyn. Donald has 6 posters.

On the line below, write a number sentence that shows the number of posters Lyn has.

Answer _____

Go On

37 Warren asked the students in his class what they ate for breakfast. The tally chart below shows what the students ate.

WARREN'S BREAKFAST SURVEY

Breakfast	Number of Students
Pancakes	///
Cereal	### ### /
Eggs	### //
Doughnuts	////

Using the information from the tally chart, make a bar graph on the grid below to show how many students ate each type of breakfast.

Be sure to

- title the graph
- label the axes
- graph all the data
- use an appropriate scale

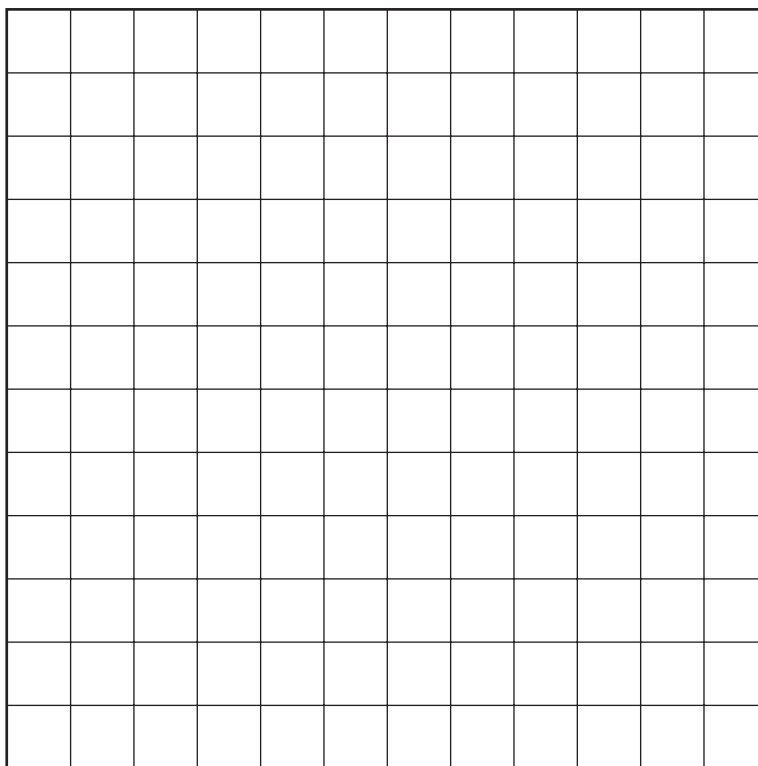

38

Heather used straws of equal length and pieces of clay to make a model shaped like a cube. A diagram of her unfinished model is shown below.

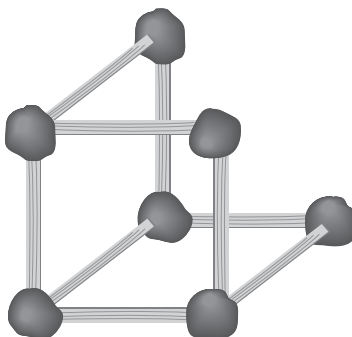

Part A

Draw the remaining edges and vertex in the diagram to complete her model.

Part B

How many straws, in all, will she use to make the finished model?

Answer _____ straws

39



Use your counters to help you solve this problem.

Kyle, Lee, and Melissa collected 14 rocks for science class. Lee has 5 rocks. Kyle has fewer rocks than Lee. Melissa has twice as many rocks as Kyle.

Part A

In the table below, write the number of rocks that Kyle and Melissa have.

ROCKS COLLECTED

Name	Rocks
Kyle	
Lee	5
Melissa	
Total	14

Part B

On the lines below, explain how you found your answer. Use words, symbols, or both in your explanation.

STOP

Do NOT turn this page until you are told to do so.

Session 3

40

Mr. Valdez bought 30 newspapers in a month. Below are the newspapers that he saved from that month.

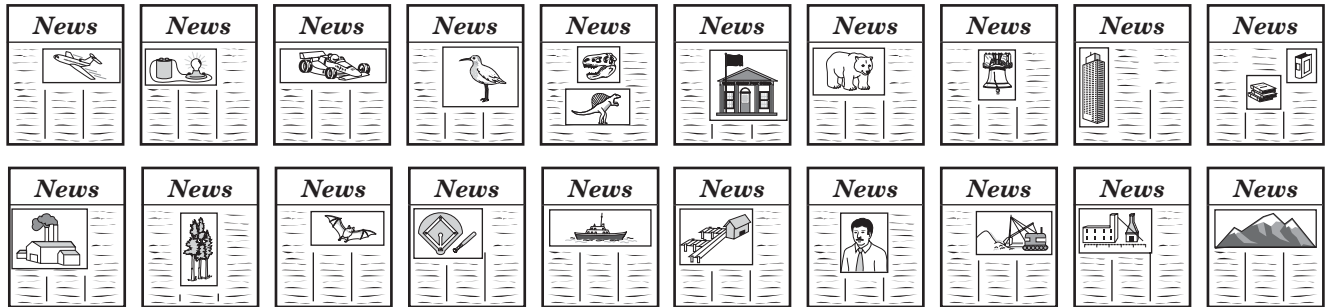

Part A

How many newspapers are missing from the 30 newspapers Mr. Valdez bought?

Show your work.

Answer _____ newspapers

Part B

What fraction of the 30 newspapers Mr. Valdez bought are missing?

Answer _____

- 41** There are 112 doughnuts in the display case at Dorothy’s Bakery. The bakery sells jelly, chocolate, and glazed doughnuts. If there are 24 jelly doughnuts and 33 chocolate doughnuts in the display case, how many **glazed** doughnuts are in the display case?

Show your work.

Answer _____ glazed doughnuts

- 42** Makoto has a collection of 100 trading cards. He gives 15 cards to his best friend. Makoto then gives 10 of the cards he has left to his brother. What percent of Makoto’s collection of trading cards did he give away?

Answer _____%

What percent of his collection does he still have left?

Answer _____%

43



Use your ruler to help you solve this problem.

Part A

In the space below, draw a rectangle that is 10 centimeters long and 5 centimeters wide.

Part B

Draw in the missing sides to complete the square and the triangle.



Square



Triangle

44

Mary Ann wants to buy a pair of skates for \$55. She has \$20 saved in the bank. If she saves \$5 every week, how many weeks will it take Mary Ann to save enough money to buy the skates?

Show your work.

Answer _____ weeks

Go On

45

Colin put some buttons on a table. There were 4 blue buttons, 5 red buttons, 7 tan buttons, and 8 white buttons.

Colin's cat jumped up and knocked 1 button onto the floor. What is the probability that the button on the floor was blue?

Show your work.

Answer _____

46

Paula went shopping and spent a total of \$92.00. She bought 1 pair of sunglasses, 2 hats, and 4 shirts.

Complete the table below by filling in the Total Cost for each type of item and the price of the sunglasses. The sum of the Total Costs for the 3 types of items should add up to \$92.00.

PAULA'S SHOPPING TRIP

Type of Item	Number Bought	Price	Total Cost
Sunglasses	1		
Hat	2	\$12.00 each	
Shirt	4	\$15.00 each	
TOTAL SPENT			\$92.00

47

Mark made a pattern by drawing 7 rows of stars. He added more stars to each row, as shown in the table below.

MARK'S PATTERN

Row	1	2	3	4	5	6	7
Number of Stars	1	3	6	10	15		

Part A

How many stars will he draw in Row 7 ?

Answer _____ stars

Part B

If the pattern continues, which row will have 45 stars in it?

Row _____

Part C

On the lines below, describe Mark's pattern of rows of stars.

Alan made a banner by taping the long edges of 10 pieces of paper together as shown below.

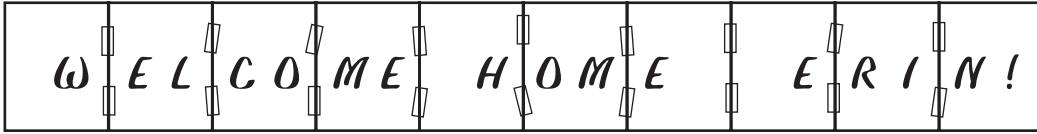

Each piece of paper is 22 centimeters wide and 28 centimeters long.

Part A

What is the perimeter of 1 piece of paper?

Show your work.

Answer _____ centimeters

Part B

What is the perimeter of the banner?

Show your work.

Answer _____ centimeters

STOP

Place Student Label Here



Book 2
Mathematics
Grade 4
May 6–8, 2003

The McGraw-Hill Companies
