

THE UNIVERSITY OF THE STATE OF NEW YORK

GRADE 4 Large Type Edition

ELEMENTARY-LEVEL SCIENCE TEST

WRITTEN TEST

v202

Student Name _____

School Name _____

The possession or use of any communications device is strictly prohibited when taking this examination. If you have or use any communications device, no matter how briefly, your examination will be invalidated and no score will be calculated for you.

Print your name and the name of your school on the lines above.

The test has two parts. Parts I and II are in this test booklet.

Part I contains 30 multiple-choice questions. Record your answers to these questions on the separate answer sheet. Use only a No. 2 pencil on your answer sheet.

Part II consists of 15 open-ended questions. Write your answers to Part II in this test booklet.

You will have as much time as you need to answer the questions.

DO NOT TURN THIS PAGE UNTIL YOU ARE TOLD TO DO SO.

Copyright 2021
THE UNIVERSITY OF THE STATE OF NEW YORK
THE STATE EDUCATION DEPARTMENT
ALBANY, NEW YORK 12234

NO PART OF THIS TEST MAY BE REPRODUCED AND/OR TRANSMITTED BY ANY MEANS WITHOUT WRITTEN PERMISSION.

DIRECTIONS

There are 30 questions on Part I of this test. Each question is followed by four choices, labeled A–D. Read each question carefully. Decide which choice is the best answer. On the separate answer sheet, mark your answer in the row of circles for each question by filling in the circle that has the same letter as the answer you have chosen. Use a No. 2 pencil to mark the answer sheet.

Read Sample Question **S-1** below.

S-1 Frozen water is called

- A fog
- B ice
- C steam
- D vapor

The correct answer is **ice**, which is next to letter **B**. On your answer sheet, look at the box showing the row of answer circles for Sample Question **S-1**. See how the circle for letter **B** has been filled in.

Now read Sample Question **S-2**. Mark your answer on the answer sheet in the box showing the row of answer circles for Sample Question **S-2**.

S-2 Which animal has wings?

- A bird
- B frog
- C mouse
- D rabbit





























The correct answer is **bird**, which is next to letter **A**. On your answer sheet, you should have filled in circle **A**.

Answer all 30 questions on Part I of this test. Fill in only one circle for each question. Be sure to erase completely any answer you want to change. You may not know the answers to some of the questions, but do the best you can on each one.

When you have finished Part I, go on to Part II. Answer all of the questions in Part II in the space for each question.

Part I

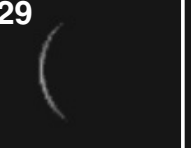
- 1 The calendar below shows photographs of the changing appearance of the Moon in the sky for one month.

March 2014						
Sunday	Monday	Tuesday	Wednesday	Thursday	Friday	Saturday
						1
2 	3 	4 	5 	6 	7 	8 
9 	10 	11 	12 	13 	14 	15 
16 	17 	18 	19 	20 	21 	22 
23 	24 	25 	26 	27 	28 	29 
30	31 					

The changing appearance of the Moon is an example of a

- A natural cycle
 - B transfer of energy
 - C weather condition
 - D mechanical force
- 2 How much time does it take Earth to travel once around the Sun?
- A one day
 - B one week
 - C one month
 - D one year

3 The Sun appears to rise and set daily due to

- A Earth's rotation
- B Earth's revolution
- C the Sun's rotation
- D the Sun's revolution

4 The photographs below show the shape of a stream before and after a heavy rainstorm.

Before a Heavy Rainstorm



After a Heavy Rainstorm

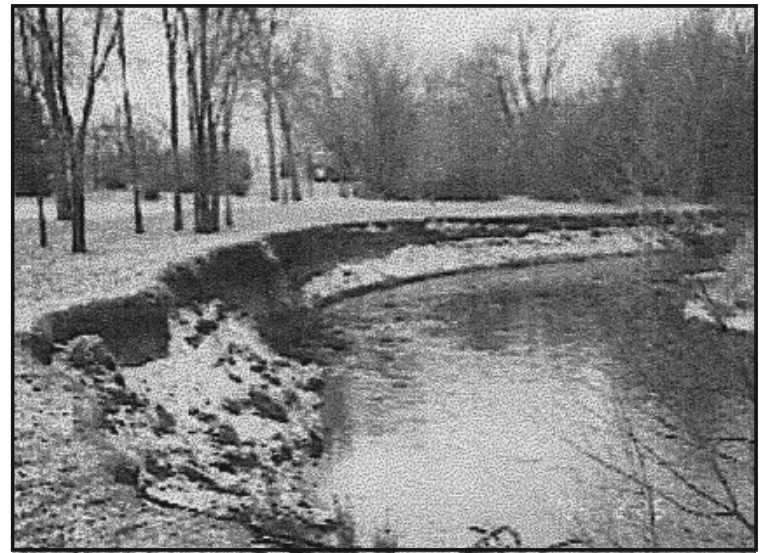

Which process most likely caused the shape of the stream to change after the rainstorm?

- A condensation
 - B revolution
 - C erosion
 - D evaporation
- 5 Which property of a rock can a student best observe by touching it with their hand?
- A color
 - B odor
 - C taste
 - D texture

6 A circuit tester is best used to determine an object's

- A reflectiveness
- B conductivity
- C flexibility
- D weight

7 The diagrams below show an umbrella on a beach at different times during the day.

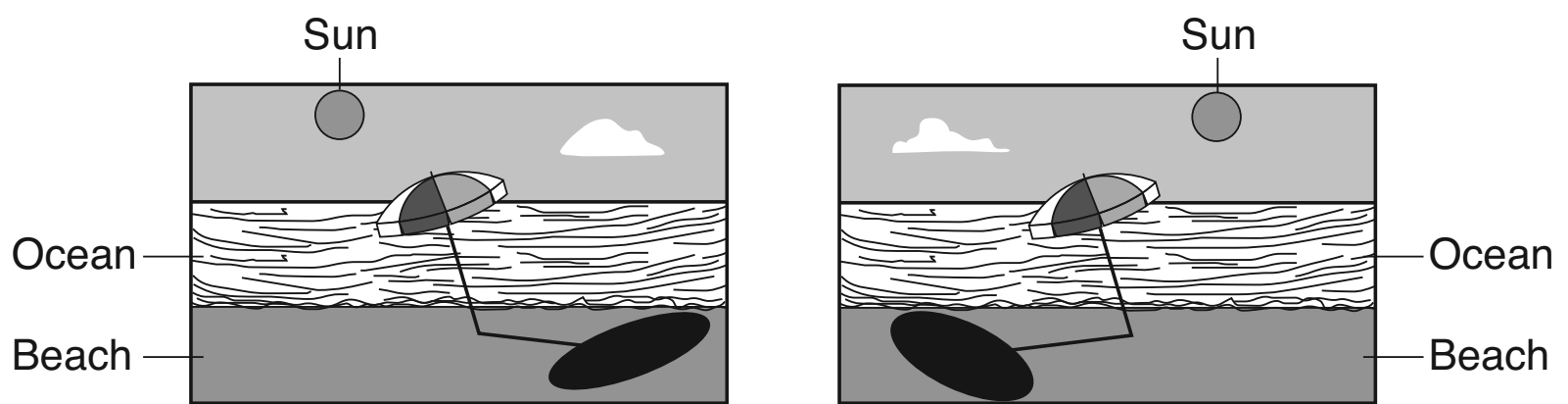

The diagrams best show how the surrounding conditions affect the umbrella's

- A shadow
- B size
- C shape
- D texture

Base your answers to questions 8 and 9 on the information and diagrams below, and on your knowledge of science.

The diagrams show three shoes on a wooden board. In diagram *A*, the board is lying flat on the ground. In diagram *B*, a rope has been used to lift one end of the board. The shoes in diagram *B* did **not** slide down the board when the board was lifted.

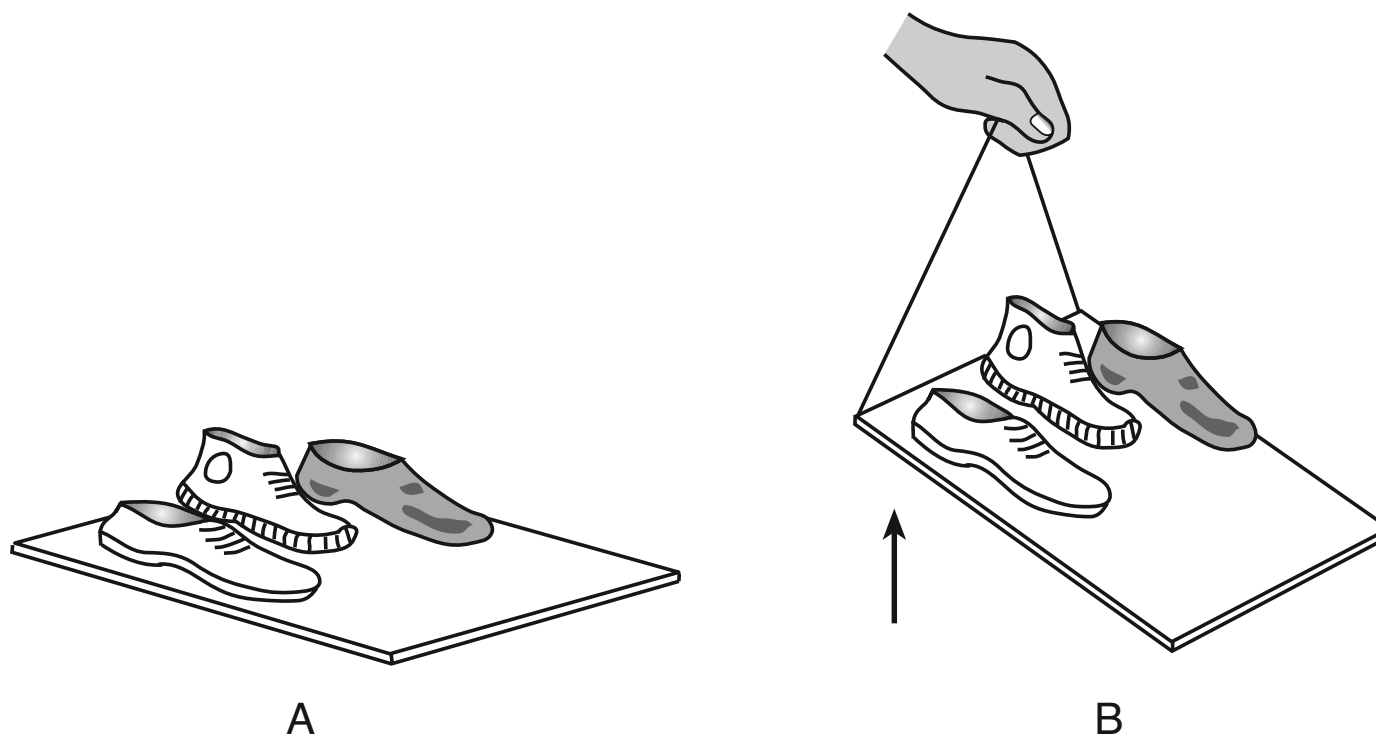

- 8 Which form of energy is used to lift the board in diagram *B*?
- A light
 - B heat
 - C mechanical
 - D sound
- 9 The force that keeps the shoes from sliding down the board in diagram *B* is
- A electricity
 - B magnetism
 - C friction
 - D gravity

10 The diagram below shows four parts of a closed circuit.

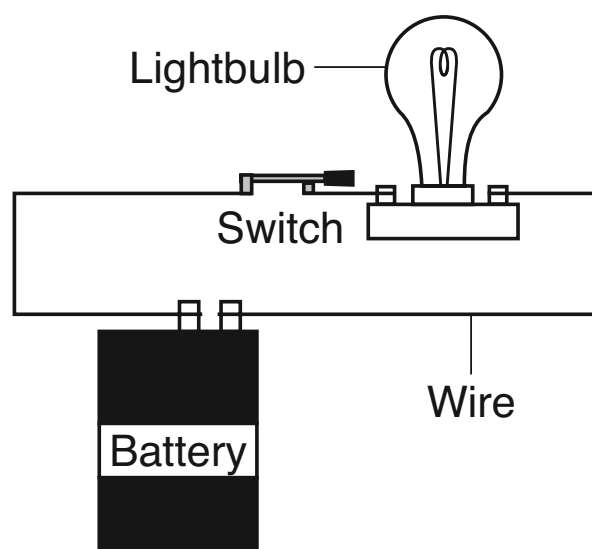

Which object is a source of electric energy in the closed circuit?

- A battery
 - B lightbulb
 - C switch
 - D wire
- 11 Which statement is an example of a *harmful* interaction with light energy from the Sun?
- A A teacher uses a calculator powered by sunlight.
 - B A student gets sunburned at the beach.
 - C A turtle warms itself on a sunny rock.
 - D Plant leaves use sunlight to make their own food.

12 The diagram below shows several different shapes.

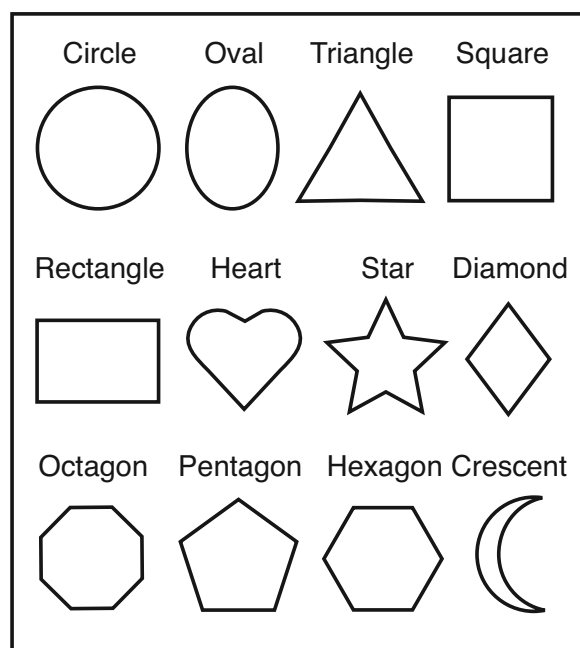

Which statement correctly identifies the shapes located directly above and directly below the heart in the diagram?

- A The circle is above and the triangle is below the heart.
- B The octagon is above and the diamond is below the heart.
- C The star is above and the rectangle is below the heart.
- D The oval is above and the pentagon is below the heart.

13 The diagram below shows a crowbar, which is being used as a simple machine to remove a nail.

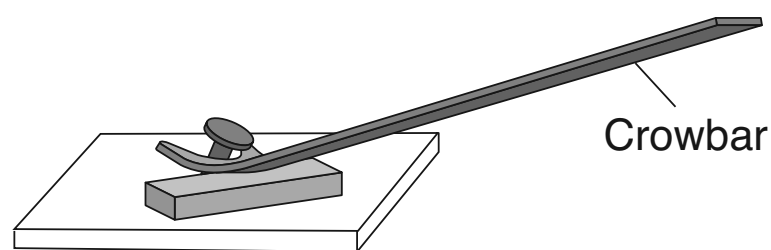

The crowbar is an example of

- A a pulley
- B a lever
- C a pan balance
- D an inclined plane

14 Two cars are parked outside on a hot, sunny day. The cars are the same size and shape. One car is black and the other is white. They have been parked in the Sun for four hours.

The roof of the black car compared to the roof of the white car is most likely

- A cooler, because it absorbs more sunlight
- B cooler, because it absorbs less sunlight
- C warmer, because it absorbs more sunlight
- D warmer, because it absorbs less sunlight

15 A student goes to school in the morning, takes a test, eats lunch, and plays drums. Which of these activities is a life process?

- A going to school
- B taking a test
- C eating lunch
- D playing drums

16 Which example of a *nonliving* thing is created by humans?

- A water
- B air
- C sunlight
- D paper

17 Which characteristic can children inherit from their parents?

- A a scar
- B eye color
- C reading a book
- D riding a bicycle

18 An apple falls off a tree and rolls into a stream. The apple floats down the stream and away from the tree. This is an example of

- A migration
- B seed dispersal
- C adapting to the environment
- D changing weather conditions

19 The diagram below shows two giraffes by a tree.

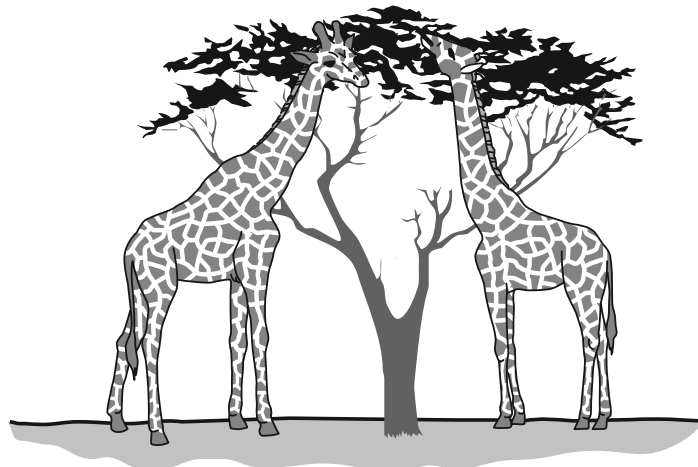

The two giraffes, trying to get leaves from the tree, are competing for

- A food
- B space
- C sunlight
- D air

20 Which **two** processes cause the height of a human to increase from birth to adulthood?

- A growth and development
- B growth and elimination
- C respiration and development
- D respiration and elimination

21 Which diagram has the stages of plant development labeled correctly?

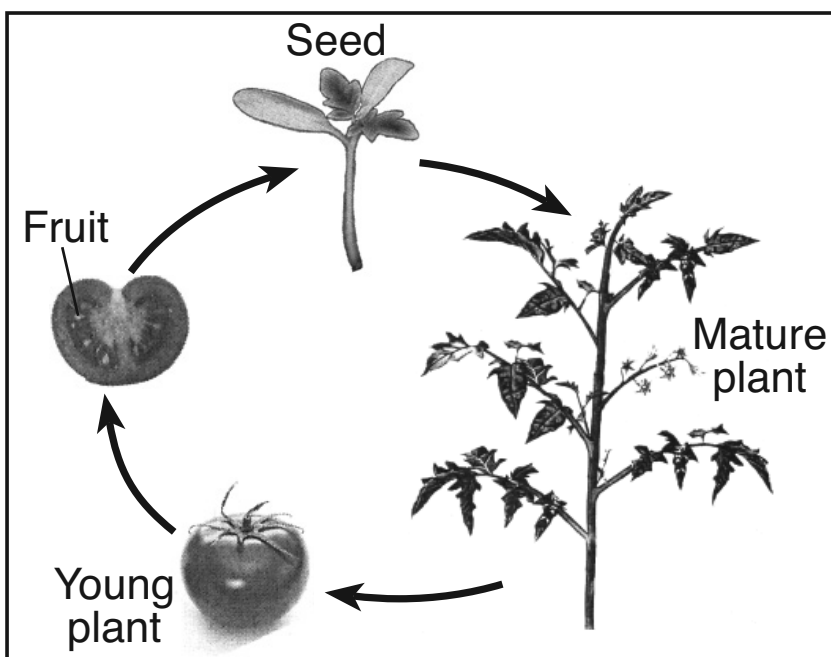

A

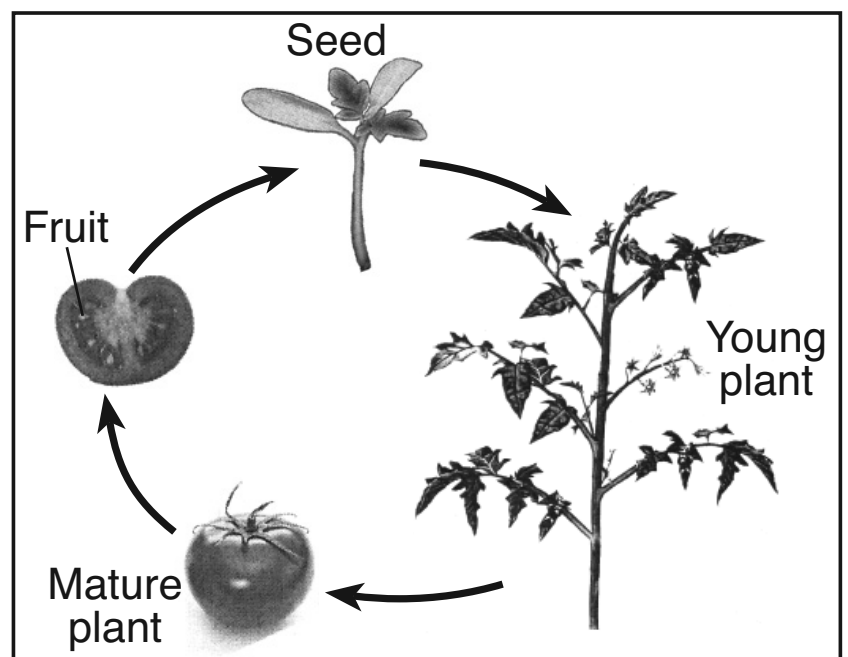

C

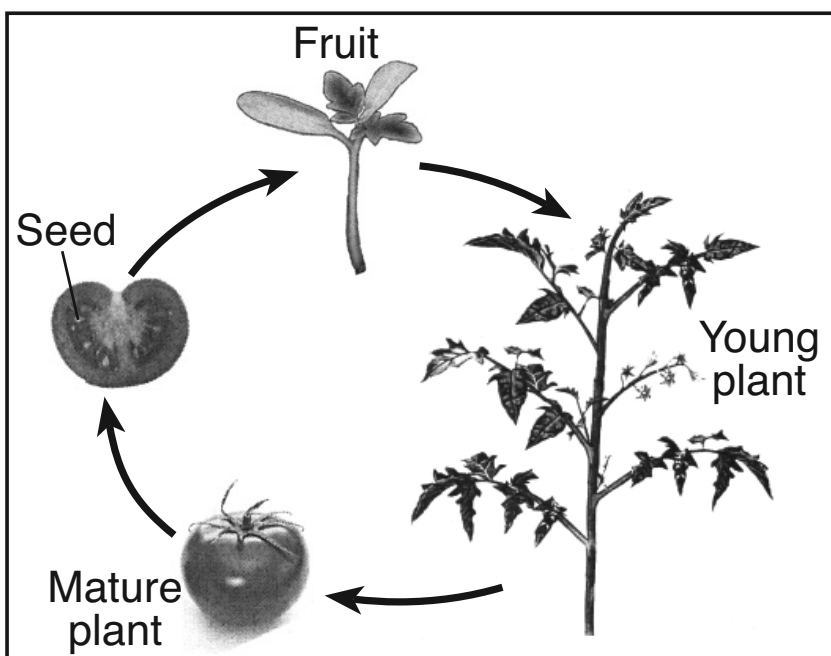

B

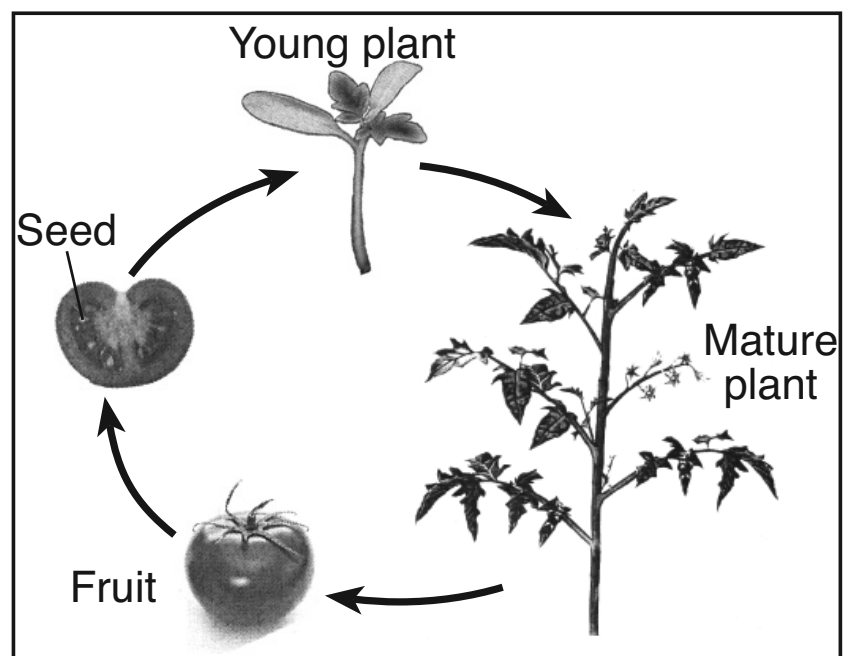

D

(Not drawn to scale)

- 22** A camel's hump stores fat to help the animal survive for up to two weeks without food while walking in the desert. This body structure has helped the camel
- A make food
 - B create a shelter
 - C adapt to its environment
 - D blend in with its environment
- 23** White-tailed deer raise their tails to signal danger to the other deer nearby. This behavior is an example of the deer
- A hibernating
 - B communicating
 - C reproducing
 - D migrating
- 24** A forest is cleared to make way for a housing development. The *loss* of which environmental condition would most likely have a *negative* effect on wildlife that were living in the forest?
- A wind
 - B shelter
 - C sunlight
 - D precipitation
- 25** For their bodies to grow and repair themselves, animals need
- A food
 - B mates
 - C shelter
 - D light

26 A decomposer is an organism that

- A recycles nutrients
- B absorbs sunlight
- C produces food
- D makes seeds

27 Students in a science class measured the length of their desks using the length of a finger. The results of their measurements are shown in the graph below. Each X represents one student.

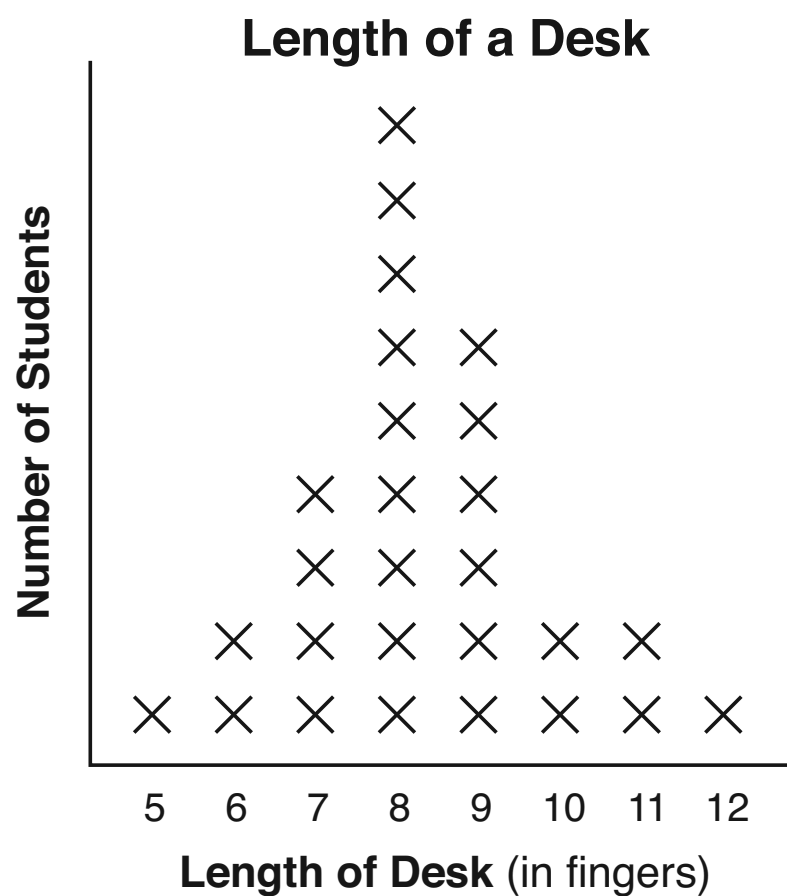

How many students measured the length of the desk as 9 fingers?

- A 2
- B 4
- C 6
- D 8

28 Two identical plants are in identical pots with the same amount of soil. Only one plant gets water every day. Both plants get the same amount of light and air. This experiment tests how plants respond to

- A air
- B light
- C soil
- D water

29 The data table below shows the distance, in centimeters (cm), a toy car traveled in 5, 10, and 15 seconds.

Data Table

Number of Seconds	Distance Traveled by Toy Car (cm)
5	120
10	240
15	360

If the pattern shown in the data table continues, how far will the car travel in 20 seconds?

- A 400 cm
- B 480 cm
- C 600 cm
- D 720 cm

30 The average monthly air temperature in Albany, New York increases each month from February to June. Which data table accurately shows these average monthly air temperatures for Albany, New York?

Month	Average Air Temperature (°F)
February	25
March	35
April	58
May	46
June	67

A

Month	Average Air Temperature (°F)
February	25
March	35
April	47
May	58
June	57

C

Month	Average Air Temperature (°F)
February	25
March	25
April	47
May	58
June	67

B

Month	Average Air Temperature (°F)
February	25
March	35
April	47
May	58
June	67

D

Part II

Directions (31–45): Record your answers in the space provided below each question.

Base your answers to questions 31 and 32 on the chart below and on your knowledge of science. The chart lists several facts about floods.

Flood Facts

- can cause damage to homes
- can deposit nutrient-rich soil
- can occur quickly
- some rivers can flood every year
- can refill groundwater

31 Identify **one** positive environmental impact of flooding. [1]

32 Identify **one** action a person should take to stay safe if a flood is predicted. [1]

33 The data table below shows the number of glass bottles collected by a student while cleaning up a park on four days.

Glass Bottles Collected

Day	Bottles
1	11
2	8
3	5
4	7

Complete the bar graph below to show the student's data for the number of glass bottles collected each day. The bar for Day 1 is shown as an example. [1]

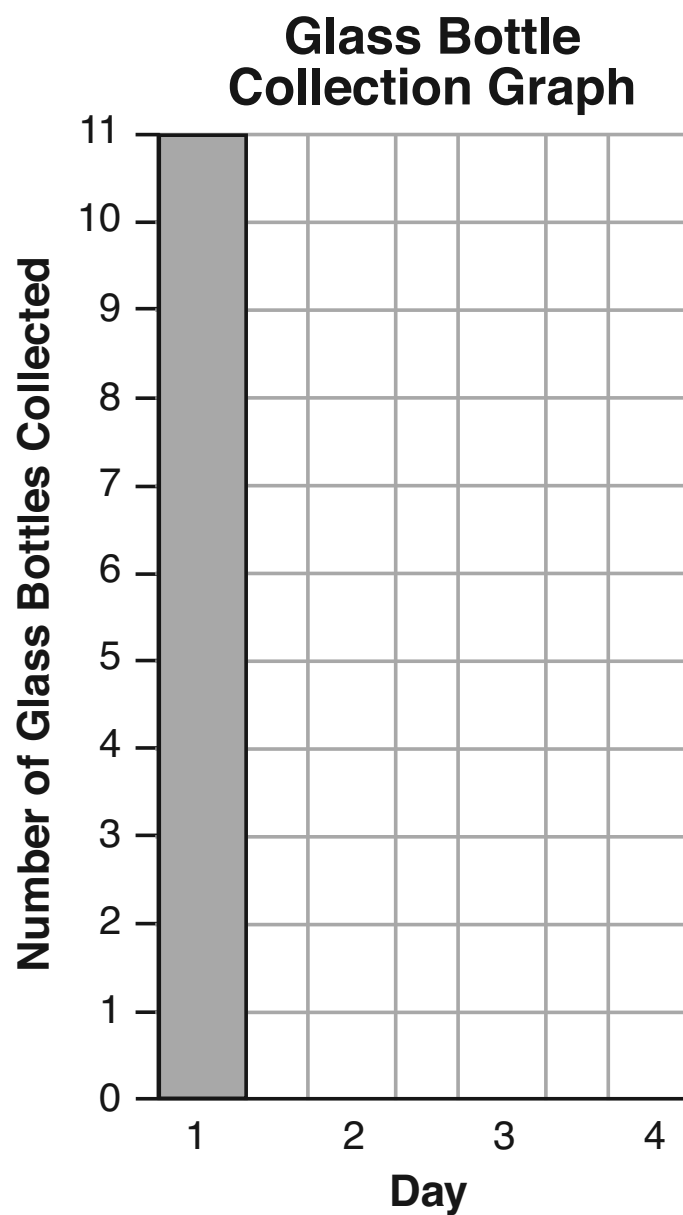

Base your answers to questions 34 and 35 on the diagram below and on your knowledge of science. The diagram shows four different birds with different-sized beaks.

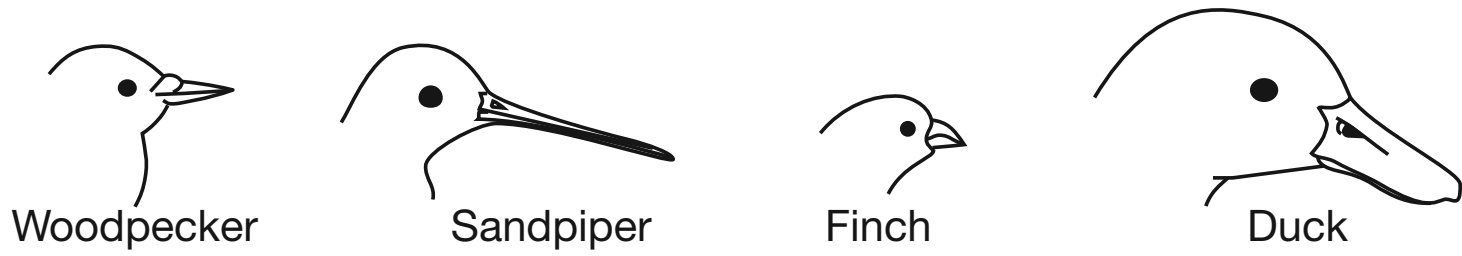

34 Place the birds' names in order from shortest beak to longest beak. [1]



35 Identify **one** scientific tool that could be used to measure the length of a bird's beak. [1]

Base your answers to questions 36 and 37 on the diagrams below and on your knowledge of science. Diagrams A, B, and C show water in its three states of matter.

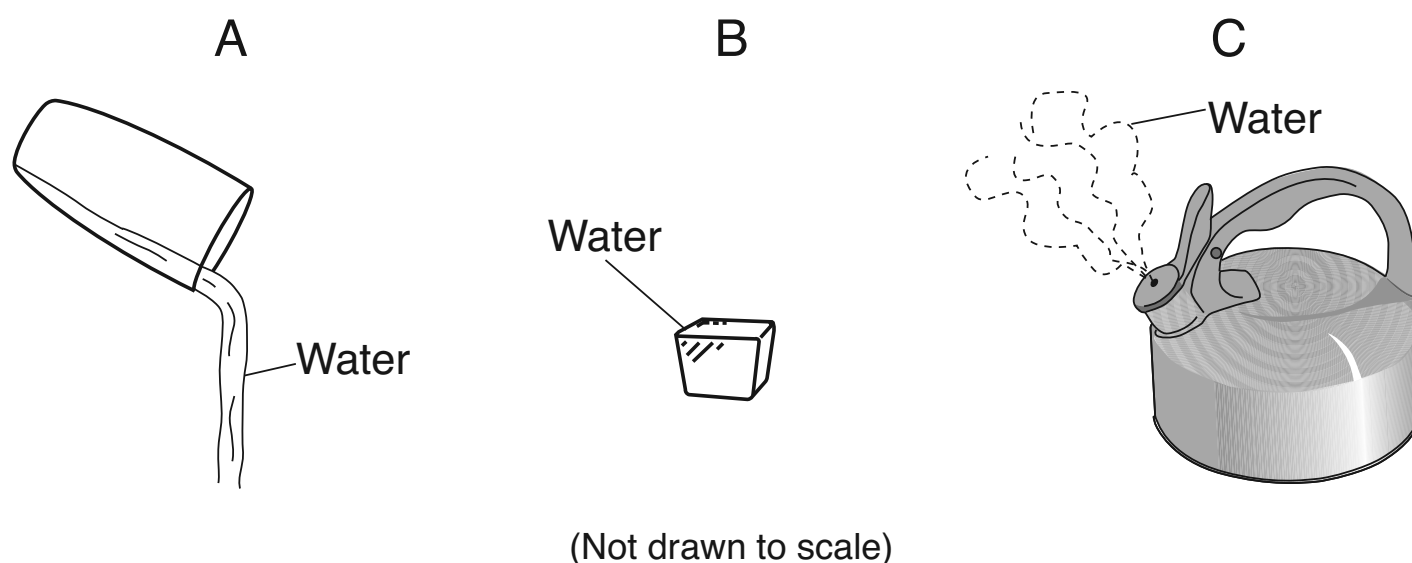

36 Identify the state of matter of water shown in diagram A. [1]

37 Which diagram shows water in the state of matter that has a definite shape and definite volume? [1]

Circle one: A B C

38 The diagram below shows several objects that use electrical energy. People use these objects in different ways.

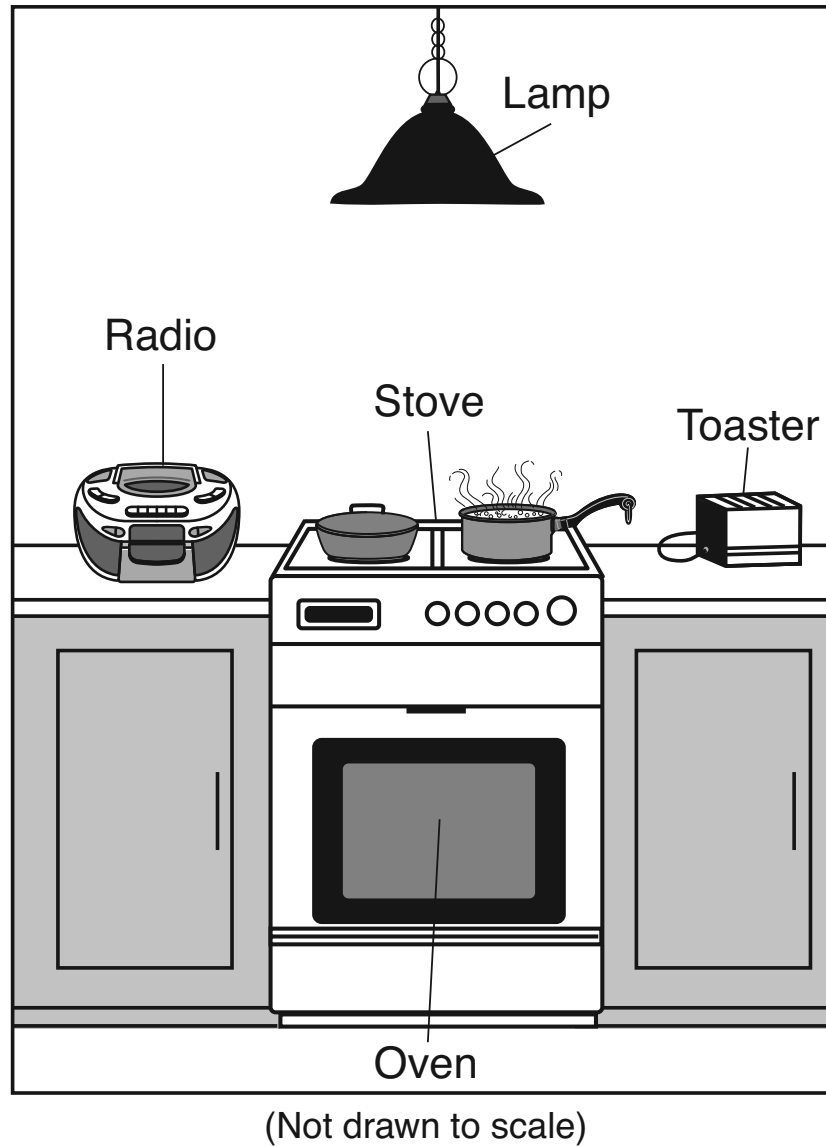

Choose **one** object from the diagram, other than the radio. Identify **one** form of energy the object produces by transforming electrical energy, and then describe how the object helps people. The information for the radio is shown. [1]

Object	Form of Energy Produced	How the Object Helps People
radio	sound	People can hear news and weather reports.

39 The diagram below shows a student rubbing their hands together. The arrows represent the directions that the student’s hands are moving.

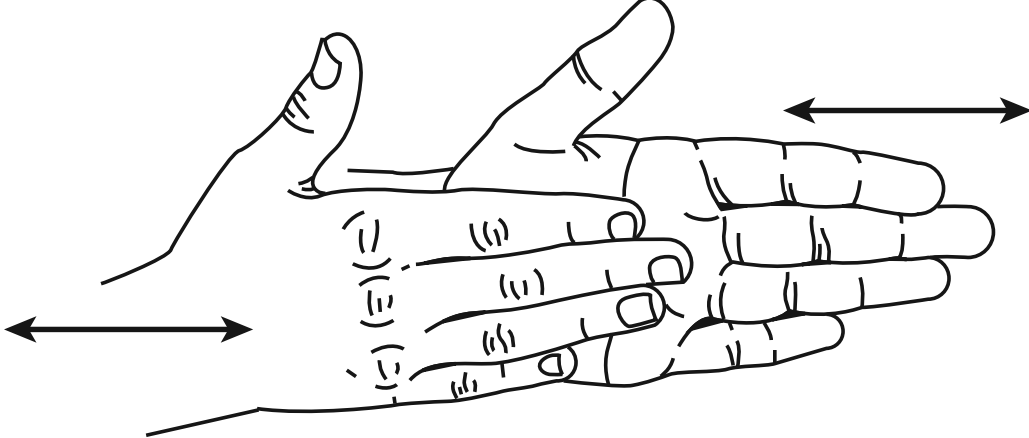

Identify **one** form of energy produced when the student rubs their hands together. [1]

Base your answers to questions 40 and 41 on the diagram below and on your knowledge of science. The diagram shows a skunk.



40 Skunks can spray a liquid with a very strong odor. Identify **one** sense that could be affected when an animal gets sprayed by a skunk. [1]

41 Skunks also have sharp claws. Describe **one** way the skunk's claws help it to survive. [1]

Base your answers to questions 42 and 43 on the diagram of a pond environment below and on your knowledge of science.

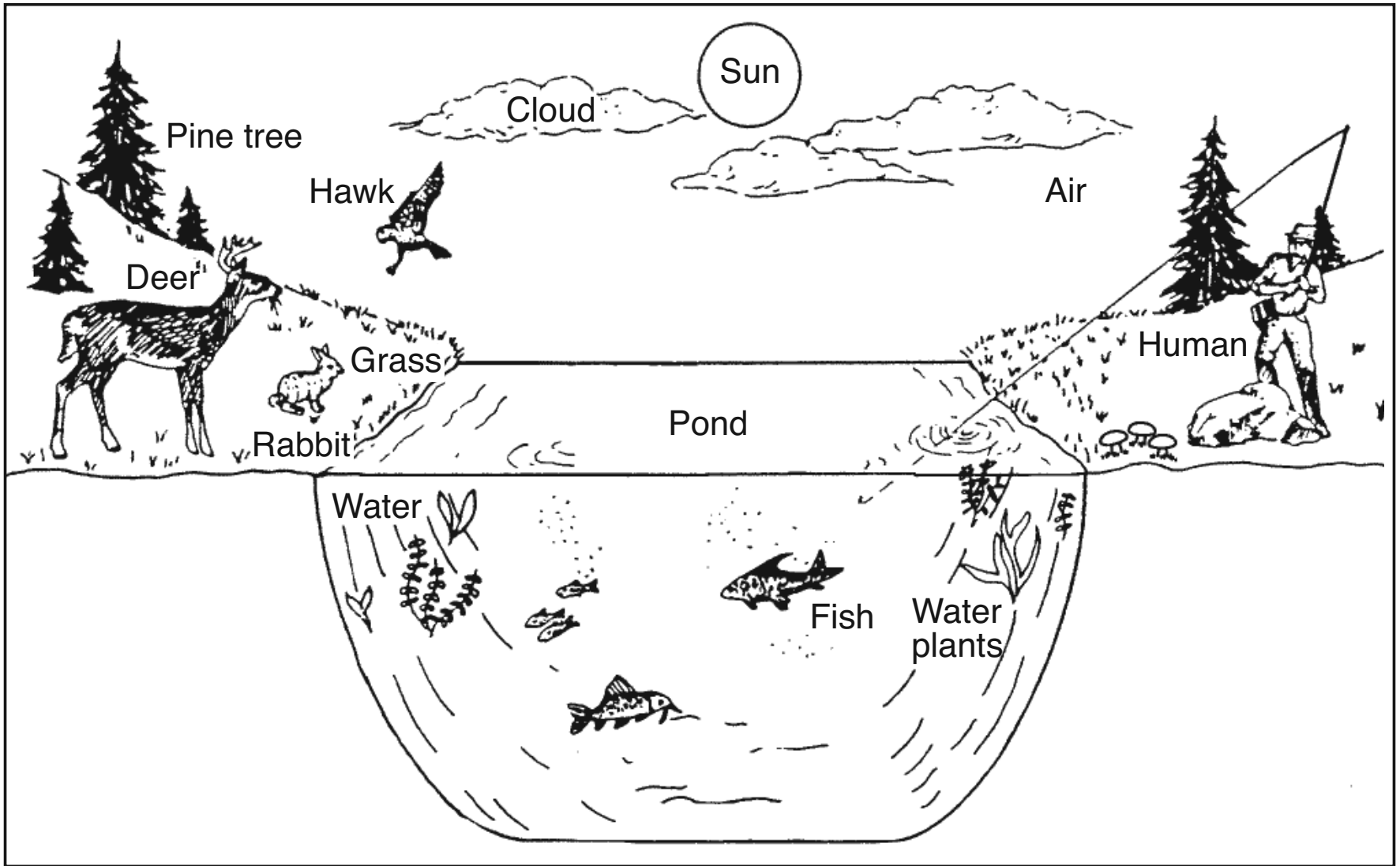

(Not drawn to scale)

42 Identify **two** organisms labeled in the diagram that are producers. [1]

_____ and _____

43 Identify the source of energy for all the organisms in this pond environment. [1]

44 The average life span of one type of animal is ten years. Explain what is meant by life span. [1]

45 Describe **two** reasons why an animal might move from one area to live in another area. [1]

(1) _____

(2) _____

GRADE 4 ELEMENTARY-LEVEL SCIENCE

For Teacher Use Only
Part II Credits

Question	Maximum Credit	Credit Allowed
31	1	
32	1	
33	1	
34	1	
35	1	
36	1	
37	1	
38	1	
39	1	
40	1	
41	1	
42	1	
43	1	
44	1	
45	1	
Total	15	