

The University of the State of New York
REGENTS HIGH SCHOOL EXAMINATION

PHYSICAL SETTING
PHYSICS

Thursday, June 13, 2013 — 1:15 to 4:15 p.m., only

The possession or use of any communications device is strictly prohibited when taking this examination. If you have or use any communications device, no matter how briefly, your examination will be invalidated and no score will be calculated for you.

Answer all questions in all parts of this examination according to the directions provided in the examination booklet.

A separate answer sheet for Part A and Part B-1 has been provided to you. Follow the instructions from the proctor for completing the student information on your answer sheet. Record your answers to the Part A and Part B-1 multiple-choice questions on this separate answer sheet. Record your answers for the questions in Part B-2 and Part C in your separate answer booklet. Be sure to fill in the heading on the front of your answer booklet.

All answers in your answer booklet should be written in pen, except for graphs and drawings, which should be done in pencil. You may use scrap paper to work out the answers to the questions, but be sure to record all your answers on your separate answer sheet or in your answer booklet as directed.

When you have completed the examination, you must sign the statement printed on your separate answer sheet, indicating that you had no unlawful knowledge of the questions or answers prior to the examination and that you have neither given nor received assistance in answering any of the questions during the examination. Your answer sheet and answer booklet cannot be accepted if you fail to sign this declaration.

Notice. . .

A scientific or graphing calculator, a centimeter ruler, a protractor, and a copy of the *2006 Edition Reference Tables for Physical Setting/Physics*, which you may need to answer some questions in this examination, must be available for your use while taking this examination.

DO NOT OPEN THIS EXAMINATION BOOKLET UNTIL THE SIGNAL IS GIVEN.

Part A

Answer all questions in this part.

Directions (1–35): For *each* statement or question, choose the word or expression that, of those given, best completes the statement or answers the question. Some questions may require the use of the *2006 Edition Reference Tables for Physical Setting/Physics*. Record your answers on your separate answer sheet.

- 1 Which term identifies a scalar quantity?
(1) displacement (3) velocity
(2) momentum (4) time
- 2 Two 20.-newton forces act concurrently on an object. What angle between these forces will produce a resultant force with the greatest magnitude?
(1) 0° (3) 90°
(2) 45° (4) 180°
- 3 A car traveling west in a straight line on a highway decreases its speed from 30.0 meters per second to 23.0 meters per second in 2.00 seconds. The car's average acceleration during this time interval is
(1) 3.5 m/s^2 east (3) 13 m/s^2 east
(2) 3.5 m/s^2 west (4) 13 m/s^2 west
- 4 In a race, a runner traveled 12 meters in 4.0 seconds as she accelerated uniformly from rest. The magnitude of the acceleration of the runner was
(1) 0.25 m/s^2 (3) 3.0 m/s^2
(2) 1.5 m/s^2 (4) 48 m/s^2
- 5 A projectile is launched at an angle above the ground. The horizontal component of the projectile's velocity, v_x , is initially 40. meters per second. The vertical component of the projectile's velocity, v_y , is initially 30. meters per second. What are the components of the projectile's velocity after 2.0 seconds of flight? [Neglect friction.]
(1) $v_x = 40. \text{ m/s}$ and $v_y = 10. \text{ m/s}$
(2) $v_x = 40. \text{ m/s}$ and $v_y = 30. \text{ m/s}$
(3) $v_x = 20. \text{ m/s}$ and $v_y = 10. \text{ m/s}$
(4) $v_x = 20. \text{ m/s}$ and $v_y = 30. \text{ m/s}$
- 6 A ball is thrown with an initial speed of 10. meters per second. At what angle above the horizontal should the ball be thrown to reach the greatest height?
(1) 0° (3) 45°
(2) 30° (4) 90°
- 7 Which object has the greatest inertia?
(1) a 0.010-kg bullet traveling at 90. m/s
(2) a 30.-kg child traveling at 10. m/s on her bike
(3) a 490-kg elephant walking with a speed of 1.0 m/s
(4) a 1500-kg car at rest in a parking lot
- 8 An 8.0-newton wooden block slides across a horizontal wooden floor at constant velocity. What is the magnitude of the force of kinetic friction between the block and the floor?
(1) 2.4 N (3) 8.0 N
(2) 3.4 N (4) 27 N
- 9 Which situation represents a person in equilibrium?
(1) a child gaining speed while sliding down a slide
(2) a woman accelerating upward in an elevator
(3) a man standing still on a bathroom scale
(4) a teenager driving around a corner in his car
- 10 A rock is thrown straight up into the air. At the highest point of the rock's path, the magnitude of the net force acting on the rock is
(1) less than the magnitude of the rock's weight, but greater than zero
(2) greater than the magnitude of the rock's weight
(3) the same as the magnitude of the rock's weight
(4) zero

- 11 The diagram below shows a compressed spring between two carts initially at rest on a horizontal, frictionless surface. Cart A has a mass of 2 kilograms and cart B has a mass of 1 kilogram. A string holds the carts together.

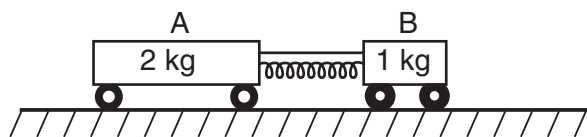

The string is cut and the carts move apart. Compared to the magnitude of the force the spring exerts on cart A, the magnitude of the force the spring exerts on cart B is

- (1) the same
(2) half as great
(3) twice as great
(4) four times as great
- 12 An 8.0-newton block is accelerating down a frictionless ramp inclined at 15° to the horizontal, as shown in the diagram below.

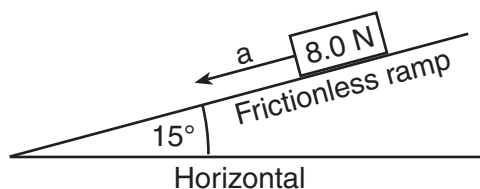

What is the magnitude of the net force causing the block's acceleration?

- (1) 0 N
(2) 2.1 N
(3) 7.7 N
(4) 8.0 N
- 13 At a certain location, a gravitational force with a magnitude of 350 newtons acts on a 70.-kilogram astronaut. What is the magnitude of the gravitational field strength at this location?
- (1) 0.20 kg/N
(2) 5.0 N/kg
(3) 9.8 m/s²
(4) 25 000 N•kg
- 14 A spring gains 2.34 joules of elastic potential energy as it is compressed 0.250 meter from its equilibrium position. What is the spring constant of this spring?
- (1) 9.36 N/m
(2) 18.7 N/m
(3) 37.4 N/m
(4) 74.9 N/m

- 15 When a teacher shines light on a photocell attached to a fan, the blades of the fan turn. The brighter the light shone on the photocell, the faster the blades turn. Which energy conversion is illustrated by this demonstration?

- (1) light \rightarrow thermal \rightarrow mechanical
(2) light \rightarrow nuclear \rightarrow thermal
(3) light \rightarrow electrical \rightarrow mechanical
(4) light \rightarrow mechanical \rightarrow chemical

- 16 Which statement describes a characteristic common to all electromagnetic waves and mechanical waves?

- (1) Both types of waves travel at the same speed.
(2) Both types of waves require a material medium for propagation.
(3) Both types of waves propagate in a vacuum.
(4) Both types of waves transfer energy.

- 17 An electromagnetic wave is produced by charged particles vibrating at a rate of 3.9×10^8 vibrations per second. The electromagnetic wave is classified as

- (1) a radio wave
(2) an infrared wave
(3) an x ray
(4) visible light

- 18 The energy of a sound wave is most closely related to the wave's

- (1) frequency
(2) amplitude
(3) wavelength
(4) speed

- 19 A sound wave traveling eastward through air causes the air molecules to

- (1) vibrate east and west
(2) vibrate north and south
(3) move eastward, only
(4) move northward, only

- 20 What is the speed of light ($f = 5.09 \times 10^{14}$ Hz) in ethyl alcohol?

- (1) 4.53×10^{-9} m/s
(2) 2.43×10^2 m/s
(3) 1.24×10^8 m/s
(4) 2.21×10^8 m/s

21 In the diagram below, an ideal pendulum released from position *A* swings freely to position *B*.

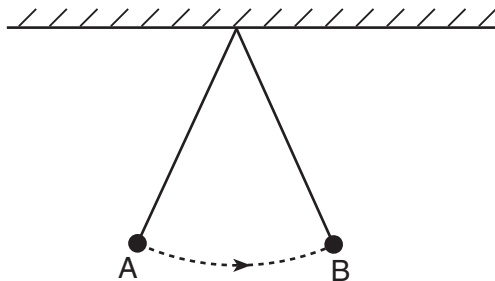

As the pendulum swings from *A* to *B*, its total mechanical energy

- (1) decreases, then increases
- (2) increases, only
- (3) increases, then decreases
- (4) remains the same

22 The diagram below represents a periodic wave.

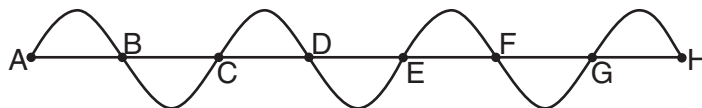

Which two points on the wave are out of phase?

- (1) *A* and *C*
- (2) *B* and *F*
- (3) *C* and *E*
- (4) *D* and *G*

23 A dry plastic rod is rubbed with wool cloth and then held near a thin stream of water from a faucet. The path of the stream of water is changed, as represented in the diagram below.

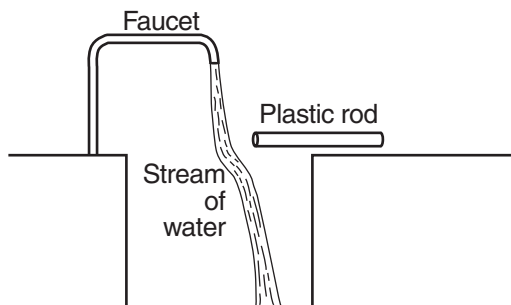

Which force causes the path of the stream of water to change due to the plastic rod?

- (1) nuclear
- (2) magnetic
- (3) electrostatic
- (4) gravitational

24 A distance of 1.0×10^{-2} meter separates successive crests of a periodic wave produced in a shallow tank of water. If a crest passes a point in the tank every 4.0×10^{-1} second, what is the speed of this wave?

- (1) 2.5×10^{-4} m/s (3) 2.5×10^{-2} m/s
(2) 4.0×10^{-3} m/s (4) 4.0×10^{-1} m/s

25 One vibrating 256-hertz tuning fork transfers energy to another 256-hertz tuning fork, causing the second tuning fork to vibrate. This phenomenon is an example of

- (1) diffraction (3) refraction
(2) reflection (4) resonance

26 Sound waves are produced by the horn of a truck that is approaching a stationary observer. Compared to the sound waves detected by the driver of the truck, the sound waves detected by the observer have a greater

- (1) wavelength (3) period
(2) frequency (4) speed

27 The electronvolt is a unit of

- (1) energy
(2) charge
(3) electric field strength
(4) electric potential difference

28 Which particle would produce a magnetic field?

- (1) a neutral particle moving in a straight line
(2) a neutral particle moving in a circle
(3) a stationary charged particle
(4) a moving charged particle

29 A physics student takes her pulse and determines that her heart beats periodically 60 times in 60 seconds. The period of her heartbeat is

- (1) 1 Hz (3) 1 s
(2) 60 Hz (4) 60 s

30 Moving 4.0 coulombs of charge through a circuit requires 48 joules of electric energy. What is the potential difference across this circuit?

- (1) 190 V (3) 12 V
(2) 48 V (4) 4.0 V

31 The diagram below shows currents in a segment of an electric circuit.

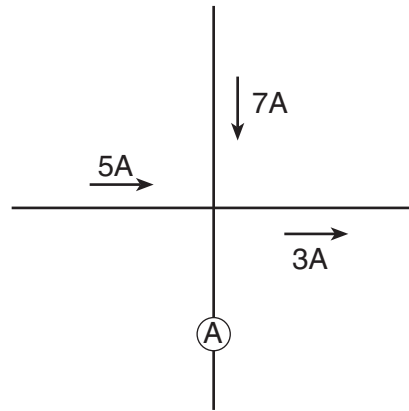

What is the reading of ammeter A?

- (1) 1 A (3) 9 A
(2) 5 A (4) 15 A

32 An electric dryer consumes 6.0×10^6 joules of electrical energy when operating at 220 volts for 1.8×10^3 seconds. During operation, the dryer draws a current of

- (1) 10. A (3) 9.0×10^2 A
(2) 15 A (4) 3.3×10^3 A

33 Which net charge could be found on an object?

- (1) $+4.80 \times 10^{-19}$ C (3) -2.40×10^{-19} C
(2) $+2.40 \times 10^{-19}$ C (4) -5.60×10^{-19} C

34 A photon is emitted as the electron in a hydrogen atom drops from the $n = 5$ energy level directly to the $n = 3$ energy level. What is the energy of the emitted photon?

- (1) 0.85 eV (3) 1.51 eV
(2) 0.97 eV (4) 2.05 eV

35 In a process called pair production, an energetic gamma ray is converted into an electron and a positron. It is *not* possible for a gamma ray to be converted into two electrons because

- (1) charge must be conserved
(2) momentum must be conserved
(3) mass-energy must be conserved
(4) baryon number must be conserved

Part B-1

Answer all questions in this part.

Directions (36–50): For each statement or question, choose the word or expression that, of those given, best completes the statement or answers the question. Some questions may require the use of the 2006 Edition Reference Tables for Physical Setting/Physics. Record your answers on your separate answer sheet.

- 36 The approximate length of an unsharpened No. 2 pencil is
- (1) 2.0×10^{-2} m (3) 2.0×10^0 m
 (2) 2.0×10^{-1} m (4) 2.0×10^1 m

- 37 The diagram below shows an 8.0-kilogram cart moving to the right at 4.0 meters per second about to make a head-on collision with a 4.0-kilogram cart moving to the left at 6.0 meters per second.

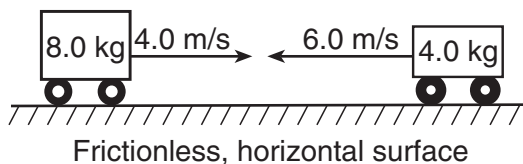

- After the collision, the 4.0-kilogram cart moves to the right at 3.0 meters per second. What is the velocity of the 8.0-kilogram cart after the collision?
- (1) 0.50 m/s left (3) 5.5 m/s left
 (2) 0.50 m/s right (4) 5.5 m/s right

- 38 Four forces act concurrently on a block on a horizontal surface as shown in the diagram below.

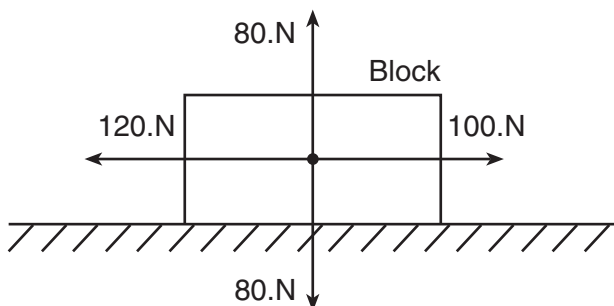

- As a result of these forces, the block
- (1) moves at constant speed to the right
 (2) moves at constant speed to the left
 (3) accelerates to the right
 (4) accelerates to the left

- 39 If a motor lifts a 400.-kilogram mass a vertical distance of 10. meters in 8.0 seconds, the *minimum* power generated by the motor is
- (1) 3.2×10^2 W (3) 4.9×10^3 W
 (2) 5.0×10^2 W (4) 3.2×10^4 W

- 40 A 4.0-kilogram object is accelerated at 3.0 meters per second² north by an unbalanced force. The same unbalanced force acting on a 2.0-kilogram object will accelerate this object toward the north at
- (1) 12 m/s² (3) 3.0 m/s²
 (2) 6.0 m/s² (4) 1.5 m/s²

- 41 An electron is located in an electric field of magnitude 600. newtons per coulomb. What is the magnitude of the electrostatic force acting on the electron?
- (1) 3.75×10^{21} N (3) 9.60×10^{-17} N
 (2) 6.00×10^2 N (4) 2.67×10^{-22} N

- 42 The current in a wire is 4.0 amperes. The time required for 2.5×10^{19} electrons to pass a certain point in the wire is
- (1) 1.0 s (3) 0.50 s
 (2) 0.25 s (4) 4.0 s

- 43 When two point charges of magnitude q_1 and q_2 are separated by a distance, r , the magnitude of the electrostatic force between them is F . What would be the magnitude of the electrostatic force between point charges $2q_1$ and $4q_2$ when separated by a distance of $2r$?
- (1) F (3) $16F$
 (2) $2F$ (4) $4F$

- 44 The composition of a meson with a charge of -1 elementary charge could be
- (1) $s\bar{c}$ (3) $u\bar{b}$
 (2) $d s s$ (4) $\bar{u}\bar{c}\bar{d}$

45 Which graph represents the relationship between the kinetic energy and the speed of a freely falling object?

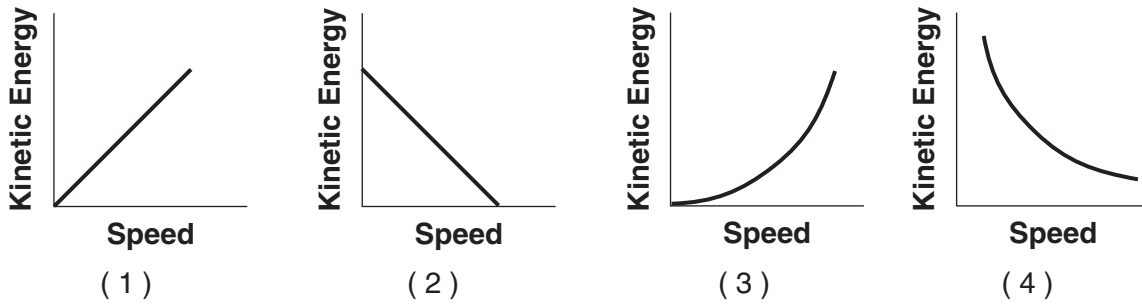

46 Which diagram represents the electric field between two oppositely charged conducting spheres?

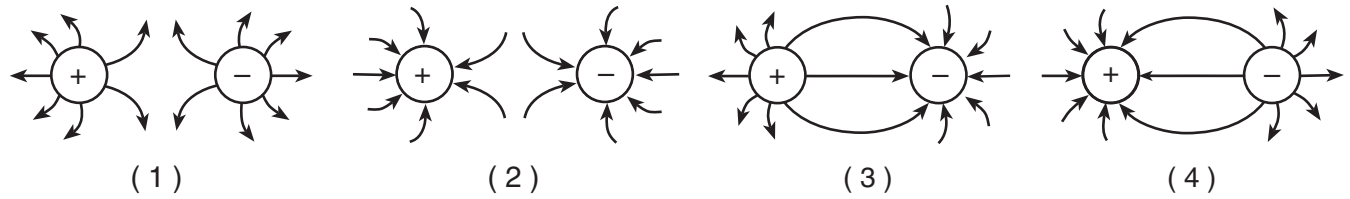

47 Which graph represents the relationship between the magnitude of the gravitational force, F_g , between two masses and the distance, r , between the centers of the masses?

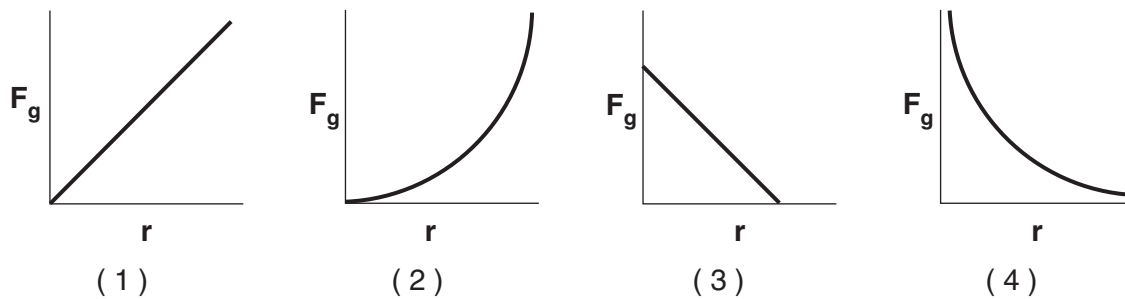

48 The diagram below shows two waves traveling toward each other at equal speed in a uniform medium.

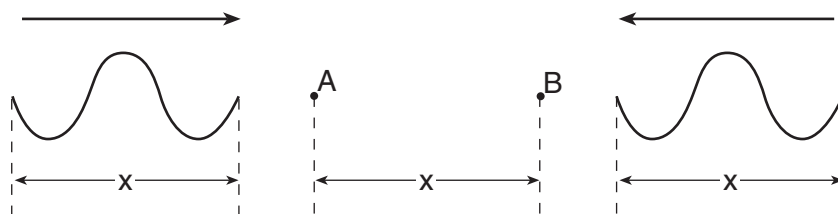

When both waves are in the region between points A and B, they will undergo

- (1) diffraction
- (2) the Doppler effect
- (3) destructive interference
- (4) constructive interference

49 The diagram below shows a series of straight wave fronts produced in a shallow tank of water approaching a small opening in a barrier.

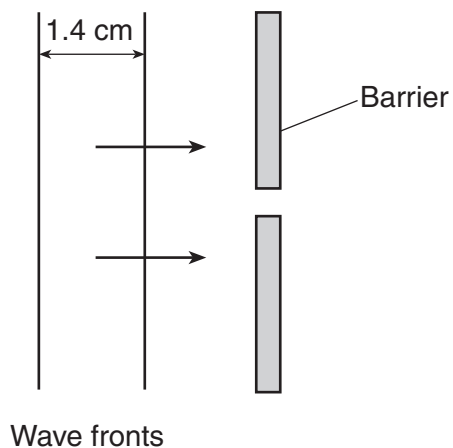

Which diagram represents the appearance of the wave fronts after passing through the opening in the barrier?

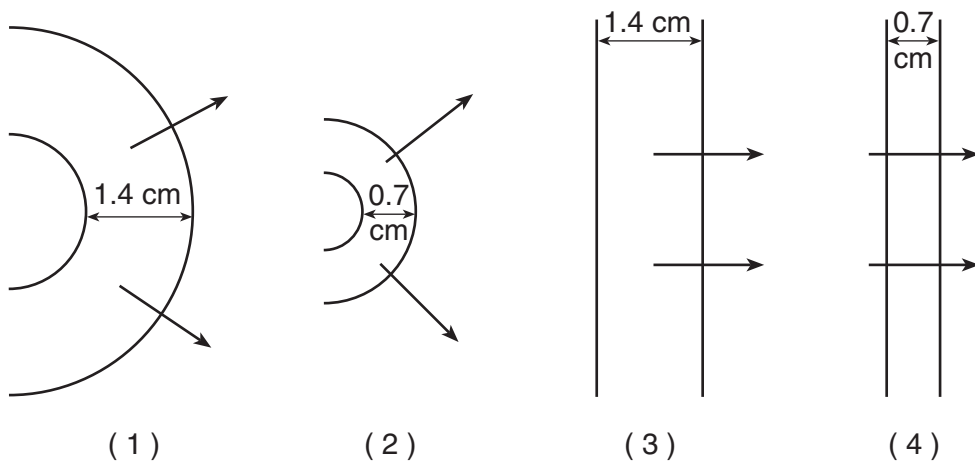

50 The graph below represents the relationship between energy and the equivalent mass from which it can be converted.

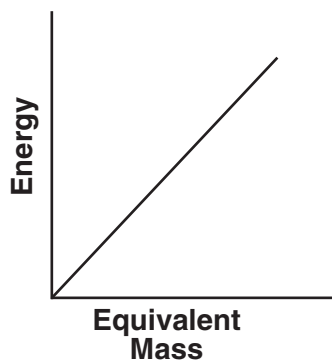

The slope of this graph represents

- (1) c
- (2) c^2
- (3) g
- (4) g^2

Part B-2

Answer all questions in this part.

Directions (51–65): Record your answers in the spaces provided in your answer booklet. Some questions may require the use of the *2006 Edition Reference Tables for Physical Setting/Physics*.

51–52 A 25.0-meter length of platinum wire with a cross-sectional area of 3.50×10^{-6} meter² has a resistance of 0.757 ohm at 20°C. Calculate the resistivity of the wire. [Show all work, including the equation and substitution with units.] [2]

53 The diagram below represents a periodic wave moving along a rope.

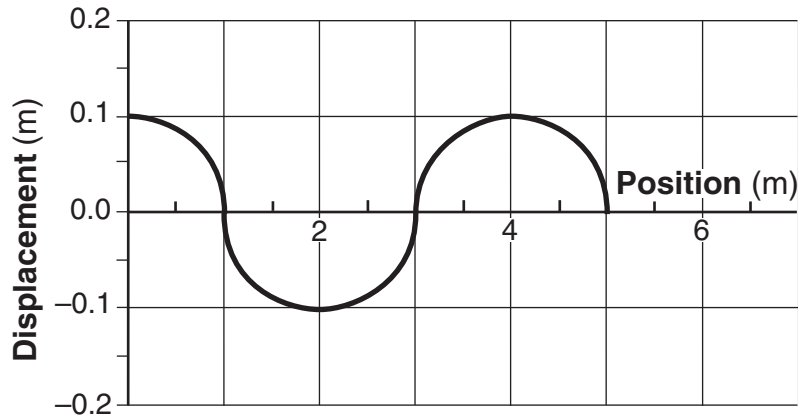

On the grid in your answer booklet, draw at least one full wave with the same amplitude and half the wavelength of the given wave. [1]

54–55 A baseball bat exerts an average force of 600. newtons east on a ball, imparting an impulse of 3.6 newton•seconds east to the ball. Calculate the amount of time the baseball bat is in contact with the ball. [Show all work, including the equation and substitution with units.] [2]

56 The diagram below shows the north pole of one bar magnet located near the south pole of another bar magnet.



On the diagram in your answer booklet, draw three magnetic field lines in the region between the magnets. [1]

Base your answers to questions 57 through 59 on the information and graph below.

The graph below shows the relationship between speed and elapsed time for a car moving in a straight line.

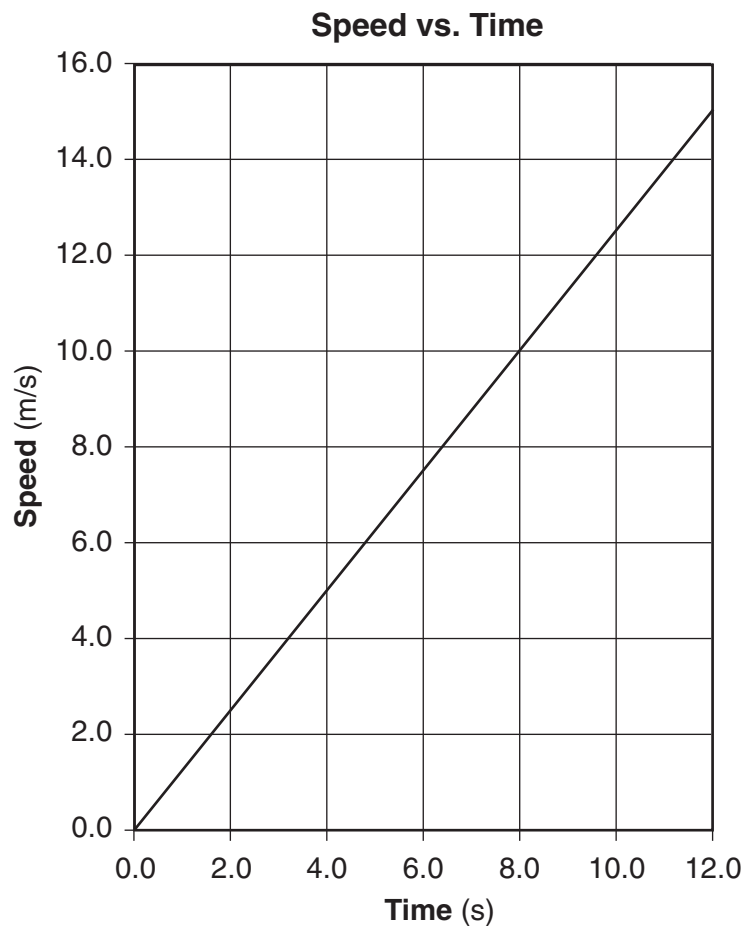

57 Determine the magnitude of the acceleration of the car. [1]

58–59 Calculate the total distance the car traveled during the time interval 4.0 seconds to 8.0 seconds.
[Show all work, including the equation and substitution with units.] [2]

Base your answers to questions 60 through 62 on the information below.

A 20.-ohm resistor, R_1 , and a resistor of unknown resistance, R_2 , are connected in parallel to a 30.-volt source, as shown in the circuit diagram below. An ammeter in the circuit reads 2.0 amperes.

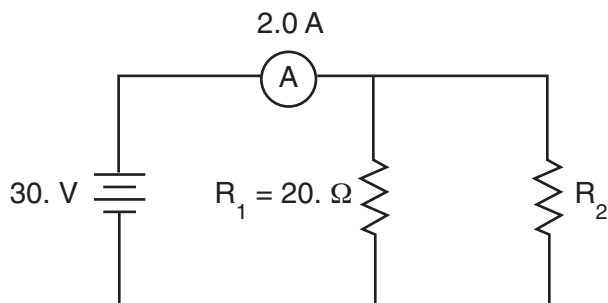

60 Determine the equivalent resistance of the circuit. [1]

61–62 Calculate the resistance of resistor R_2 . [Show all work, including the equation and substitution with units.] [2]

Base your answers to questions 63 through 65 on the information below.

A 28-gram rubber stopper is attached to a string and whirled clockwise in a horizontal circle with a radius of 0.80 meter. The diagram in your answer booklet represents the motion of the rubber stopper. The stopper maintains a constant speed of 2.5 meters per second.

63–64 Calculate the magnitude of the centripetal acceleration of the stopper. [Show all work, including the equation and substitution with units.] [2]

65 On the diagram *in your answer booklet*, draw an arrow showing the direction of the centripetal force acting on the stopper when it is at the position shown. [1]

Part C

Answer all questions in this part.

Directions (66–85): Record your answers in the spaces provided in your answer booklet. Some questions may require the use of the *2006 Edition Reference Tables for Physical Setting/Physics*.

Base your answers to questions 66 through 69 on the information below.

Auroras over the polar regions of Earth are caused by collisions between charged particles from the Sun and atoms in Earth's atmosphere. The charged particles give energy to the atoms, exciting them from their lowest available energy level, the ground state, to higher energy levels, excited states. Most atoms return to their ground state within 10. nanoseconds.

In the higher regions of Earth's atmosphere, where there are fewer interatom collisions, a few of the atoms remain in excited states for longer times. For example, oxygen atoms remain in an excited state for up to 1.0 second. These atoms account for the greenish and red glows of the auroras. As these oxygen atoms return to their ground state, they emit green photons ($f = 5.38 \times 10^{14}$ Hz) and red photons ($f = 4.76 \times 10^{14}$ Hz). These emissions last long enough to produce the changing aurora phenomenon.

66 What is the order of magnitude of the time, in seconds, that most atoms spend in an excited state? [1]

67–68 Calculate the energy of a photon, in joules, that accounts for the red glow of the aurora. [Show all work, including the equation and substitution with units.] [2]

69 Explain what is meant by an atom being in its ground state. [1]

Base your answers to questions 70 through 75 on the information below.

A girl rides her bicycle 1.40 kilometers west, 0.70 kilometer south, and 0.30 kilometer east in 12 minutes. The vector diagram in your answer booklet represents the girl's first two displacements in sequence from point P . The scale used in the diagram is 1.0 centimeter = 0.20 kilometer.

70–71 On the vector diagram *in your answer booklet*, using a ruler and a protractor, construct the following vectors:

- Starting at the arrowhead of the second displacement vector, draw a vector to represent the 0.30 kilometer east displacement. Label the vector with its magnitude. [1]
- Draw the vector representing the resultant displacement of the girl for the entire bicycle trip *and* label the vector R . [1]

72–73 Calculate the girl's average speed for the entire bicycle trip. [Show all work, including the equation and substitution with units.] [2]

74 Determine the magnitude of the girl's resultant displacement for the entire bicycle trip, in kilometers. [1]

75 Determine the measure of the angle, in degrees, between the resultant and the 1.40-kilometer displacement vector. [1]

Base your answers to questions 76 through 80 on the information below.

A light ray with a frequency of 5.09×10^{14} hertz traveling in water has an angle of incidence of 35° on a water-air interface. At the interface, part of the ray is reflected from the interface and part of the ray is refracted as it enters the air.

76 What is the angle of reflection of the light ray at the interface? [1]

77 On the diagram *in your answer booklet*, using a protractor and a straightedge, draw the reflected ray. [1]

78–79 Calculate the angle of refraction of the light ray as it enters the air. [Show all work, including the equation and substitution with units.] [2]

80 Identify *one* characteristic of this light ray that is the same in *both* the water and the air. [1]

Base your answers to questions 81 through 85 on the information and diagram below.

A 30.4-newton force is used to slide a 40.0-newton crate a distance of 6.00 meters at constant speed along an incline to a vertical height of 3.00 meters.

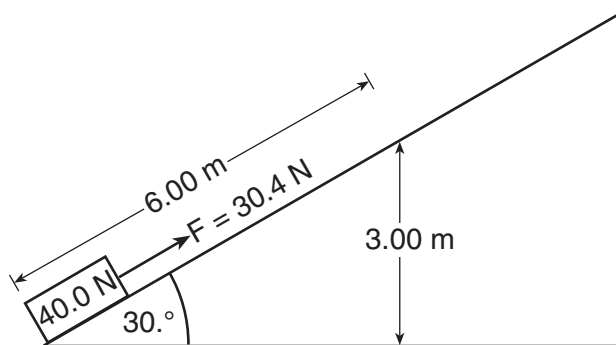

81 Determine the total work done by the 30.4-newton force in sliding the crate along the incline. [1]

82–83 Calculate the total increase in the gravitational potential energy of the crate after it has slid 6.00 meters along the incline. [Show all work, including the equation and substitution with units.] [2]

84 State what happens to the kinetic energy of the crate as it slides along the incline. [1]

85 State what happens to the internal energy of the crate as it slides along the incline. [1]
