

The University of the State of New York
REGENTS HIGH SCHOOL EXAMINATION

PHYSICAL SETTING
PHYSICS

Tuesday, June 19, 2018 — 1:15 to 4:15 p.m., only

The possession or use of any communications device is strictly prohibited when taking this examination. If you have or use any communications device, no matter how briefly, your examination will be invalidated and no score will be calculated for you.

Answer all questions in all parts of this examination according to the directions provided in the examination booklet.

A separate answer sheet for Part A and Part B-1 has been provided to you. Follow the instructions from the proctor for completing the student information on your answer sheet. Record your answers to the Part A and Part B-1 multiple-choice questions on this separate answer sheet. Record your answers for the questions in Part B-2 and Part C in your separate answer booklet. Be sure to fill in the heading on the front of your answer booklet.

All answers in your answer booklet should be written in pen, except for graphs and drawings, which should be done in pencil. You may use scrap paper to work out the answers to the questions, but be sure to record all your answers on your separate answer sheet or in your answer booklet as directed.

When you have completed the examination, you must sign the statement printed on your separate answer sheet, indicating that you had no unlawful knowledge of the questions or answers prior to the examination and that you have neither given nor received assistance in answering any of the questions during the examination. Your answer sheet and answer booklet cannot be accepted if you fail to sign this declaration.

Notice. . .

A scientific or graphing calculator, a centimeter ruler, a protractor, and a copy of the *2006 Edition Reference Tables for Physical Setting/Physics*, which you may need to answer some questions in this examination, must be available for your use while taking this examination.

DO NOT OPEN THIS EXAMINATION BOOKLET UNTIL THE SIGNAL IS GIVEN.

Part A

Answer all questions in this part.

Directions (1–35): For each statement or question, choose the word or expression that, of those given, best completes the statement or answers the question. Some questions may require the use of the *2006 Edition Reference Tables for Physical Setting/Physics*. Record your answers on your separate answer sheet.

- 1 Which combination correctly pairs a vector quantity with its corresponding unit?
- (1) weight and kg
 - (2) velocity and m/s
 - (3) speed and m/s
 - (4) acceleration and m^2/s
- 2 A 12.0-kilogram cart is moving at a speed of 0.25 meter per second. After the speed of the cart is tripled, the inertia of the cart will be
- (1) unchanged
 - (2) one-third as great
 - (3) three times greater
 - (4) nine times greater
- 3 While taking off from an aircraft carrier, a jet starting from rest accelerates uniformly to a final speed of 40. meters per second on a runway that is 70. meters long. What is the magnitude of the acceleration of the jet?
- (1) 0.29 m/s^2
 - (2) 0.57 m/s^2
 - (3) 1.8 m/s^2
 - (4) 11 m/s^2
- 4 A 6.0-kilogram cart initially traveling at 4.0 meters per second east accelerates uniformly at $0.50 \text{ meter per second squared}$ east for 3.0 seconds. What is the speed of the cart at the end of this 3.0 second interval?
- (1) 1.5 m/s
 - (2) 5.5 m/s
 - (3) 3.0 m/s
 - (4) 7.0 m/s
- 5 A soccer ball is kicked into the air from level ground with an initial speed of 20. meters per second and returns to ground level. At which angle above the horizontal should the ball be kicked in order for the ball to travel the greatest total horizontal distance? [Neglect friction.]
- (1) 15°
 - (2) 30°
 - (3) 45°
 - (4) 75°
- 6 Starting from rest, a car travels 18 meters as it accelerates uniformly for 3.0 seconds. What is the magnitude of the car's acceleration?
- (1) 6.0 m/s^2
 - (2) 2.0 m/s^2
 - (3) 3.0 m/s^2
 - (4) 4.0 m/s^2
- 7 A ball is rolling horizontally at 3.00 meters per second as it leaves the edge of a tabletop 0.750 meter above the floor. The ball lands on the floor 0.391 second after leaving the tabletop. What is the magnitude of the ball's acceleration 0.200 second after it leaves the tabletop? [Neglect friction.]
- (1) 1.96 m/s^2
 - (2) 7.65 m/s^2
 - (3) 9.81 m/s^2
 - (4) 15.3 m/s^2
- 8 A projectile with mass m is fired with initial horizontal velocity v_x from height h above level ground. Which change would have resulted in a greater time of flight for the projectile? [Neglect friction.]
- (1) decreasing the mass to $m/2$
 - (2) decreasing the height to $h/2$
 - (3) increasing the initial horizontal velocity to $2v_x$
 - (4) increasing the height to $2h$
- 9 A golf club hits a stationary 0.050-kilogram golf ball with an average force of 5.0×10^3 newtons, accelerating the ball to a speed of 44 meters per second. What is the magnitude of the impulse imparted to the ball by the golf club?
- (1) $2.2 \text{ N}\cdot\text{s}$
 - (2) $880 \text{ N}\cdot\text{s}$
 - (3) $1.1 \times 10^4 \text{ N}\cdot\text{s}$
 - (4) $2.2 \times 10^5 \text{ N}\cdot\text{s}$
- 10 A tennis player's racket applies an average force of 200. newtons to a tennis ball for 0.025 second. The average force exerted on the racket by the tennis ball is
- (1) 0.025 N
 - (2) 5.0 N
 - (3) 200. N
 - (4) 80.0 N

- 11 The diagram below represents a box sliding down an incline at constant velocity.

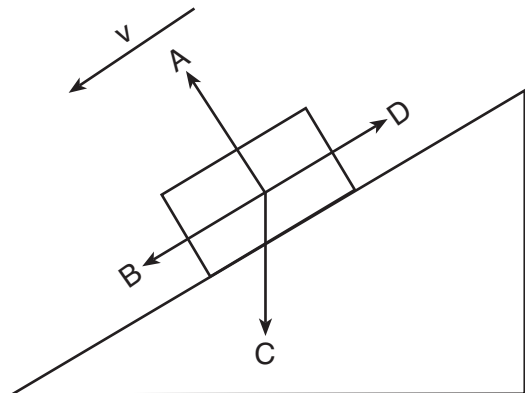

Which arrow represents the direction of the frictional force acting on the box?

- (1) A (3) C
 (2) B (4) D
- 12 Which diagram represents the directions of the velocity, v , and acceleration, a , of a toy car as it moves in a clockwise, horizontal, circular path at a constant speed?

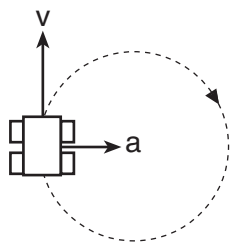

(1)

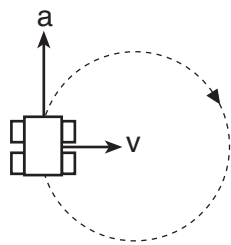

(3)

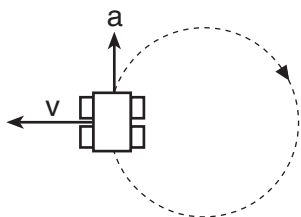

(2)

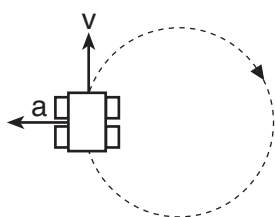

(4)

- 13 A charged particle is located in an electric field where the magnitude of the electric field strength is 2.0×10^3 newtons per coulomb. If the magnitude of the electrostatic force exerted on the particle is 3.0×10^{-3} newton, what is the charge of the particle?

- (1) 1.6×10^{-19} C (3) 6.0 C
 (2) 1.5×10^{-6} C (4) 6.7×10^5 C

- 14 The magnitude of the gravitational field strength near Earth's surface is represented by

- (1) $\frac{F_g}{m}$ (3) mg
 (2) G (4) $\frac{Gm_1m_2}{r^2}$

- 15 A car engine supplies 2.0×10^3 joules of energy during the 10. seconds it takes to accelerate the car along a horizontal surface. What is the average power developed by the car engine while it is accelerating?

- (1) 2.0×10^1 W (3) 2.0×10^3 W
 (2) 2.0×10^2 W (4) 2.0×10^4 W

- 16 Which forces can be either attractive or repulsive?

- (1) gravitational and magnetic
 (2) electrostatic and gravitational
 (3) magnetic and electrostatic
 (4) gravitational, magnetic, and electrostatic

- 17 Compared to the resistivity of a 0.4-meter length of 1-millimeter-diameter copper wire at 0°C , the resistivity of a 0.8-meter length of 1-millimeter-diameter copper wire at 0°C is

- (1) one-fourth as great (3) the same
 (2) one-half as great (4) four times greater

- 18 The work per unit charge required to move a charge between two points in an electric circuit defines electric

- (1) force
 (2) power
 (3) field strength
 (4) potential difference

- 32 A spring has an unstretched length of 0.40 meter. The spring is stretched to a length of 0.60 meter when a 10.-newton weight is hung motionless from one end. The spring constant of this spring is
- (1) 10. N/m
 (2) 17 N/m
 (3) 25 N/m
 (4) 50. N/m

- 33 An electric circuit contains a battery, three lamps, and an open switch, as represented in the diagram below.

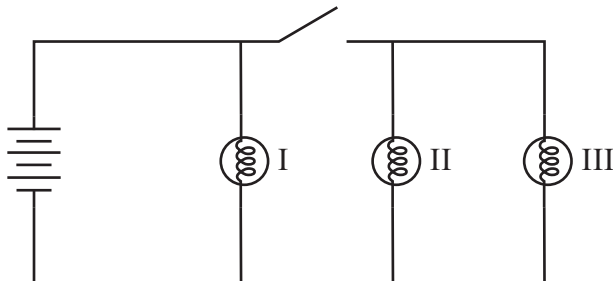

When the switch is open, there is an electric current in

- (1) lamp I, only
 (2) lamps II and III, only
 (3) lamps I, II, and III
 (4) none of the lamps
- 34 Which diagram correctly represents an electric field?

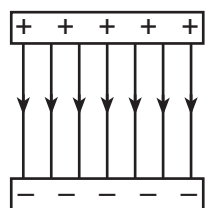

(1)

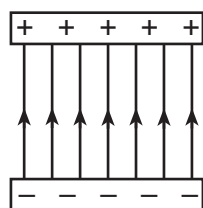

(2)

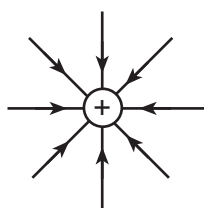

(3)

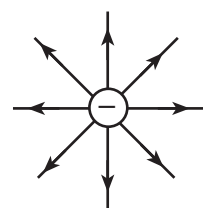

(4)

- 35 Which points on the wave diagram below are 90° out of phase with each other?

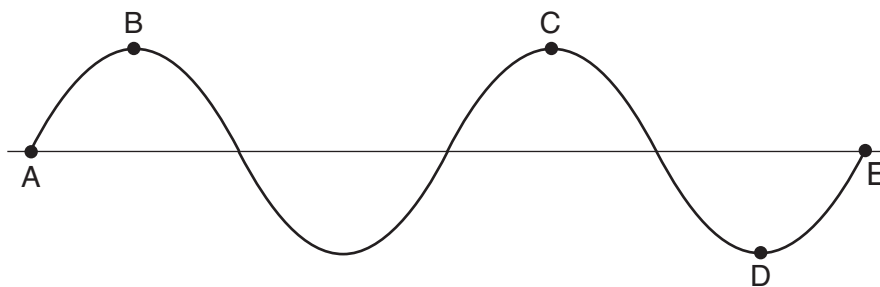

- (1) A and E
 (2) B and C
 (3) C and D
 (4) D and E
-

Part B-1

Answer all questions in this part.

Directions (36–50): For each statement or question, choose the word or expression that, of those given, best completes the statement or answers the question. Some questions may require the use of the 2006 Edition Reference Tables for Physical Setting/Physics. Record your answers on your separate answer sheet.

36 The height of an individual step on a staircase is closest to

- (1) 2.0×10^{-2} m (3) 2.0×10^0 m
(2) 2.0×10^{-1} m (4) 2.0×10^1 m

37 What is the magnitude of the electrostatic force exerted on an electron by another electron when they are 0.10 meter apart?

- (1) 2.6×10^{-36} N (3) 2.3×10^{-26} N
(2) 2.3×10^{-27} N (4) 1.4×10^{-8} N

38 After a 65-newton weight has fallen freely from rest a vertical distance of 5.3 meters, the kinetic energy of the weight is

- (1) 12 J (3) 910 J
(2) 340 J (4) 1800 J

39 A 0.500-kilogram cart traveling to the right on a horizontal, frictionless surface at 2.20 meters per second collides head on with a 0.800-kilogram cart moving to the left at 1.10 meters per second. What is the magnitude of the total momentum of the two-cart system after the collision?

- (1) 0.22 kg•m/s (3) 1.98 kg•m/s
(2) 0.39 kg•m/s (4) 4.29 kg•m/s

40 An object weighing 2.0 newtons is pushed across a horizontal, frictionless surface by a horizontal force of 4.0 newtons. The magnitude of the net force acting on the object is

- (1) 0.0 N (3) 8.0 N
(2) 2.0 N (4) 4.0 N

41 The ratio of the wavelength of AM radio waves traveling in a vacuum to the wavelength of FM radio waves traveling in a vacuum is approximately

- (1) 1 to 1 (3) 10^2 to 1
(2) 2 to 1 (4) 10^8 to 1

42 A charm quark has a charge of approximately

- (1) 5.33×10^{-20} C (3) 1.60×10^{-19} C
(2) 1.07×10^{-19} C (4) 2.40×10^{-19} C

43 The diagram below represents a 3.0-ohm resistor connected to a 12-volt battery. Meters X and Y are correctly connected in the circuit.

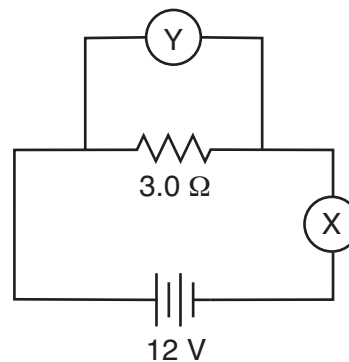

What are the readings on the meters?

- (1) $X = 12$ V and $Y = 0.25$ A
(2) $X = 12$ V and $Y = 4.0$ A
(3) $X = 0.25$ A and $Y = 12$ V
(4) $X = 4.0$ A and $Y = 12$ V

44 A toy airplane, flying in a horizontal, circular path, completes 10. complete circles in 30. seconds. If the radius of the plane's circular path is 4.0 meters, the average speed of the airplane is

- (1) 0.13 m/s (3) 1.3 m/s
(2) 0.84 m/s (4) 8.4 m/s

45 Which pair of graphs represents the vertical motion of an object falling freely from rest?

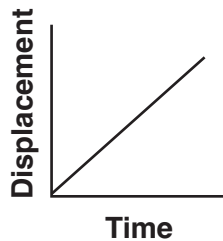

(1)

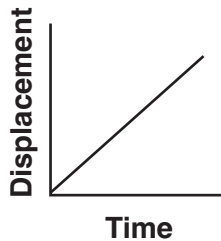
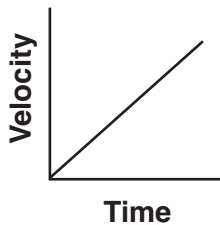

(3)

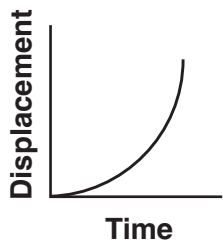
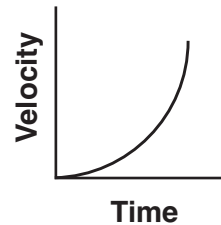

(2)

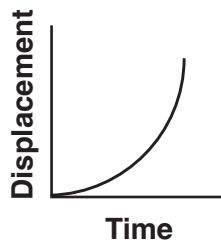
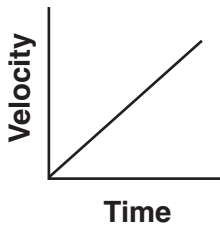

(4)

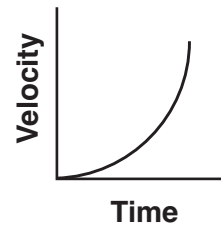

46 An object is thrown straight upward. Which graph best represents the relationship between the object's kinetic energy and the height of the object above its release point? [Neglect friction.]

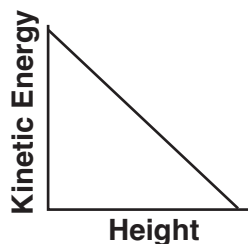

(1)

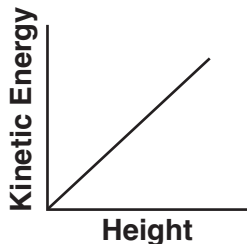

(2)

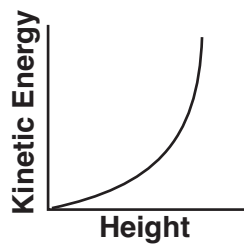

(3)

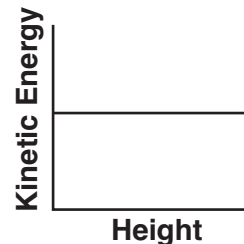

(4)

47 In the diagram below, X represents a particle in a spring.

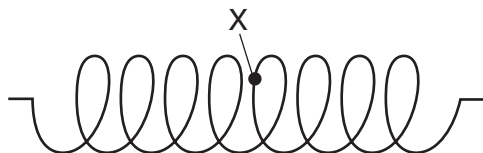

Which diagram represents the motion of particle X as a longitudinal wave passes through the spring toward the right?

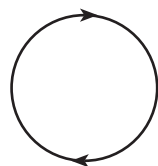

(1)



(2)

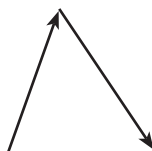

(3)



(4)

Part B-2

Answer all questions in this part.

Directions (51–65): Record your answers in the spaces provided in your answer booklet. Some questions may require the use of the *2006 Edition Reference Tables for Physical Setting/Physics*.

Base your answers to questions 51 through 53 on the information below and on your knowledge of physics.

The scaled diagram below represents two forces acting concurrently at point P . The magnitude of force A is 32 newtons and the magnitude of force B is 20. newtons. The angle between the directions of force A and force B is 120° .

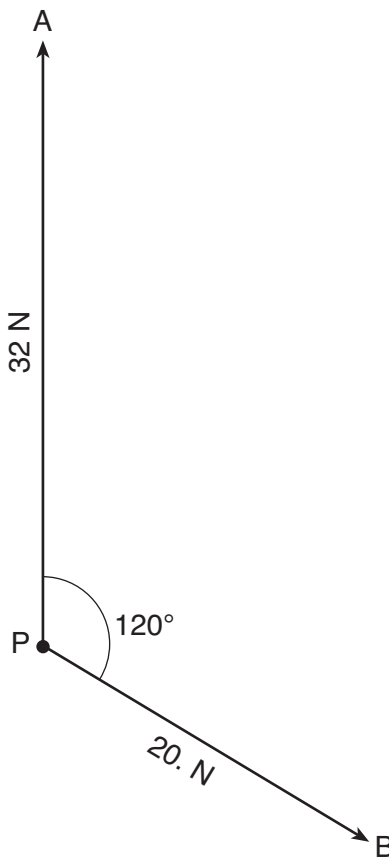

51 Determine the linear scale used in the diagram. [1]

52 On the diagram *in your answer booklet*, use a protractor and a ruler to construct a scaled vector to represent the resultant of forces A and B . Label the vector R . [1]

53 Determine the magnitude of the resultant force. [1]

Base your answers to questions 54 through 56 on the information and diagram below and on your knowledge of physics.

A student pushes a box, weighing 50. newtons, 6.0 meters up an incline at a constant speed by applying a force of 25 newtons parallel to the incline. The top of the incline is 2.0 meters higher than the bottom.

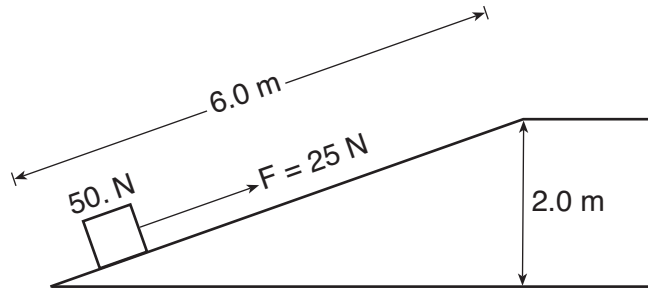

54–55 Calculate the total work done on the box by the student while pushing the box from the bottom to the top of the incline. [Show all work, including the equation and substitution with units.] [2]

56 Describe what would happen to the total work done on the box by the student to push the box 6.0 meters up the incline at constant speed if the coefficient of kinetic friction between the box and the incline were increased. [1]

- 57 In the diagram below, a light ray is incident on an interface between glass and air. When the light strikes the glass-air interface, some of the light is reflected. On the diagram *in your answer booklet*, use a protractor and straightedge to construct the reflected light ray. [1]

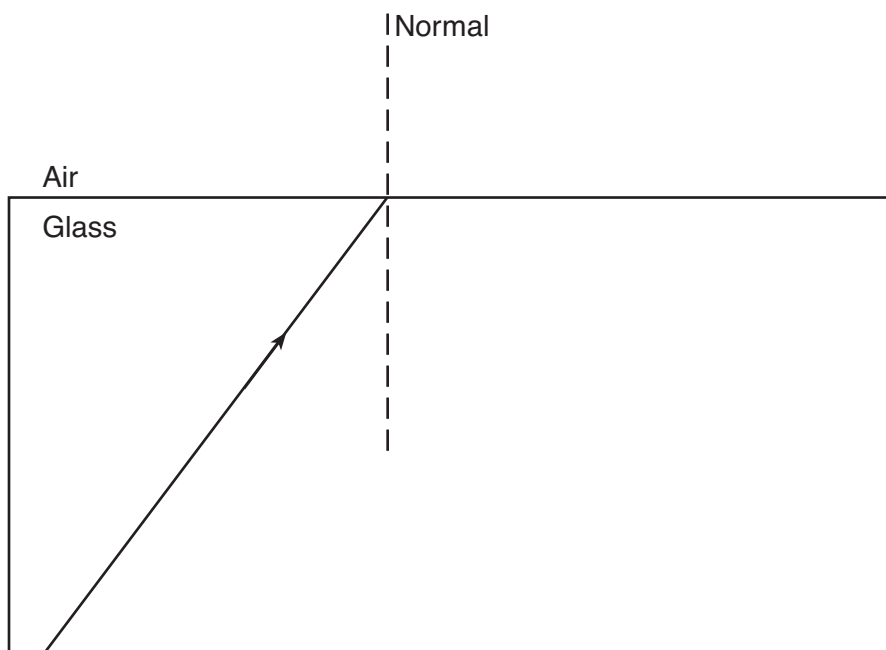

- 58–59 The current in a wire is 5.0 amperes. Calculate the total amount of charge, in coulombs, that travels through the wire in 36 seconds. [Show all work, including the equation and substitution with units.] [2]
- 60–61 A spring, with a spring constant of 100. newtons per meter, possesses 2.0 joules of elastic potential energy when compressed. Calculate the spring's change in length from its uncompressed length. [Show all work, including the equation and substitution with units.] [2]
- 62–63 A monochromatic ray of light ($f = 5.09 \times 10^{14}$ Hz) travels from air into medium X. The angle of incidence of the ray in air is 45.0° and the ray's angle of refraction in medium X is 29.0° . Calculate the absolute index of refraction of medium X. [Show all work, including the equation and substitution with units.] [2]
- 64–65 An argon-ion laser emits blue-green light having a wavelength of 488 nanometers in a vacuum. Calculate the energy of a photon of this light. [Show all work, including the equation and substitution with units.] [2]
-

Part C

Answer all questions in this part.

Directions (66–85): Record your answers in the spaces provided in your answer booklet. Some questions may require the use of the *2006 Edition Reference Tables for Physical Setting/Physics*.

Base your answers to questions 66 through 70 on the information and diagram below and on your knowledge of physics.

An incandescent lightbulb uses a length of thin tungsten wire as the filament (the part of the operating bulb that produces light).

Incandescent Lightbulb

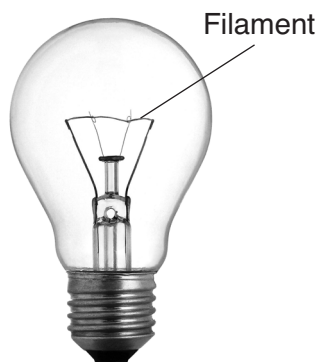

One particular lightbulb has a 0.22-meter length of the tungsten wire used as its filament. This tungsten wire filament has a resistance of 19 ohms at a temperature of 20°C. The tungsten wire filament has a resistance of 240 ohms when this bulb is operated at a potential difference of 120 volts.

- 66–67 Calculate the cross-sectional area of this tungsten wire filament. [Show all work, including the equation and substitution with units.] [2]
- 68 Explain why the resistance of the tungsten wire filament increases when the bulb is being operated compared to the resistance of the filament at 20°C. [1]
- 69–70 Calculate the power of this lightbulb when it is being operated at a potential difference of 120 volts. [Show all work, including the equation and substitution with units.] [2]
-

Base your answers to questions 71 through 75 on the information and diagram below and on your knowledge of physics.

A 150-newton force, applied to a wooden crate at an angle of $30.^\circ$ above the horizontal, causes the crate to travel at constant velocity across a horizontal wooden floor, as represented below.

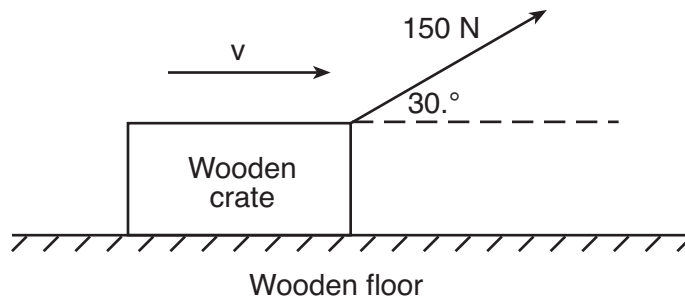

71–72 Calculate the magnitude of the horizontal component of the 150-newton force. [Show all work, including the equation and substitution with units.] [2]

73 Determine the magnitude of the frictional force acting on the crate. [1]

74–75 Calculate the magnitude of the normal force exerted by the floor on the crate. [Show all work, including the equation and substitution with units.] [2]

Base your answers to question 76 through 80 on the information below and on your knowledge of physics.

On a flat, level road, a 1500-kilogram car travels around a curve having a constant radius of 45 meters. The centripetal acceleration of the car has a constant magnitude of 3.2 meters per second squared.

76–77 Calculate the car's speed as it travels around the curve. [Show all work, including the equation and substitution with units.] [2]

78 Determine the magnitude of the centripetal force acting on the car as it travels around the curve. [1]

79 What force provides the centripetal force needed for the car to travel around the curve? [1]

80 Describe what happens to the magnitude of the centripetal force on the car as it travels around the curve if the speed of the car *decreases*. [1]

Base your answers to questions 81 through 85 on the information and diagram below and on your knowledge of physics.

A musician plucks a 0.620-meter-long string on an acoustic guitar, as represented in the diagram below.

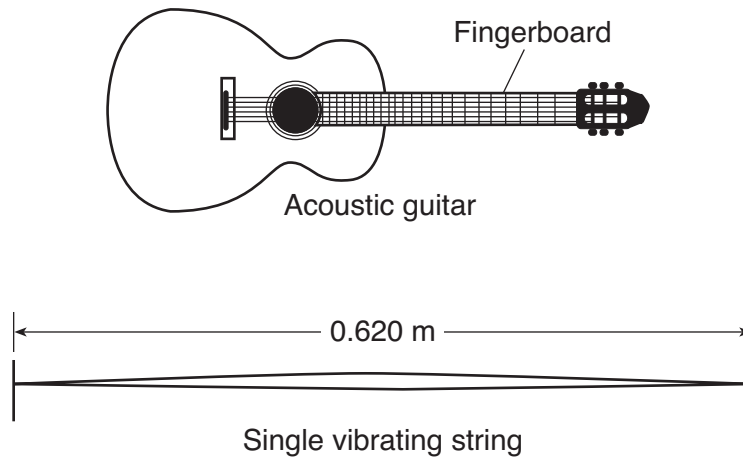

The plucked string vibrates, producing a musical note called “G.” The waves traveling along the vibrating string produce a standing wave with a frequency of 196 hertz.

- 81 On the diagram of the standing wave *in your answer booklet*, label *one* node with the letter **N** and *one* antinode with the letter **A**. [1]
- 82 Determine the wavelength of the standing wave on the 0.620-meter-long vibrating string. [1]
- 83–84 Calculate the speed of the wave traveling on the vibrating string. [Show all work, including the equation and substitution with units.] [2]
- 85 Describe what happens to the frequency when the musician shortens the vibrating portion of the string by pinching the string against the fingerboard while the string continues to vibrate. [1]
-

