



New York State
EDUCATION DEPARTMENT
Knowledge > Skill > Opportunity

**New York State Testing Program
Grade 5
Mathematics Test
(Korean)**

Released Questions

2021

New York State administered the Mathematics Tests in May 2021 and is now making the questions from Session 1 of these tests available for review and use. Only Session 1 was required in 2021.



New York State Testing Program Grades 3–8 Mathematics

Released Questions from 2021 Tests

Background

In 2013, New York State (NYS) began administering tests designed to assess student performance in accordance with the instructional shifts and rigor demanded by the new New York State P–12 Learning Standards in Mathematics. To help in this transition to new assessments, the New York State Education Department (NYSED) has been releasing an increasing number of test questions from the tests that were administered to students across the State in the spring. This year, SED is again releasing 2021 NYS Grades 3–8 English Language Arts and Mathematics test materials for review, discussion, and use.

In February 2021, with the ongoing COVID-19 pandemic still forcing restrictions on all educational and learning activities statewide, NYSED submitted two federal waiver requests related to state assessment and accountability requirements. The waiver requests addressed the unique circumstances caused by the pandemic that have resulted in many students receiving some or all of their instruction remotely.

Later that month, the United States Department of Education (USDE) informed states that it would not grant a blanket waiver for state assessments. However, the USDE agreed to uncouple state assessments from the Every Student Succeeds Act (ESSA) accountability requirements so that test results will be used solely as a measure of student learning. Additionally, it was decided that NYSED would administer only Session 1 of the Grades 3–8 ELA and Mathematics Tests for the Spring 2021 administration and that the tests would include previously administered questions.

The decision to use previously administered test questions in this extraordinary year was based on guidance from nationally recognized experts in the assessment field and was recommended in a [publication](#) from the Council of Chief State School Officers to state education departments. Reusing test questions provided the benefit of having established scale scores and stable item parameters. Using previously administered test questions also ensured that it will be possible to develop new test forms for 2022 and beyond. Although it was not the driver of the decision, the reuse of previously administered test questions provided an opportunity for cost savings during these unique circumstances where the instructional models used by schools varied throughout the State.

For 2021, the entire Session 1 booklet is being released as this is all that students were required to take. Additionally, NYSED is providing a map that details what learning standards each released question measures, and the correct response to each question. These released materials will help students, families, educators, and the public better understand the tests and NYSED's expectations for students.

Understanding Math Questions

Multiple-Choice Questions

Multiple-choice questions are designed to assess the New York State P–12 Learning Standards for Mathematics. Mathematics multiple-choice questions will be used mainly to assess standard algorithms and conceptual standards. Multiple-choice questions incorporate both the grade-level standards and the “Standards for Mathematical Practices.” Many questions are framed within the context of real-world applications or require students to complete multiple steps. Likewise, many of these questions are linked to more than one standard, drawing on the simultaneous application of multiple skills and concepts.

New York State P–12 Learning Standards Alignment

The alignment to the New York State P–12 Learning Standards for Mathematics is intended to identify the primary analytic skills necessary to successfully answer each question. The released questions do not represent the full spectrum of the standards assessed on the State tests, nor do they represent the full spectrum of how the standards should be taught and assessed in the classroom. It should not be assumed that a particular standard will be measured by an identical question in future assessments. Specific criteria for writing test questions, as well as additional assessment information, are available at <http://www.engageny.org/common-core-assessments>.

이름: _____



Korean Edition
Grade 5
Mathematics Test
Session 1
v202

뉴욕주 시험 프로그램
수학 시험
세션 1

5학년

v202



Released Questions

Developed and published under contract with the New York State Education Department by Questar Assessment Inc., 5550 Upper 147th Street West, Minneapolis, MN 55124. Copyright © 2021 by the New York State Education Department.

5학년 수학 참고표

변환

1마일 = 5,280피트

1마일 = 1,760야드

1파운드 = 16온스

1톤 = 2,000파운드

1컵 = 8액량온스

1파인트 = 2컵

1쿼트 = 2파인트

1갤런 = 4쿼트

1리터 = 1,000입방 센티미터

공식

직사각기둥

$$V = Bh \text{ 또는 } V = lwh$$



세션 1



시험 관련 도움말

다음은 자신의 실력을 최고로 발휘하는 데 도움이 되는 사항들입니다.

- 각 문제를 자세히 읽고 답을 선택하기 전에 한 번 더 생각해 보십시오.
- 시험 중에 사용하도록 수학 도구(자와 각도기) 및 참고자료 한장을 제공해 드렸습니다. 각 도구와 참고자료가 언제 유용할지는 본인이 판단해야 합니다. 문제를 푸는 데 도움이 될 것이라고 생각될 때마다 수학 도구와 참고자료 한장을 사용하십시오.

1

선물 상자는 아래 그림과 같이 정사각 기둥의 형태입니다.

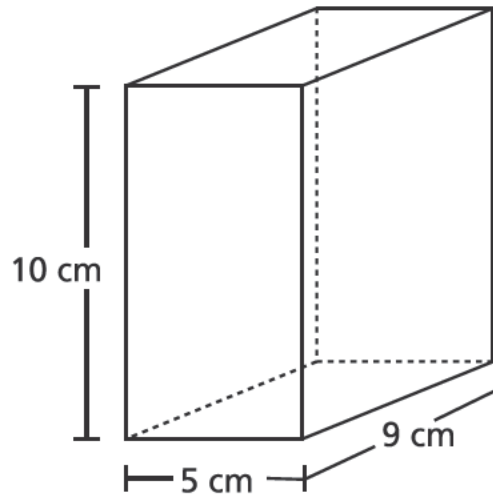

선물 상자의 부피는 몇 세제곱센티미터입니까?

- A 24
- B 45
- C 225
- D 450

2

$\frac{2}{10} + \frac{6}{100}$ 의 합은?

- A $\frac{8}{10}$
- B $\frac{8}{100}$
- C $\frac{26}{10}$
- D $\frac{26}{100}$

계속

3 토요일날 마크는 $2\frac{7}{8}$ 갤런의 레모네이드를 팔았습니다. 같은 날 레건은 마크가 판 레모네이드의 $\frac{2}{3}$ 만큼을 팔았습니다. 레건이 판 레모네이드는 몇 갤런입니까?

- A $1\frac{5}{16}$
- B $1\frac{11}{12}$
- C $2\frac{7}{12}$
- D $4\frac{5}{16}$

4 아래 선분에서 0.75의 값을 나타내는 점은?

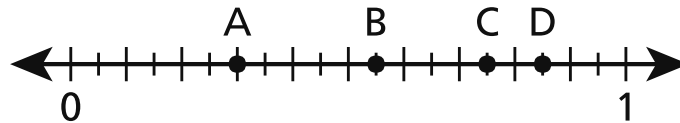

- A 점 A
- B 점 B
- C 점 C
- D 점 D

5 다음 중 참인 비교는?

A $2.919 > 2.94$

B $0.99 < 0.569$

C $1.27 > 1.189$

D $3.861 < 3.75$

6 베티는 고양이 3마리와 개 4마리를 기릅니다. 그녀는 이들에게 각각 한 숟갈 씩 하루에 두 번 사료를 줍니다. 베티가 하루에 애완동물들에게 주는 사료가 몇 숟갈인지 보여주는 수식은 어느 것입니까?

A $(2 \times 3) \times 4$

B $(2 \times 3) + 4$

C $2 + (3 + 4)$

D $2 \times (3 + 4)$

계속

7

단위정육면체로 채워진 직사각 기둥의 도형이 아래에 나타나 있습니다. 각 단위정육면체의 변 길이는 1피트입니다.

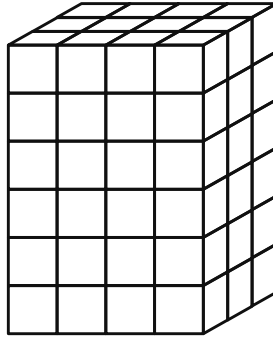

직사각 기둥의 부피는 몇 세제곱 피트입니까?

- A 12
- B 13
- C 54
- D 72

8

아래 수식을 계산한 값은?

$$[(3 \times 4) - 6] + 4 \times 2$$

- A 4
- B 14
- C 20
- D 30

9

리드 씨는 오일과 식초를 혼합하여 샐러드 드레싱을 만듭니다. 1회분 샐러드 드레싱을 만드는 데 오일 8 온스와 식초 3 온스를 혼합합니다. 리드 씨는 샐러드 드레싱 3 회분을 만듭니다. 리드 씨가 만드는 샐러드 드레싱은 총 몇 컵입니까?

- A $1\frac{3}{8}$ 컵
- B $2\frac{1}{16}$ 컵
- C $2\frac{3}{4}$ 컵
- D $4\frac{1}{8}$ 컵

10

아래 직사각형의 면적은 몇 제곱피트입니까?

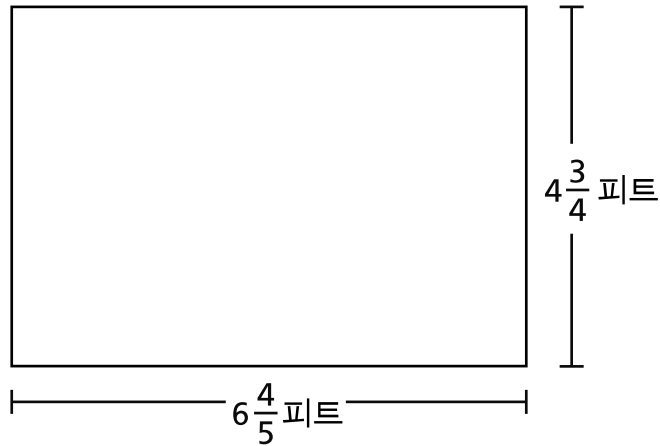

- A $11\frac{11}{20}$
- B $24\frac{12}{20}$
- C $27\frac{4}{20}$
- D $32\frac{6}{20}$

계속

11

에드는 토요일에 3킬로미터를 하이킹하고 일요일에 2킬로미터를 수영했습니다. 에드가 토요일과 일요일에 하이킹하고 수영한 거리는 총 몇 미터였습니까?

- A 50
- B 500
- C 5,000
- D 50,000

12

아래의 값을 구하는 데 사용할 수 있는 수식은?

$$1,284 \div 4$$

- A $(1,200 \div 4) \times (84 \div 4)$
- B $(1,200 \div 4) \div (84 \div 4)$
- C $(1,200 \div 4) + (84 \div 4)$
- D $(1,200 \div 4) - (84 \div 4)$

13

아래 그림의 직사각형 기둥의 부피를 구하는 데 사용할 수 **없는** 수식은?

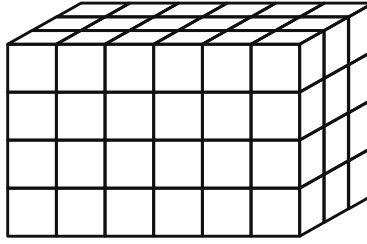

- A 12×6
- B 18×4
- C $6 \times 3 \times 4$
- D $6 \times 4 \times 6$

14

15.74를 가장 가까운 정수로 반올림 또는 반내림한 숫자는?

- A 10
- B 15
- C 16
- D 20

계속

15 잭은 매번 새 모이통을 채울 때 마다 $\frac{1}{3}$ 파운드의 새 모이가 듭니다. 잭이 4파운드의 새 모이가 있다면 새 모이통을 몇 번 채울 수 있습니까?

- A $1\frac{1}{3}$
- B $3\frac{2}{3}$
- C 11
- D 12

16 카를로스는 견과, 건포도, 시리얼을 사용하여 1파운드의 스낵믹스를 만듭니다. 아래 목록은 카를로스가 몇 파운드의 견과와 건포도를 사용하는지 보여줍니다.

- $\frac{1}{3}$ 파운드의 견과
- $\frac{2}{5}$ 파운드의 건포도

카를로스가 사용하는 시리얼은 몇 파운드입니까?

- A $\frac{3}{8}$
- B $\frac{5}{8}$
- C $\frac{4}{15}$
- D $\frac{11}{15}$

17 타라는 공원에서 $\frac{3}{4}$ 마일 떨어진 곳에서 삽니다. 니킬은 타라가 공원에서 떨어진 거리의 $6\frac{2}{3}$ 배 떨어진 곳에서 삽니다. 니킬의 집은 공원에서 얼마나 떨어진(마일) 거리입니까?

- A 2
- B 5
- C $5\frac{1}{6}$
- D $8\frac{8}{9}$

18 다음 중 $5 \times \frac{1}{2}$ 수식의 값을 설명하는 것은?

- A 그 값은 $\frac{1}{2}$ 보다 작습니다.
- B 그 값은 5보다 큼니다.
- C 그 값은 5와 6 사이입니다.
- D 그 값은 $\frac{1}{2}$ 과 5사이입니다.

계속

19 $\frac{1}{7} \div 5$ 수식의 값은?

A $\frac{1}{12}$

B $\frac{1}{35}$

C $\frac{5}{7}$

D $\frac{6}{7}$

20 콜은 16.02제곱미터 크기의 직사각형 정원 이 있습니다. 정원의 길이는 4.5미터입니다. 정원의 너비는 몇 미터입니까?

A 3.56

B 11.52

C 16.12

D 20.52

21 학교에서 새 책을 구입하기 위해 총 \$1,648을 모았습니다. 모여진 돈은 8개 반에 고루 나누어 줍니다. 각 반이 받을 금액은 얼마입니까?

A \$206

B \$207

C \$260

D \$270

아래의 선 작도는 샤이앤이 5일간 먹은 시리얼의 양을 나타냅니다.

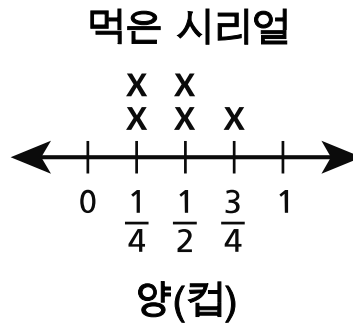

샤이앤이 5일간 먹은 시리얼은 총 몇 컵입니까?

- A $1\frac{1}{2}$
- B $1\frac{3}{4}$
- C $1\frac{4}{6}$
- D $2\frac{1}{4}$

23

라나는 도안에 나온 두 개의 블록을 사용하여 탑을 만들었습니다.

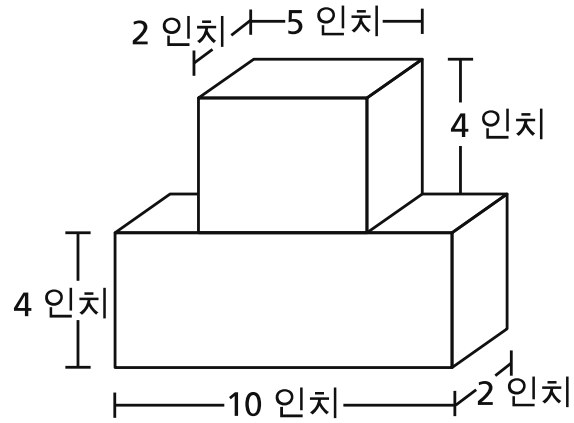

라나의 탑

라나가 만든 탑의 총 부피는 몇 세제곱 인치입니까?

- A 27
- B 80
- C 116
- D 120

5학년
수학 시험
세션 1
v202

Grade 5
Mathematics Test
Session 1
v202

THE STATE EDUCATION DEPARTMENT
THE UNIVERSITY OF THE STATE OF NEW YORK / ALBANY, NY 12234
2021 Mathematics Tests Map to the Standards
Grade 5 Released Questions

Question	Type	Key	Points	Standard	Cluster	Subscore	Secondary Standard(s)
Session 1							
1	Multiple Choice	D	1	CCSS.Math.Content.5.MD.C.5b	Measurement and Data	Measurement and Data	
2	Multiple Choice	D	1	CCSS.Math.Content.4.NF.C.5	Number and Operations - Fractions	Number and Operations - Fractions	
3	Multiple Choice	B	1	CCSS.Math.Content.5.NF.B.6	Number and Operations - Fractions	Number and Operations - Fractions	
4	Multiple Choice	C	1	CCSS.Math.Content.4.NF.C.6	Number and Operations in Base Ten	Number and Operations in Base Ten	
5	Multiple Choice	C	1	CCSS.Math.Content.5.NBT.A.3b	Number and Operations in Base Ten	Number and Operations in Base Ten	
6	Multiple Choice	D	1	CCSS.Math.Content.5.OA.A.2	Operations and Algebraic Thinking		
7	Multiple Choice	D	1	CCSS.Math.Content.5.MD.C.4	Measurement and Data	Measurement and Data	
8	Multiple Choice	B	1	CCSS.Math.Content.5.OA.A.1	Operations and Algebraic Thinking		
9	Multiple Choice	D	1	CCSS.Math.Content.5.MD.A.1	Measurement and Data	Measurement and Data	
10	Multiple Choice	D	1	CCSS.Math.Content.5.NF.B.4b	Number and Operations - Fractions	Number and Operations - Fractions	
11	Multiple Choice	C	1	CCSS.Math.Content.4.MD.A.2	Measurement and Data	Measurement and Data	
12	Multiple Choice	C	1	CCSS.Math.Content.5.NBT.B.6	Number and Operations in Base Ten	Number and Operations in Base Ten	
13	Multiple Choice	D	1	CCSS.Math.Content.5.MD.C.5a	Measurement and Data	Measurement and Data	
14	Multiple Choice	C	1	CCSS.Math.Content.5.NBT.A.4	Number and Operations in Base Ten	Number and Operations in Base Ten	
15	Multiple Choice	D	1	CCSS.Math.Content.5.NF.B.7c	Number and Operations - Fractions	Number and Operations - Fractions	
16	Multiple Choice	C	1	CCSS.Math.Content.5.NF.A.2	Number and Operations - Fractions	Number and Operations - Fractions	
17	Multiple Choice	B	1	CCSS.Math.Content.5.NF.B.6	Number and Operations - Fractions	Number and Operations - Fractions	
18	Multiple Choice	D	1	CCSS.Math.Content.5.NF.B.5a	Number and Operations - Fractions	Number and Operations - Fractions	
19	Multiple Choice	B	1	CCSS.Math.Content.5.NF.B.7a	Number and Operations - Fractions	Number and Operations - Fractions	
20	Multiple Choice	A	1	CCSS.Math.Content.5.NBT.B.7	Number and Operations in Base Ten	Number and Operations in Base Ten	
21	Multiple Choice	A	1	CCSS.Math.Content.5.NBT.B.6	Number and Operations in Base Ten	Number and Operations in Base Ten	
22	Multiple Choice	D	1	CCSS.Math.Content.5.MD.B.2	Measurement and Data	Measurement and Data	
23	Multiple Choice	D	1	CCSS.Math.Content.5.MD.C.5c	Measurement and Data	Measurement and Data	

This item map is intended to identify the primary analytic skills necessary to successfully answer each question. However, some questions measure proficiencies described in multiple standards, including a balanced combination of procedural and conceptual understanding.