



New York State
EDUCATION DEPARTMENT
Knowledge > Skill > Opportunity

New York State Testing Program
Grade 5
Mathematics Test

Released Questions

2024

New York State administered the Mathematics Tests in May 2024 and is making approximately 75% of the questions from these tests available for review and use.



New York State Testing Program

Grades 3–8 Mathematics

Released Questions from 2024 Exams

Background

As in past years, SED is releasing large portions of the 2024 NYS Grades 3–8 English Language Arts and Mathematics test materials for review, discussion, and use.

For 2024, included in these released materials are at least 75 percent of the test questions that appeared on the 2024 tests (including all constructed-response questions) that counted toward students' scores. Additionally, SED is also providing a map that details what each released question measures and the correct response to each question. These released materials will help students, families, educators, and the public better understand the tests and the New York State Education Department's expectations for students.

Understanding Math Questions

Multiple-Choice Questions

Multiple-choice questions are designed to assess the New York State P–12 Next Generation Learning Standards for Mathematics. Mathematics multiple-choice questions will be used mainly to assess standard algorithms and conceptual standards. Multiple-choice questions incorporate both the grade-level standards and the “Standards for Mathematical Practices.” Many questions are framed within the context of real-world applications or require students to complete multiple steps. Likewise, many of these questions are linked to more than one standard, drawing on the simultaneous application of multiple skills and concepts.

One-Credit Constructed-Response Questions

One-credit constructed-response questions require students to complete a task and provide only their final answer. These one-credit questions will often require multiple steps, assessing procedural skills, as well as conceptual understanding and application. While students may show how they arrived at their final answer, only the final answer will be scored.

Two-Credit Constructed-Response Questions

Two-credit constructed-response questions require students to complete tasks and show their work. These two-credit response questions will often require multiple steps, the application of multiple mathematics skills, and real-world applications. Many of the short-response questions will cover conceptual and application standards.

Three-Credit Constructed-Response Questions

Three-credit constructed-response questions ask students to show their work in completing two or more tasks or a more extensive problem. These three-credit response questions allow students to show their understanding of mathematical procedures, conceptual understanding, and application. Three-credit response questions may also assess student reasoning and the ability to critique the arguments of others. The scoring rubric for all constructed-response questions can be found in the grade-level Educator Guides at <https://www.nysed.gov/state-assessment/grades-3-8-ela-and-math-test-manuals>.

New York State P–12 Next Generation Learning Standards Alignment

The alignment(s) to the New York State P–12 Next Generation Learning Standards for Mathematics is/are intended to identify the primary analytic skills necessary to successfully answer each question. However, some questions measure proficiencies described in multiple standards, including a balanced combination of procedure and conceptual understanding. For example, two-credit and three-credit constructed-response questions require students to show an understanding of mathematical procedures, concepts, and applications.

These Released Questions Do Not Comprise a “Mini Test”

To ensure it is possible to develop future tests, some content must remain secure. This document is *not* intended to be representative of the entire test, to show how operational tests look, or to provide information about how teachers should administer the test; rather, its purpose is to provide an overview of how the test reflects the demands of the New York State P–12 Next Generation Learning Standards.

The released questions do not represent the full spectrum of the standards assessed on the State tests, nor do they represent the full spectrum of how the standards should be taught and assessed in the classroom. It should not be assumed that a particular standard will be measured by an identical question in future assessments.

Name: _____



New York State Testing Program

Mathematics Test Session 1

Grade 5

Spring 2024

RELEASED QUESTIONS

Developed and published under contract with the New York State Education Department by NWEA, a division of HMH, 14720 Energy Way, Apple Valley, MN 55124. Copyright © 2024 by the New York State Education Department.

Session 1

Session 1



TIPS FOR TAKING THE TEST

Here are some ideas to help you do your best:

- Read each question carefully. Take your time.
- You have a ruler, a protractor, and a reference sheet that you can use on the test if they help you answer the question.

1 Carlos walks 3.65 kilometers on Saturday and 1.46 kilometers on Sunday. How many total kilometers does Carlos walk on Saturday and Sunday?

- A 2.19
- B 2.29
- C 5.01
- D 5.11

2 Which expression is equivalent to $5 \times \frac{3}{4}$?

- A $\frac{5}{1} + \frac{3}{4}$
- B $\frac{5}{1} - \frac{3}{4}$
- C $\frac{3}{4} + \frac{3}{4} + \frac{3}{4} + \frac{3}{4} + \frac{3}{4}$
- D $\frac{3}{4} \times \frac{3}{4} \times \frac{3}{4} \times \frac{3}{4} \times \frac{3}{4}$

GO ON

3

A diagram of a right rectangular prism made of unit cubes is shown below.

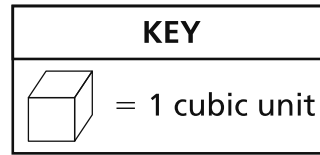
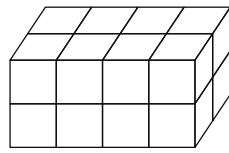

What measurement for the right rectangular prism is equal to the total number of cubes?

- A area
- B height
- C perimeter
- D volume

4

What is 34.275 rounded to the nearest hundredth?

- A 34.0
- B 34.3
- C 34.27
- D 34.28

7

A group of 4 gold miners found 10 ounces of gold. The miners shared the gold equally. How much gold, in ounces, did each miner receive?

A $\frac{1}{4}$

B $\frac{4}{10}$

C $2\frac{2}{10}$

D $2\frac{1}{2}$

GO ON

9

A diagram of a 3-dimensional figure is shown below.

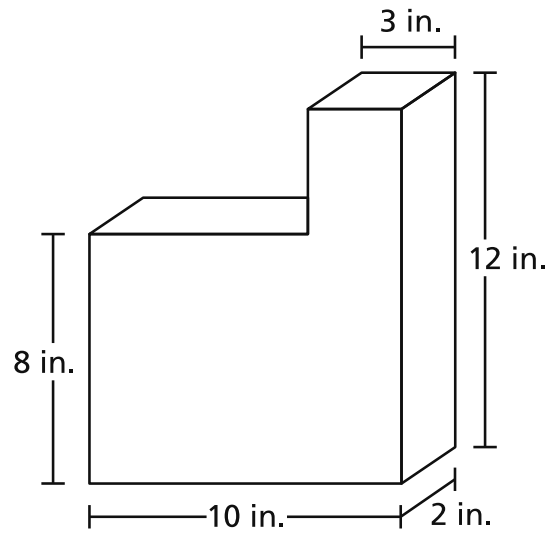

What is the volume, in cubic inches, of the figure?

- A 35
- B 72
- C 184
- D 240

10

Steven has 3 cups of raisins. He shares all the raisins equally among himself and his friends.

If each person gets $\frac{1}{4}$ cup of raisins, how many people, in total, get raisins?

- A 1
- B 4
- C 7
- D 12

GO ON

12 Saul has \$6.00 in quarters. He uses all of the quarters to play video games. If each game requires 3 quarters, what is the total number of video games that Saul plays?

- A 2
- B 8
- C 12
- D 18

15 A company has an annual employee picnic. The company rents buses to transport the employees to the picnic area. There are 1,320 employees. Each bus carries a total of 54 employees. What is the **minimum** number of buses the company needs to transport all of the employees to the picnic area?

- A 24
- B 25
- C 26
- D 27

16 Which comparison is true?

- A $0.04 > 0.14$
- B $0.83 > 0.92$
- C $0.27 < 0.36$
- D $0.52 < 0.49$

19

Which statement about the relationship between parallelograms and rectangles is true?

- A All parallelograms are rectangles, but not all rectangles are parallelograms.
- B All rectangles are parallelograms, but not all parallelograms are rectangles.
- C All rectangles are parallelograms, and all parallelograms are rectangles.
- D Not all parallelograms are rectangles, and not all rectangles are parallelograms.

GO ON

27 What is the value of the expression $\frac{1}{7} \div 5$?

A $\frac{1}{35}$

B $\frac{1}{12}$

C $\frac{5}{7}$

D $\frac{6}{7}$

28 Marcel has $2\frac{1}{3}$ cups of milk. He uses $\frac{2}{3}$ cup for his cereal and $1\frac{1}{4}$ cups for a pancake recipe. How much milk, in cups, does Marcel have remaining?

A $\frac{5}{12}$

B $\frac{7}{12}$

C $1\frac{1}{12}$

D $1\frac{11}{12}$

GO ON

30 What is the area, in square units, of a rectangle with side lengths $3\frac{3}{4}$ units and $9\frac{1}{2}$ units?

A $13\frac{1}{4}$

B $27\frac{3}{8}$

C $35\frac{5}{8}$

D $47\frac{1}{2}$

STOP

**Grade 5
Mathematics Test
Session 1
Spring 2024**

Name: _____



New York State Testing Program

Mathematics Test Session 2

Grade 5

Spring 2024

RELEASED QUESTIONS

Developed and published under contract with the New York State Education Department by NWEA, a division of HMH, 14720 Energy Way, Apple Valley, MN 55124. Copyright © 2024 by the New York State Education Department.

Session 2



TIPS FOR TAKING THE TEST

Here are some ideas to help you do your best:

- Read each question carefully. Take your time.
- You have a ruler, a protractor, and a reference sheet that you can use on the test if they help you answer the question.
- Be sure to show your work when asked.
- Be sure to explain your answer when asked.

31 Rida is walking on a trail that is 2.5 kilometers long. She has walked 0.72 kilometer of the trail so far. How many more kilometers does Rida still need to walk to complete the trail?

- A 0.53
- B 0.97
- C 1.78
- D 3.22

32 What is the value of the expression shown below?

$$\frac{1}{2} + \frac{2}{3} - \frac{1}{4}$$

- A $\frac{2}{1}$
- B $\frac{4}{9}$
- C $\frac{11}{12}$
- D $\frac{17}{12}$

33 Lisa drew a four-sided shape that had exactly one pair of parallel lines and two right angles. Which list correctly classifies the shape Lisa drew?

- A square, rhombus, quadrilateral
- B trapezoid, quadrilateral, polygon
- C rectangle, parallelogram, polygon
- D rhombus, parallelogram, quadrilateral

GO ON

34 Elsie has two equal-sized bags of rice. One bag is $\frac{1}{3}$ full, and the other bag is $\frac{1}{5}$ full. She combines the rice into one of the bags. What fraction of a full bag of rice does Elsie now have after combining the rice?

A $\frac{1}{2}$

B $\frac{1}{4}$

C $\frac{2}{15}$

D $\frac{8}{15}$

35 The distance between two houses on a street is 450 meters. What is the distance measured in kilometers?

A 45

B 4.5

C 0.45

D 0.045

36

This question is worth 1 credit.

Calvin has a box in the shape of a right rectangular prism. He packs it with unit cubes to determine its volume. The dimensions of the box are listed below.

- length: 16 inches
- width: 7 inches
- height: 8 inches

Each unit cube is 1 cubic inch. How many unit cubes will Calvin need to completely fill the box?

Answer _____ unit cubes

GO ON

37

This question is worth 1 credit.

A family takes a cake to a party. When the family is ready to leave the party, $\frac{3}{4}$ of the cake is left. The family leaves $\frac{1}{2}$ of the leftover cake at the party and takes the remaining cake home. What fraction of all of the cake does the family take home?

Answer _____ of the cake

GO ON

38

This question is worth 1 credit.

A teacher has 55 sheets of stickers with a total of 1,320 stickers. Each sheet has the same number of stickers. How many stickers are on each sheet?

Answer _____ stickers

GO ON

39

This question is worth 2 credits.

Students in a fifth-grade math class measured the lengths of 12 erasers. The line plot below shows the results.

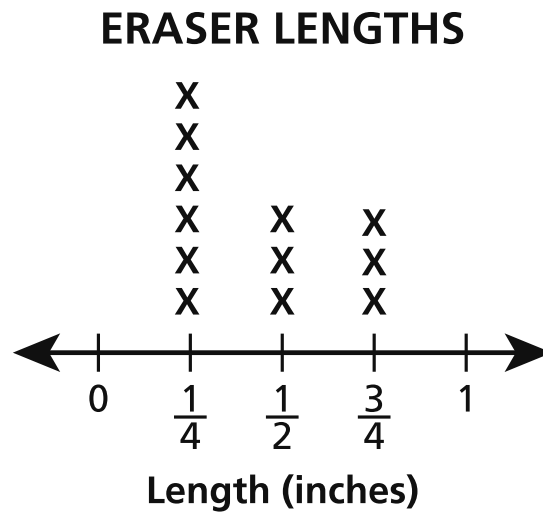

What is the total length, in inches, of all the erasers when they are lined up end to end?

Show your work.

Answer _____ inches

GO ON

40 This question is worth 2 credits.

A table top is completely covered with square tiles as shown below. Each square tile has a side length of $\frac{1}{2}$ foot.

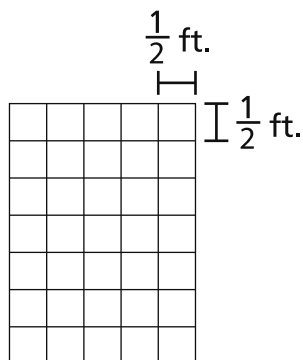

What is the area, in square feet, of the table top?

Show your work.

Answer _____ square feet

GO ON

41

This question is worth 2 credits.

Rosa and Steve each have a baseball card collection. Steve has $\frac{1}{8}$ as many baseball cards in his collection as Rosa. Who has more baseball cards? Be sure to include what you know about fractions in your answer.

Explain your answer.

42

This question is worth 2 credits.

A student incorrectly wrote the number three hundred sixty-two and four hundred eight thousandths in expanded form as shown below.

$$(3 \times 100) + (6 \times 10) + (2 \times 1) + \left(4 \times \frac{1}{10}\right) + \left(8 \times \frac{1}{100}\right)$$

What error did the student make when writing the number in expanded form?
Be sure to include the correct number in standard form in your answer.

Explain your answer.

GO ON

43

This question is worth 2 credits.

The base of the right rectangular prism shown below is filled with unit cubes.

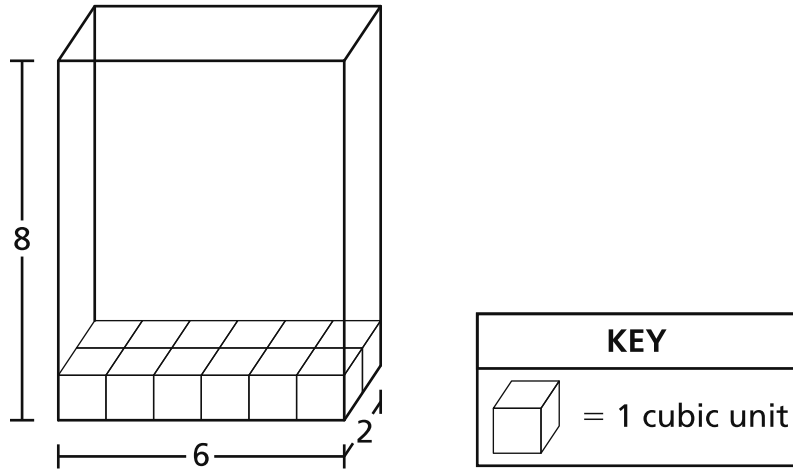

How many more unit cubes are needed to completely fill the right rectangular prism?

Explain how you determined your answer.

44

This question is worth 3 credits.

Liam makes and sells handmade blankets. He buys 18 yards of fabric at a rate of \$6.75 per yard. Liam uses 1.5 yards of fabric to make each blanket, and uses all of the fabric. Liam sells each blanket for \$18.75. What is the profit Liam makes after buying the fabric and selling all the blankets?

Show your work.

Answer \$ _____

STOP

**Grade 5
Mathematics Test
Session 2
Spring 2024**

THE STATE EDUCATION DEPARTMENT
THE UNIVERSITY OF THE STATE OF NEW YORK / ALBANY, NY 12234
2024 Mathematics Tests Map to the Standards
Grade 5

Question	Type	Key	Points	Standard	Cluster	Subscore	Secondary Standard(s)
Session 1							
1	Multiple Choice	D	1	NGLS.Math.Content.NY-5.NBT.7	Number and Operations in Base Ten	Number and Operations in Base Ten	
2	Multiple Choice	C	1	NGLS.Math.Content.NY-5.NF.4a	Number and Operations - Fractions	Number and Operations - Fractions	
3	Multiple Choice	D	1	NGLS.Math.Content.NY-5.MD.3a	Measurement and Data	Measurement and Data	
4	Multiple Choice	D	1	NGLS.Math.Content.NY-5.NBT.4	Number and Operations in Base Ten	Number and Operations in Base Ten	
7	Multiple Choice	D	1	NGLS.Math.Content.NY-5.NF.3	Number and Operations - Fractions	Number and Operations - Fractions	
9	Multiple Choice	C	1	NGLS.Math.Content.NY-5.MD.5c	Measurement and Data	Measurement and Data	
10	Multiple Choice	D	1	NGLS.Math.Content.NY-5.NF.7c	Number and Operations - Fractions	Number and Operations - Fractions	
12	Multiple Choice	B	1	NGLS.Math.Content.NY-4.MD.2a	Measurement and Data	Measurement and Data	
15	Multiple Choice	B	1	NGLS.Math.Content.NY-5.NBT.6	Number and Operations in Base Ten	Number and Operations in Base Ten	
16	Multiple Choice	C	1	NGLS.Math.Content.NY-5.NBT.3b	Number and Operations in Base Ten	Number and Operations in Base Ten	
19	Multiple Choice	B	1	NGLS.Math.Content.NY-5.G.3	Geometry		
27	Multiple Choice	A	1	NGLS.Math.Content.NY-5.NF.7a	Number and Operations - Fractions	Number and Operations - Fractions	
28	Multiple Choice	A	1	NGLS.Math.Content.NY-5.NF.2	Number and Operations - Fractions	Number and Operations - Fractions	
30	Multiple Choice	C	1	NGLS.Math.Content.NY-5.NF.4b	Number and Operations - Fractions	Number and Operations - Fractions	
Session 2							
31	Multiple Choice	C	1	NGLS.Math.Content.NY-5.NBT.7	Number and Operations in Base Ten	Number and Operations in Base Ten	
32	Multiple Choice	C	1	NGLS.Math.Content.NY-5.NF.1	Number and Operations - Fractions	Number and Operations - Fractions	
33	Multiple Choice	B	1	NGLS.Math.Content.NY-5.G.4	Geometry		
34	Multiple Choice	D	1	NGLS.Math.Content.NY-5.NF.2	Number and Operations - Fractions	Number and Operations - Fractions	
35	Multiple Choice	C	1	NGLS.Math.Content.NY-5.MD.1	Measurement and Data	Measurement and Data	
36	Constructed Response	n/a	1	NGLS.Math.Content.NY-5.MD.5a	Measurement and Data	Measurement and Data	
37	Constructed Response	n/a	1	NGLS.Math.Content.NY-5.NF.6	Number and Operations - Fractions	Number and Operations - Fractions	
38	Constructed Response	n/a	1	NGLS.Math.Content.NY-5.NBT.6	Number and Operations in Base Ten	Number and Operations in Base Ten	
39	Constructed Response	n/a	2	NGLS.Math.Content.NY-5.MD.2	Measurement and Data	Measurement and Data	
40	Constructed Response	n/a	2	NGLS.Math.Content.NY-5.NF.4b	Number and Operations - Fractions	Number and Operations - Fractions	
41	Constructed Response	n/a	2	NGLS.Math.Content.NY-5.NF.5a	Number and Operations - Fractions	Number and Operations - Fractions	
42	Constructed Response	n/a	2	NGLS.Math.Content.NY-5.NBT.3a	Number and Operations in Base Ten	Number and Operations in Base Ten	
43	Constructed Response	n/a	2	NGLS.Math.Content.NY-5.MD.5a	Measurement and Data	Measurement and Data	
44	Constructed Response	n/a	3	NGLS.Math.Content.NY-5.NBT.7	Number and Operations in Base Ten	Number and Operations in Base Ten	

*This item map is intended to identify the primary analytic skills necessary to successfully answer each question. However, some questions measure proficiencies described in multiple standards, including a balanced combination of procedural and conceptual understanding.