

**GEOMETRY**

Friday, June 21, 2024 — 9:15 a.m. to 12:15 p.m., only

Student Name: \_\_\_\_\_

School Name: \_\_\_\_\_

**The possession or use of any communications device is strictly prohibited when taking this examination. If you have or use any communications device, no matter how briefly, your examination will be invalidated and no score will be calculated for you.**

Print your name and the name of your school on the lines above.

A separate answer sheet for **Part I** has been provided to you. Follow the instructions from the proctor for completing the student information on your answer sheet.

This examination has four parts, with a total of 35 questions. You must answer all questions in this examination. Record your answers to the Part I multiple-choice questions on the separate answer sheet. Write your answers to the questions in **Parts II, III, and IV** directly in this booklet. All work should be written in pen, except graphs and drawings, which should be done in pencil. Clearly indicate the necessary steps, including appropriate formula substitutions, diagrams, graphs, charts, etc. Utilize the information provided for each question to determine your answer. Note that diagrams are not necessarily drawn to scale.

The formulas that you may need to answer some questions in this examination are found at the end of the examination. This sheet is perforated so you may remove it from this booklet.

Scrap paper is not permitted for any part of this examination, but you may use the blank spaces in this booklet as scrap paper. A perforated sheet of scrap graph paper is provided at the end of this booklet for any question for which graphing may be helpful but is not required. You may remove this sheet from this booklet. Any work done on this sheet of scrap graph paper will *not* be scored.

When you have completed the examination, you must sign the statement printed at the end of the answer sheet, indicating that you had no unlawful knowledge of the questions or answers prior to the examination and that you have neither given nor received assistance in answering any of the questions during the examination. Your answer sheet cannot be accepted if you fail to sign this declaration.

**Notice ...**

**A graphing calculator, a straightedge (ruler), and a compass must be available for you to use while taking this examination.**

**DO NOT OPEN THIS EXAMINATION BOOKLET UNTIL THE SIGNAL IS GIVEN.**

## Part I

Answer all 24 questions in this part. Each correct answer will receive 2 credits. No partial credit will be allowed. Utilize the information provided for each question to determine your answer. Note that diagrams are not necessarily drawn to scale. For each statement or question, choose the word or expression that, of those given, best completes the statement or answers the question. Record your answers on your separate answer sheet. [48]

Use this space for  
computations.

- 1 In the diagram below,  $\triangle BRI$  is the image of  $\triangle JOE$  after a translation. Triangle  $CAT$  is the image of  $\triangle BRI$  after a line reflection.

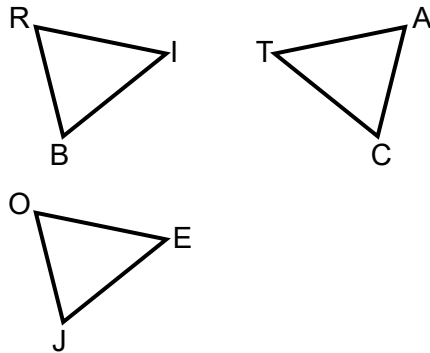

Which statement is always true?

- (1)  $\angle R \cong \angle T$                       (3)  $\overline{JE} \cong \overline{RI}$   
(2)  $\angle J \cong \angle A$                       (4)  $\overline{OE} \cong \overline{AT}$
- 2 A right cylinder is cut parallel to its base. The shape of this cross section is a
- (1) cone                                      (3) triangle  
(2) circle                                    (4) rectangle
- 3 What is the minimum number of degrees that a regular hexagon must rotate about its center to carry it onto itself?
- (1)  $45^\circ$                                       (3)  $60^\circ$   
(2)  $72^\circ$                                       (4)  $120^\circ$

**Use this space for  
computations.**

- 4 In the diagram below, a sphere is inscribed inside a cube. The cube has edge lengths of 18.

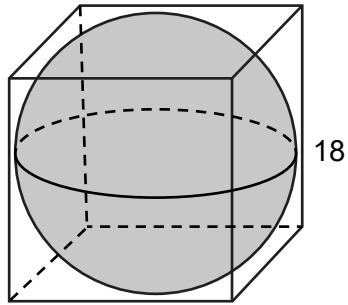

What is the volume of the sphere, in terms of  $\pi$ ?

- (1)  $108\pi$  (3)  $972\pi$   
(2)  $432\pi$  (4)  $7776\pi$
- 5 In the diagram below,  $\overline{EM}$  intersects  $\overline{HA}$  at  $J$ ,  $\overline{EA} \perp \overline{HA}$ , and  $\overline{EM} \perp \overline{HM}$ .

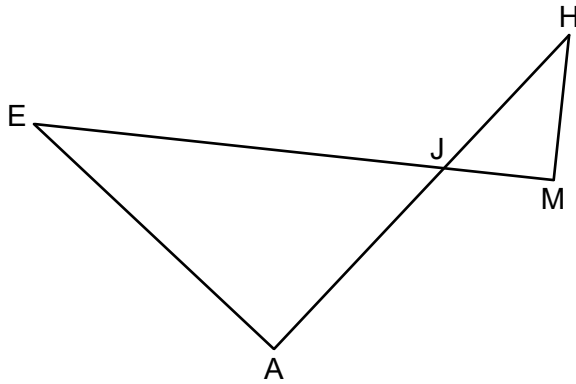

If  $EA = 7.2$ ,  $EJ = 9$ ,  $AJ = 5.4$ , and  $HM = 3.29$ , what is the length of  $\overline{MJ}$ , to the nearest hundredth?

- (1) 2.47 (3) 4.11  
(2) 2.63 (4) 4.39

Use this space for  
computations.

6 Which equation represents the line that passes through the point  $(2, -7)$  and is perpendicular to the line whose equation is  $y = \frac{3}{4}x + 4$ ?

(1)  $y + 7 = \frac{3}{4}(x - 2)$                       (3)  $y + 7 = -\frac{4}{3}(x - 2)$

(2)  $y - 7 = \frac{3}{4}(x + 2)$                       (4)  $y - 7 = -\frac{4}{3}(x + 2)$

7 In  $\triangle RHM$  below,  $m\angle R = 110^\circ$  and  $m\angle M = 40^\circ$ .

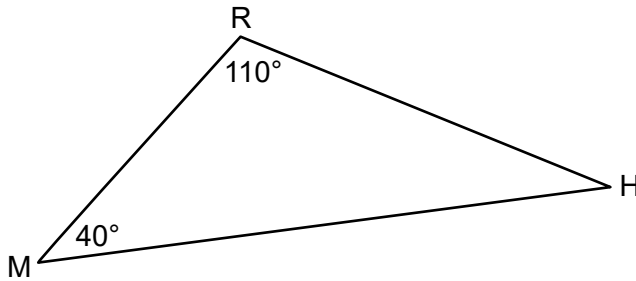

If  $\triangle RHM$  is reflected over side  $\overline{HM}$  to form quadrilateral  $RHR'M$ , which statement is always true?

- (1) Quadrilateral  $RHR'M$  is a parallelogram.
- (2)  $m\angle MHR' = 40^\circ$
- (3)  $m\angle HMR' = 40^\circ$
- (4)  $\overline{MR} \cong \overline{HR'}$

Use this space for computations.

- 8 The funnel shown below can be used to decorate cookies with melted chocolate. The funnel can be modeled by a cone whose radius is 6 cm and height is 13 cm.

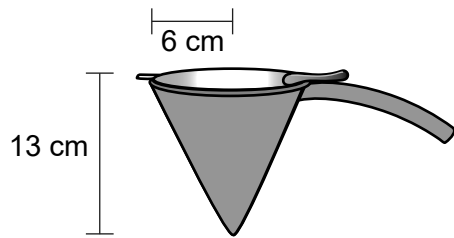

The baker uses 2 cubic centimeters of chocolate to decorate each cookie. When the funnel is completely filled, what is the maximum number of cookies that can be decorated with the melted chocolate?

- (1) 78                                      (3) 490  
(2) 245                                      (4) 735
- 9 In circle  $O$  below, chords  $\overline{CT}$  and  $\overline{BN}$  intersect at point  $A$ . Chords  $\overline{CB}$  and  $\overline{NT}$  are drawn.

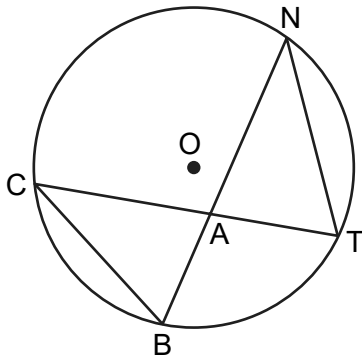

Which statement is always true?

- (1)  $\frac{NT}{TA} = \frac{CB}{BA}$                                       (3)  $\frac{NA}{AB} = \frac{TA}{AC}$   
(2)  $\angle BAC \cong \angle ATN$                                       (4)  $\angle BCA \cong \angle NTA$

Use this space for computations.

- 10 In the diagram below of  $\triangle ABC$ ,  $\overline{CBF}$  is drawn,  $\overline{AB}$  bisects  $\angle FBD$ , and  $\overline{BD} \perp \overline{AC}$ .

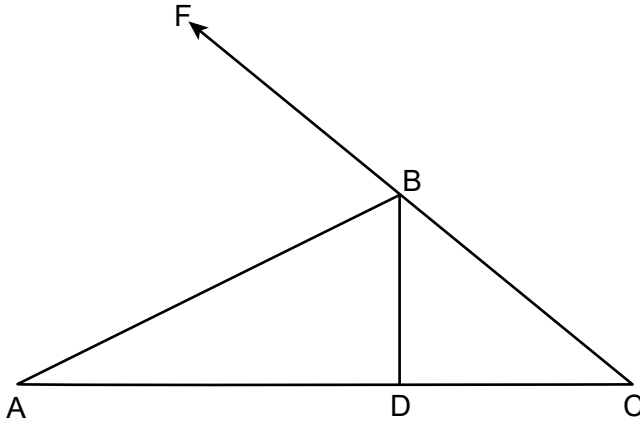

If  $m\angle C = 42^\circ$ , what is  $m\angle A$ ?

- (1)  $24^\circ$                                       (3)  $48^\circ$   
(2)  $33^\circ$                                       (4)  $66^\circ$
- 11 In circle  $O$  below,  $OA = 6$ , and  $m\angle COA = 100^\circ$ .

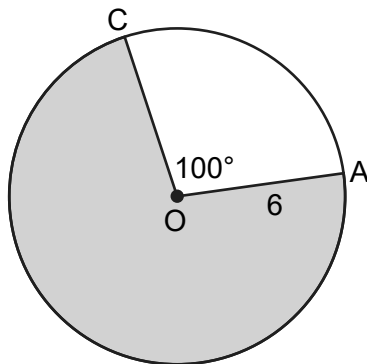

What is the area of the shaded sector?

- (1)  $10\pi$                                       (3)  $\frac{10\pi}{3}$   
(2)  $26\pi$                                       (4)  $\frac{26\pi}{3}$

**Use this space for  
computations.**

**12** In rectangle  $ABCD$ , diagonal  $\overline{AC}$  is drawn. The measure of  $\angle ACD$  is  $37^\circ$  and the length of  $\overline{BC}$  is 7.6 cm. What is the length of  $\overline{AC}$ , to the nearest tenth of a centimeter?

- (1) 4.6    (3) 10.1  
(2) 9.5    (4) 12.6

**13** A peanut butter manufacturer would like to use a cylindrical jar with a volume of  $1180 \text{ cm}^3$ . The jar has a height of 10 cm. What is the diameter of the jar, to the nearest tenth of a centimeter?

- (1) 3.8    (3) 10.9  
(2) 6.1    (4) 12.3

**14** Triangle  $KLM$  is dilated by a scale factor of 3 to map onto triangle  $DRS$ . Which statement is *not* always true?

- (1)  $\angle K \cong \angle D$   
(2)  $KM = \frac{1}{3}DS$   
(3) The area of  $\triangle DRS$  is 3 times the area of  $\triangle KLM$ .  
(4) The perimeter of  $\triangle DRS$  is 3 times the perimeter of  $\triangle KLM$ .

**Use this space for  
computations.**

**15** A rectangle with dimensions of 4 feet by 7 feet is continuously rotated about one of its 4-foot sides. The resulting three-dimensional object is a

- (1) cylinder with a height of 7 feet and a base radius of 4 feet.
- (2) cylinder with a height of 4 feet and a base radius of 7 feet.
- (3) cone with a height of 7 feet and a base radius of 7 feet.
- (4) cone with a height of 4 feet and a base radius of 7 feet.

**16** In right triangle  $ABC$ , altitude  $\overline{CD}$  is drawn to hypotenuse  $\overline{AB}$ . If  $AD = 4$  and  $CD = 8$ , the length of  $\overline{BD}$  is

- (1)  $\sqrt{48}$
- (2)  $\sqrt{80}$
- (3) 12
- (4) 16

**17** If  $ABCD$  is a parallelogram, which additional information is sufficient to prove that  $ABCD$  is a rectangle?

- (1)  $\overline{AB} \cong \overline{BC}$
- (2)  $\overline{AB} \parallel \overline{CD}$
- (3)  $\overline{AC} \cong \overline{BD}$
- (4)  $\overline{AC} \perp \overline{BD}$



Use this space for computations.

18 Line segment  $APB$  has endpoints  $A(-5,4)$  and  $B(7,-4)$ . What are the coordinates of  $P$  if  $AP:PB$  is in the ratio  $1:3$ ?

- (1)  $(-2,2)$
- (2)  $(-1,1.3)$
- (3)  $(1,0)$
- (4)  $(4,-2)$

19 In the diagram below,  $\overline{AB}$  and  $\overline{CD}$  intersect at  $E$ , and  $\overline{CA}$  and  $\overline{DB}$  are drawn.

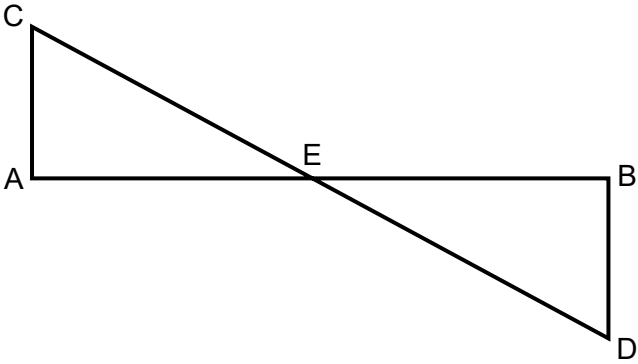

If  $\overline{CA} \parallel \overline{DB}$ , which statement is always true?

- (1)  $\overline{AE} \cong \overline{BE}$
- (2)  $\overline{CA} \cong \overline{DB}$
- (3)  $\triangle AEC \sim \triangle BED$
- (4)  $\triangle AEC \cong \triangle BED$

Use this space for computations.

**20** If  $\sin(3x + 9)^\circ = \cos(5x - 7)^\circ$ , what is the value of  $x$ ?

- (1) 8    (3) 33  
(2) 11                                         (4) 42

**21** Which set of integers could represent the lengths of the sides of an isosceles triangle?

- (1) {1, 1, 3}                                (3) {3, 3, 6}  
(2) {2, 2, 5}                                (4) {4, 4, 7}

**22** In the diagram shown below, altitude  $\overline{CD}$  is drawn to the hypotenuse of right triangle  $ABC$ .

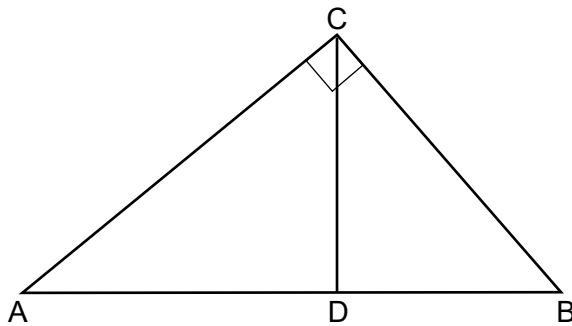

Which equation can always be used to find the length of  $\overline{AC}$ ?

- (1)  $\frac{AC}{CD} = \frac{CD}{AD}$                                 (3)  $\frac{AC}{CD} = \frac{CD}{BC}$   
(2)  $\frac{CD}{AC} = \frac{AC}{AB}$                                 (4)  $\frac{AB}{AC} = \frac{AC}{AD}$

**Use this space for  
computations.**

**23** Which congruence statement is sufficient to prove parallelogram *MARK* is a rhombus?

(1)  $\overline{MA} \cong \overline{MK}$

(3)  $\angle K \cong \angle A$

(2)  $\overline{MA} \cong \overline{KR}$

(4)  $\angle R \cong \angle A$

**24** A line whose equation is  $y = -2x + 3$  is dilated by a scale factor of 4 centered at  $(0,3)$ . Which equation represents the image of the line after the dilation?

(1)  $y = -2x + 3$

(3)  $y = -8x + 3$

(2)  $y = -2x + 12$

(4)  $y = -8x + 12$

---

## Part II

Answer all 7 questions in this part. Each correct answer will receive 2 credits. Clearly indicate the necessary steps, including appropriate formula substitutions, diagrams, graphs, charts, etc. Utilize the information provided for each question to determine your answer. Note that diagrams are not necessarily drawn to scale. For all questions in this part, a correct numerical answer with no work shown will receive only 1 credit. All answers should be written in pen, except for graphs and drawings, which should be done in pencil. [14]

25 In  $\triangle ABC$  below,  $m\angle C = 90^\circ$ ,  $AC = 11$ , and  $AB = 18$ .

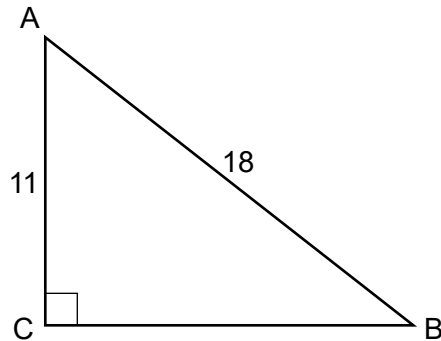

Determine and state the measure of angle A, to the *nearest degree*.

**26** Use a compass and straightedge to construct an equilateral triangle inscribed in circle A below.  
[Leave all construction marks.]

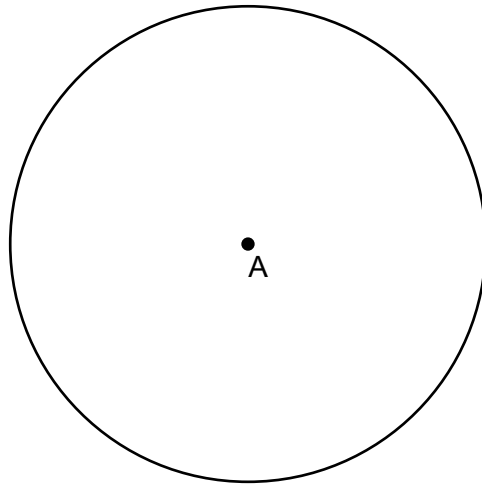

27 Quadrilateral  $DEAR$  and its image, quadrilateral  $D'E'A'R'$ , are graphed on the set of axes below.

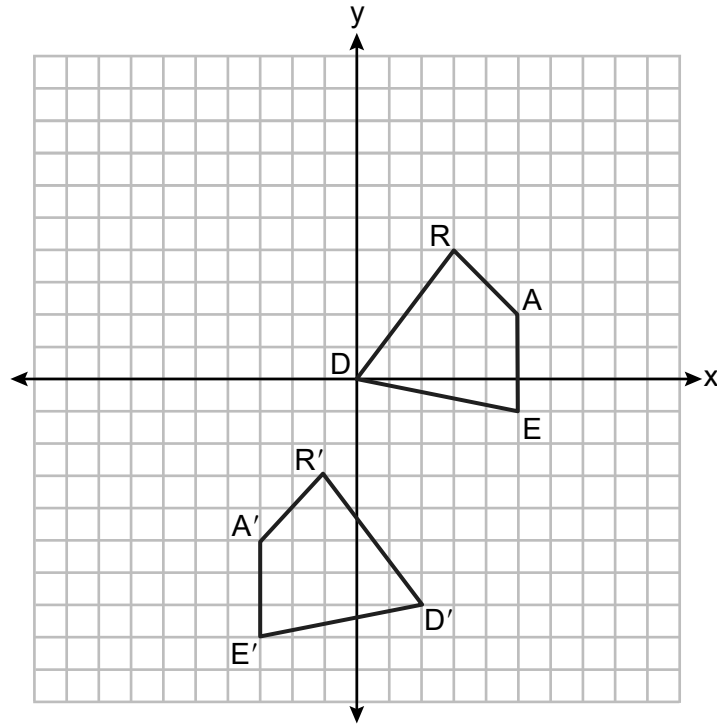

Describe a sequence of transformations that maps quadrilateral  $DEAR$  onto quadrilateral  $D'E'A'R'$ .

28 In circle  $P$  below, tangent  $\overline{AL}$  and secant  $\overline{AKE}$  are drawn.

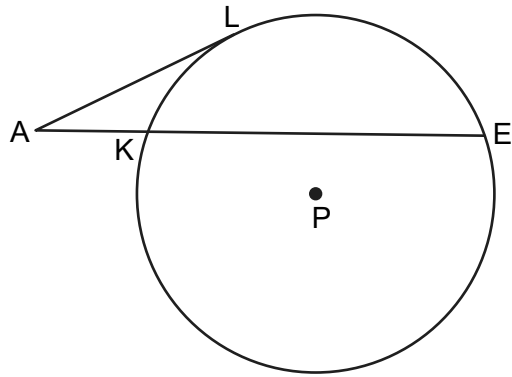

If  $AK = 12$  and  $KE = 36$ , determine and state the length of  $\overline{AL}$ .

**29** The equation of a circle is  $x^2 + y^2 + 8x - 6y + 7 = 0$ . Determine and state the coordinates of the center and the length of the radius of the circle.



30 On the set of axes below,  $\triangle ABC$  is drawn with vertices that have coordinates  $A(2, -3)$ ,  $B(4, 5)$ , and  $C(-5, 1)$ .

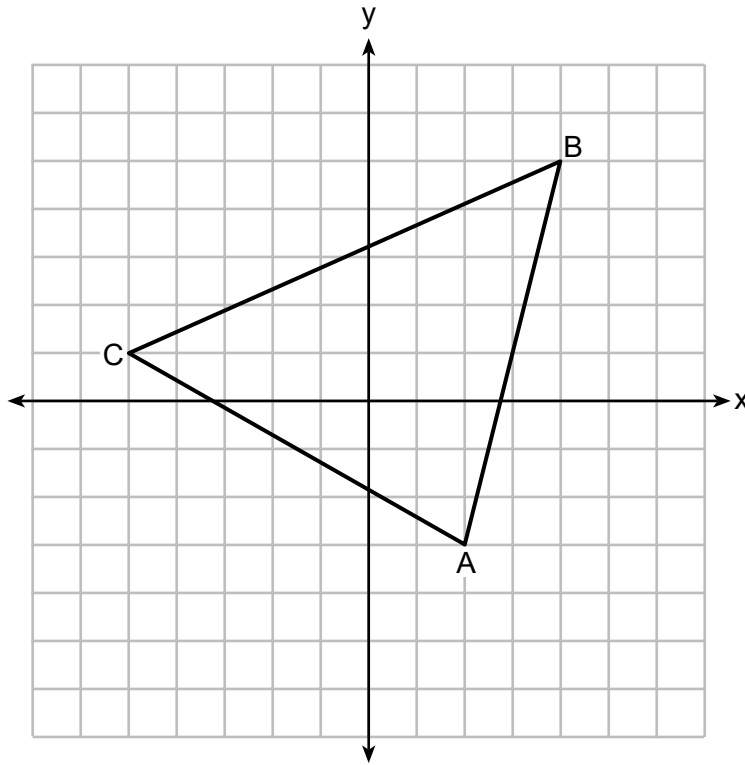

Determine and state the area of  $\triangle ABC$ .

31 In the diagram below,  $AE = 15$ ,  $EB = 27$ ,  $AF = 20$ , and  $FC = 36$ .

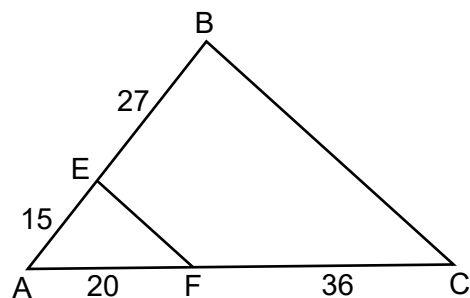

Explain why  $\overline{EF} \parallel \overline{BC}$ .

### Part III

Answer all 3 questions in this part. Each correct answer will receive 4 credits. Clearly indicate the necessary steps, including appropriate formula substitutions, diagrams, graphs, charts, etc. Utilize the information provided for each question to determine your answer. Note that diagrams are not necessarily drawn to scale. For all questions in this part, a correct numerical answer with no work shown will receive only 1 credit. All answers should be written in pen, except for graphs and drawings, which should be done in pencil. [12]

- 32 A building is composed of a rectangular pyramid on top of a rectangular prism, as shown in the diagram below. The rectangular prism has a length of 38 feet, a width of 15 feet, and a height of 22 feet. The rectangular pyramid sits directly on top of the rectangular prism, and its height is 12 feet.

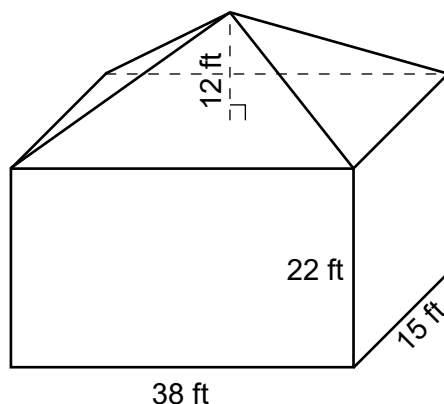

An air purification filter was installed that will clean all the air in the building at a rate of 2400 cubic feet per minute. Determine and state how long it will take, to the *nearest tenth of a minute*, for the filter to clean the air contained in the building.

33 Given:  $\triangle ABC$ ,  $\triangle DEF$ ,  $\overline{AB} \perp \overline{BC}$ ,  $\overline{DE} \perp \overline{EF}$ ,  $\overline{AE} \cong \overline{DB}$ , and  $\overline{AC} \parallel \overline{FD}$

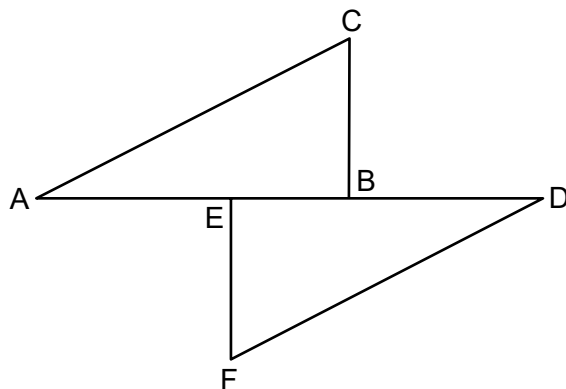

Prove:  $\triangle ABC \cong \triangle DEF$

- 34 In the diagram below, a boat at point  $A$  is traveling toward the most powerful waterfall in North America, the Horseshoe Falls. The Horseshoe Falls has a vertical drop of 188 feet. The angle of elevation from point  $A$  to the top of the waterfall is  $15^\circ$ .

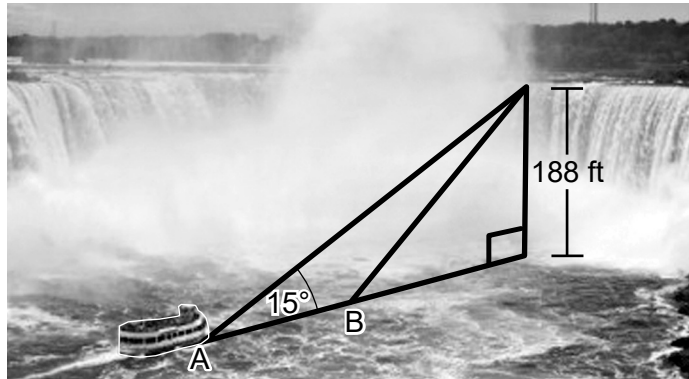

After the boat travels toward the falls, the angle of elevation at point  $B$  to the top of the waterfall is  $23^\circ$ . Determine and state, to the *nearest foot*, the distance the boat traveled from point  $A$  to point  $B$ .

**Part IV**

**Answer the question in this part. A correct answer will receive 6 credits. Clearly indicate the necessary steps, including appropriate formula substitutions, diagrams, graphs, charts, etc. Utilize the information provided to determine your answer. Note that diagrams are not necessarily drawn to scale. A correct numerical answer with no work shown will receive only 1 credit. All answers should be written in pen, except for graphs and drawings, which should be done in pencil. [6]**

**35** Triangle  $JOE$  has vertices whose coordinates are  $J(4,6)$ ,  $O(-2,4)$ , and  $E(6,0)$ .

Prove that  $\triangle JOE$  is isosceles.

[The use of the set of axes on the next page is optional.]

**Question 35 is continued on the next page.**

**Question 35 continued**

Point  $Y(2,2)$  is on  $\overline{OE}$ .

Prove that  $\overline{JY}$  is the perpendicular bisector of  $\overline{OE}$ .

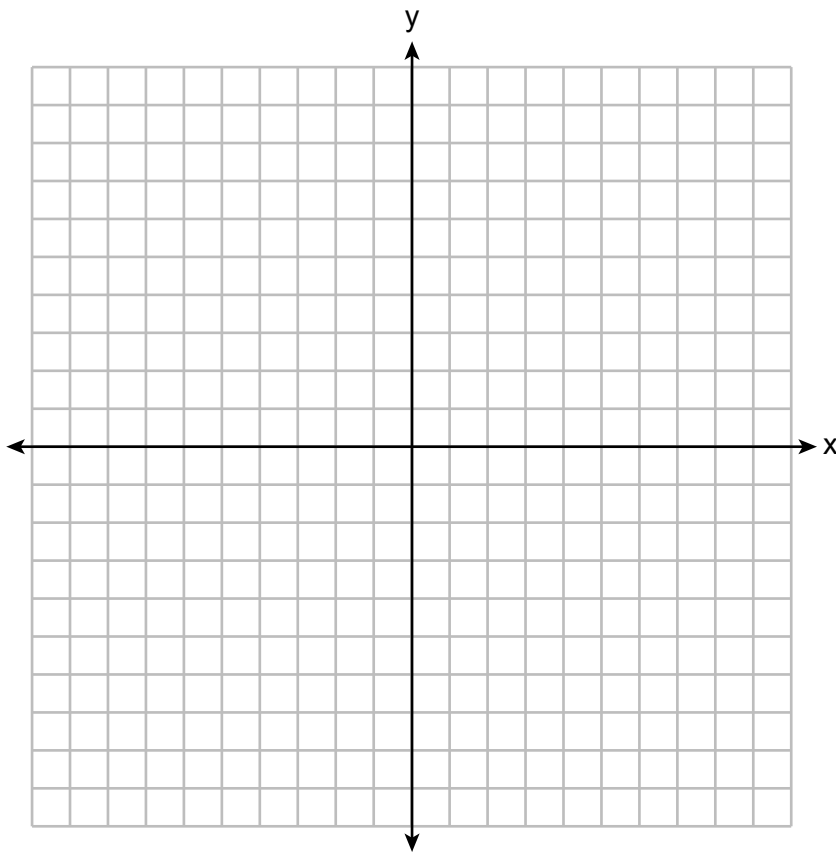





Scrap Graph Paper — this sheet will *not* be scored.

Tear Here

Tear Here

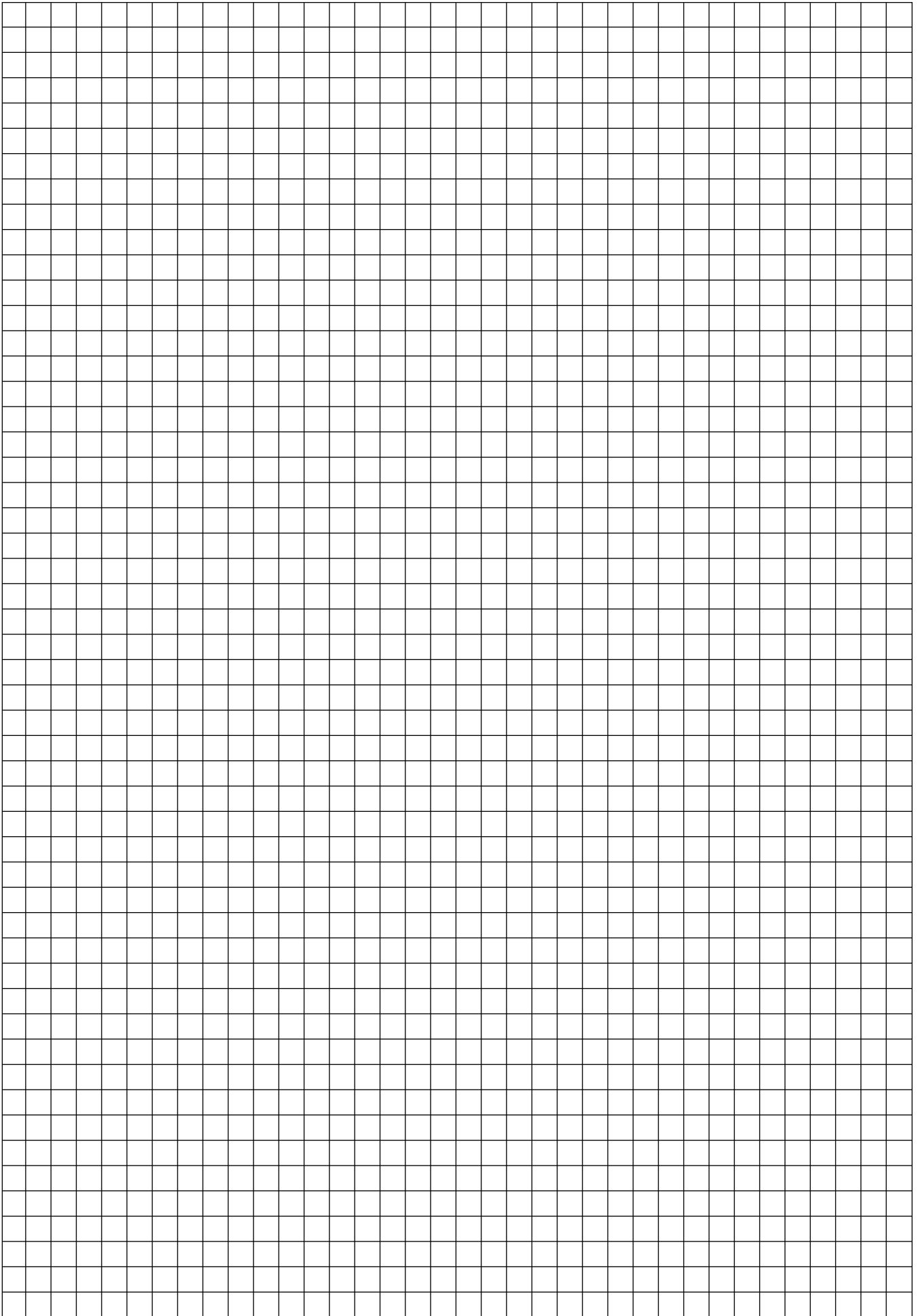

Scrap Graph Paper — this sheet will *not* be scored.

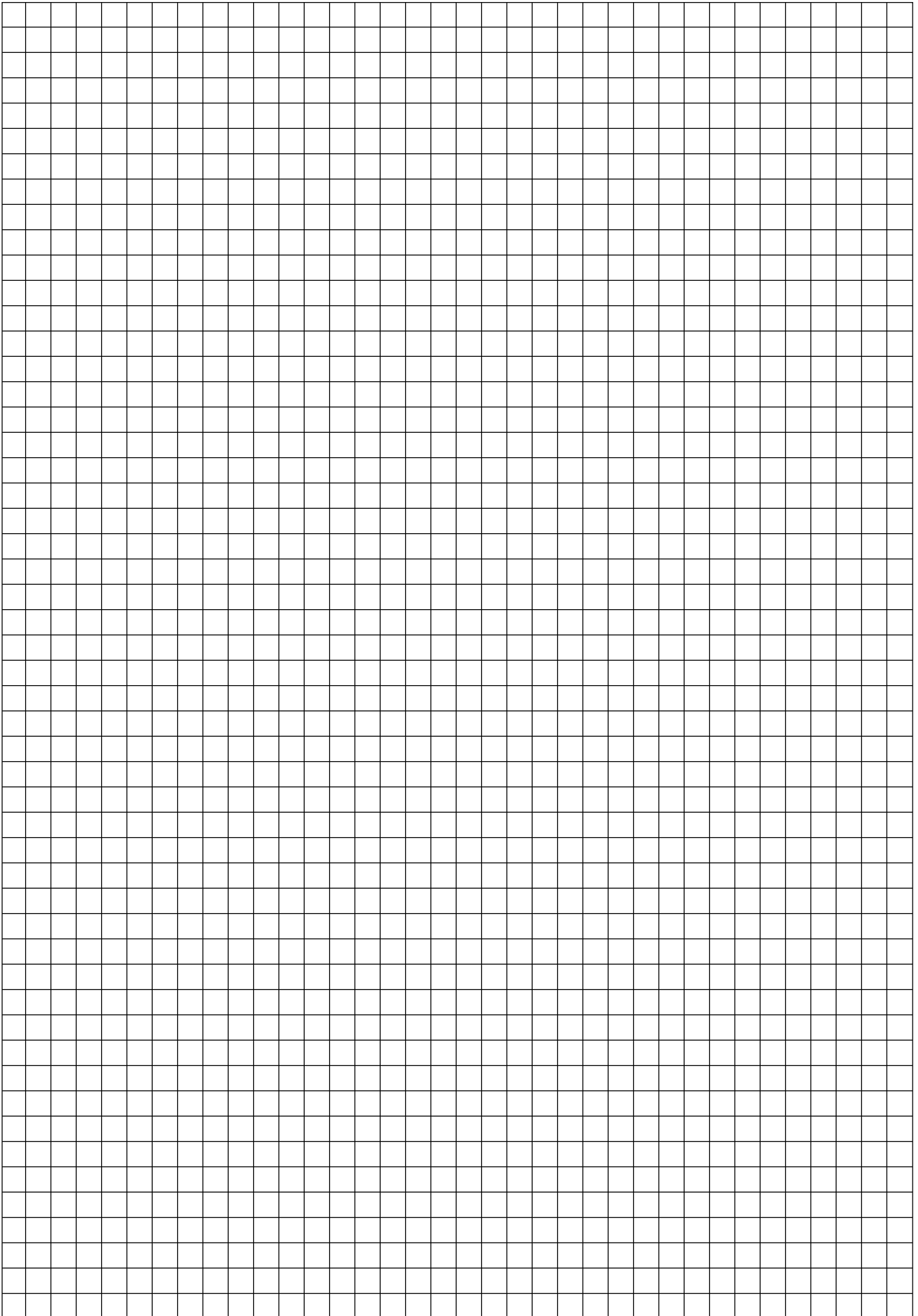

Tear Here

Tear Here

## High School Math Reference Sheet

1 inch = 2.54 centimeters	1 kilometer = 0.62 mile	1 cup = 8 fluid ounces
1 meter = 39.37 inches	1 pound = 16 ounces	1 pint = 2 cups
1 mile = 5280 feet	1 pound = 0.454 kilogram	1 quart = 2 pints
1 mile = 1760 yards	1 kilogram = 2.2 pounds	1 gallon = 4 quarts
1 mile = 1.609 kilometers	1 ton = 2000 pounds	1 gallon = 3.785 liters
		1 liter = 0.264 gallon
		1 liter = 1000 cubic centimeters

Triangle	$A = \frac{1}{2}bh$
Parallelogram	$A = bh$
Circle	$A = \pi r^2$
Circle	$C = \pi d$ or $C = 2\pi r$
General Prisms	$V = Bh$
Cylinder	$V = \pi r^2 h$
Sphere	$V = \frac{4}{3}\pi r^3$
Cone	$V = \frac{1}{3}\pi r^2 h$
Pyramid	$V = \frac{1}{3}Bh$

Pythagorean Theorem	$a^2 + b^2 = c^2$
Quadratic Formula	$x = \frac{-b \pm \sqrt{b^2 - 4ac}}{2a}$
Arithmetic Sequence	$a_n = a_1 + (n - 1)d$
Geometric Sequence	$a_n = a_1 r^{n - 1}$
Geometric Series	$S_n = \frac{a_1 - a_1 r^n}{1 - r}$ where $r \neq 1$
Radians	1 radian = $\frac{180}{\pi}$ degrees
Degrees	1 degree = $\frac{\pi}{180}$ radians
Exponential Growth/Decay	$A = A_0 e^{k(t - t_0)} + B_0$

Tear Here

Tear Here

# GEOMETRY

Tear Here

Tear Here

Printed on Recycled Paper

GEOMETRY